

S9968

**Simplicity**<sup>®</sup>



Designed and printed in USA.



Shop all the pattern brands you love @

**Simplicity**<sup>®</sup>.com

Average

**BAGS AND CHARM**

**Suggested Fabrics:** A,B,C **Contrast 1, D, Linings A,B,C:** Cotton/Cotton Blends. **A also in:** Short Pile Fleece. **C Contrast 1 also in:** Corduroy. **C Contrast 2:** Vinyl. **Interfacing A,C,D, B**  
**Interfacing 1:** ¼" (3mm) one-sided fusible foam stabilizer. **B Interfacing 2:** Lightweight Sew-in.

**Notions:** **A:** Polyfil, one 9" (23cm) zipper. **B:** ½ yds. (1.3m) of ¾" (2cm) woven strap, one 9" (23cm) zipper. **C:** One 12" (30cm) zipper, one 29" (74cm) handbag chain (or any length of your choice) with two swivel hook clasps, one pkg. of ¼" (6mm) double fold bias tape. **D:** ½ yd. (0.5m) of ¼" (3mm) ribbon.

**Bag A:** 4¼" H x 8½" W x 5" D (11cm x 22cm x 13cm)

45"\* - ⅝ yd. (115cm\* - 0.6m)

60"\* - ¾ yd. (150cm\* - 0.3m)

**Lining:** 45"\* - ¾ yd. (115cm\*\* - 0.3m)

**Interfacing:** 20" - ½ yd. (51cm - 0.5m)

**Bag B:** 5¾" H x 9¼" W x 3¾" D (15cm x 24cm x 10cm)

45"\* - ⅝ yd. (115cm\* - 0.8m)

60"\* - ¾ yd. (150cm\* - 0.7m)

**Lining:** 45"\* - ⅞ yd. (115cm\*\* - 0.8m)

**Interfacing 1:** 20" - ¾ yd. (51cm - 0.7m)

**Interfacing 2:** Same yardage as Interfacing 1

**Bag C:** 7½" H x 9" W x 2½" D (19cm x 23cm x 7cm)

45"\* - ¾ yd. (115cm\* - 0.3m)

**Contrast 1 (Bottom, Loops, Top, Bow, Knot):** 45"\* - ¼ yd. (115cm\* - 0.2m)

**Contrast 2 (Patch)** - 7" x 8" (18cm x 20cm) vinyl remnant

**Lining:** 45"\* - ½ yd. (115cm\*\* - 0.5m)

**Interfacing:** 20" - ⅝ yd. (51cm - 0.6m)

**Heart Charm D:** 3" H x 3¾" W (8cm x 10cm)

5" x 8" (13cm x 20cm) remnant in each of fabric and interfacing

\*with nap \*\*without nap



A



B



C



D

# Simplicity® s9968

Thank you for purchasing this Simplicity pattern.  
We made every effort to provide you with a high quality product.

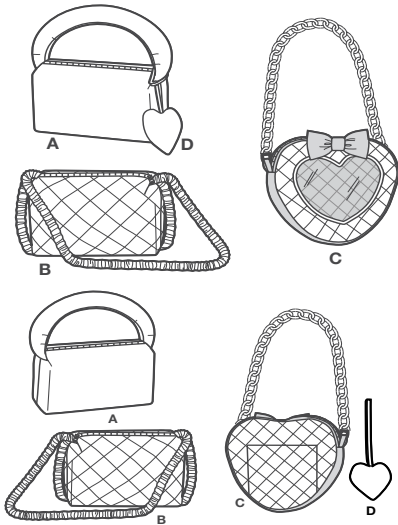

17 PIECES

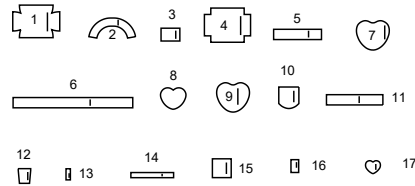

- 1 FRONT AND BACK - A
- 2 HANDLE - A
- 3 INSIDE POCKET - A, B
- 4 FRONT AND BACK - B
- 5 SIDE HANDLE - B
- 6 SHOULDER STRAP - B
- 7 FRONT - C
- 8 PATCH - C
- 9 BACK - C
- 10 POCKET - C
- 11 BOTTOM - C
- 12 INSIDE POCKET - C
- 13 LOOP - C
- 14 TOP - C
- 15 BOW - C
- 16 KNOT - C
- 17 HEART CHARM - D

## Cutting Layouts

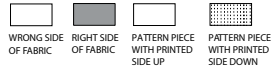

★ SEE SPECIAL CUTTING NOTES

POSITION OF PATTERN PIECES MAY VARY SLIGHTLY ACCORDING TO YOUR PATTERN SIZE

### General Directions For Cutting

**PRE-SHRINK** and iron all fabric.

**FOR DOUBLE THICKNESS** -Fold fabric with **RIGHT** sides together. Pin pattern to **WRONG** side of fabric.

**FOR SINGLE THICKNESS** -Pin pattern to **RIGHT** side of fabric.

★ If layout shows a piece extending past fold, cut out all pieces except piece that extends. Open out fabric to single thickness. Cut extending piece on **RIGHT** side of fabric in position shown.

✱ Mark small arrows along both selvages in dictating direction of nap or design. Fold fabric crosswise with **RIGHT** sides together, and cut along fold. Turn one fabric layer around so arrows on both layers go in the same direction. Place **RIGHT** sides together.

### BAG A

USE PIECES 1 2

45" (115CM)  
WITH NAP  
ALL SIZES

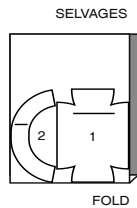

60" (150CM)  
WITH NAP  
ALL SIZES

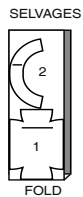

### LINING A

USE PIECES 1 3

45" (115CM)  
WITH NAP  
ALL SIZES

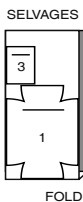

### INTERFACING

USE PIECE 1

20" (51CM)  
ALL SIZES

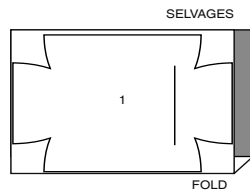

### BAG B

USE PIECES 4 5 6

45" (115CM)  
WITH NAP  
ALL SIZES



60" (150CM)  
WITH NAP  
ALL SIZES



### LINING B

USE PIECES 3 4 5 6

45" (115CM)  
WITH NAP  
ALL SIZES

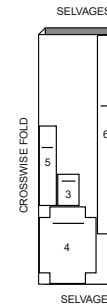

### INTERFACING 1, USE SAME LAYOUT FOR INTERFACING 2

USE PIECE 4

20" (51CM)  
ALL SIZES

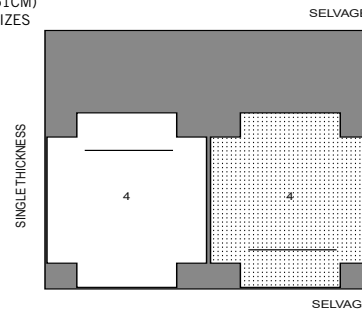

### BAG C

USE PIECES 7 9 10

45" (115CM)  
WITH NAP  
ALL SIZES

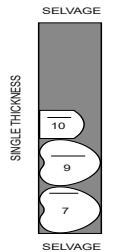

### CONTRAST 1 (BOTTOM, LOOPS, TOP, BOW, KNOT)

USE PIECES 11 13 14 15 16

45" (115CM)  
WITH NAP  
ALL SIZES

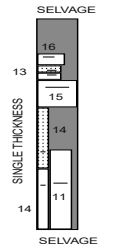

### CONTRAST 2 (PATCH)

CUT ONE OF PIECE 8 FROM FABRIC REMNANT

### LINING C

USE PIECES 7 9 10 11 12 14

45" (115CM)  
WITH NAP  
ALL SIZES

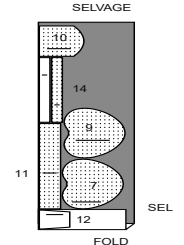

### INTERFACING

USE PIECES 7 9 10 11 14 15

20" (51CM)  
ALL SIZES

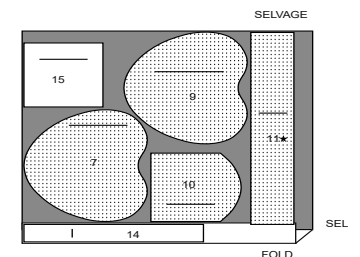

### HEART CHARM D

CUT TWO OF PIECE 17 FROM FABRIC REMNANT AND CUT ONE OF PIECE 17 FROM INTERFACING REMNANT.

## SEWING TUTORIALS



Build your skills viewing short, easy-to-follow videos at [simplicity.com/sewingtutorials](http://simplicity.com/sewingtutorials)

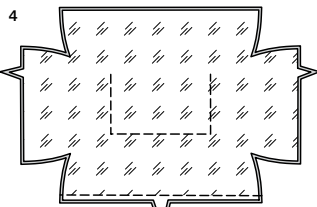
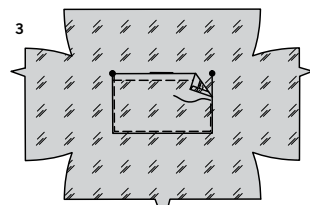
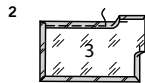
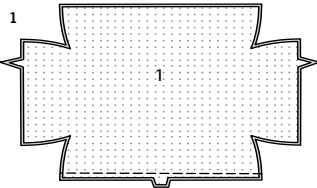
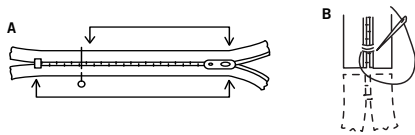

## Sewing Directions

FABRIC KEY RIGHTSIDE WRONGSIDE INTERFACING LINING LINING

Read **General Directions** on page 1 before you begin.

Sewing methods in **BOLD TYPE** are explained below:

**EDGE STITCH** - Stitch close to finished edge or seam.

**FINISH** - Stitch 1/4" (6mm) from raw edge and finish with one of the following: (1) Pink OR (2) Overcast OR (3) Turn in along stitching and stitch close to fold OR (4) Overlock.

**INTERFACING** - Pin interfacing to **WRONG** side of fabric. Fuse interfacing in place following manufacturer's directions.

**SLIPSTITCH** - Slide needle through a folded edge, then pick up a thread of underneath fabric.

**GENERAL DIRECTIONS FOR ADJUSTING ZIPPERS**

**NOTE:** Stitch zipper using an adjustable zipper foot.

**A.** It may be necessary to shorten the zipper as follows:

Close zipper and measure from the tab down along the teeth, making the zipper 1" (2.5cm) shorter than the length of the upper edge of bag.

**B.** With matching buttonhole twist or heavy duty thread, make several overcast stitches across the zipper teeth. Trim away lower end of zipper tape to within 3/8" (1cm) of overcast stitches.

**NOTE:** All seams are 1/4" (6mm) unless otherwise indicated.

**BAG A**

**1.** Apply fusible **INTERFACING** to **FRONT AND BACK (1)** fabric sections. With **RIGHT** sides together, stitch double notched edge of front and back fabric sections.

**2.** Press under 1/2" (1.3cm) on upper edge of **INSIDE POCKET (3)** to **INSIDE**. Press under 1/4" (6mm) on raw edge. Stitch close to inner pressed edge. Press under 1/4" (6mm) on side and lower edges of pocket.

**3.** Pin pockets to **RIGHT** side of front and back lining sections matching large dots, placing pressed edges along placement lines. **EDGE STITCH** lower and side edges of pockets.

**4.** Stitch double notched edge of front and back lining sections.

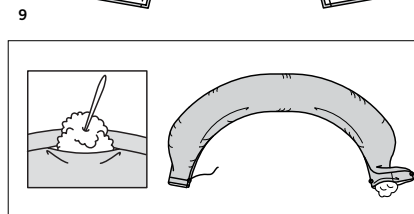
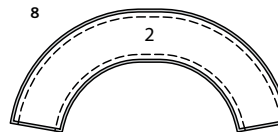
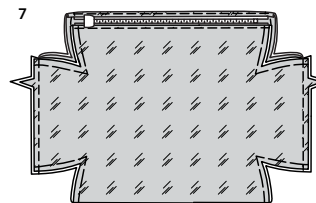
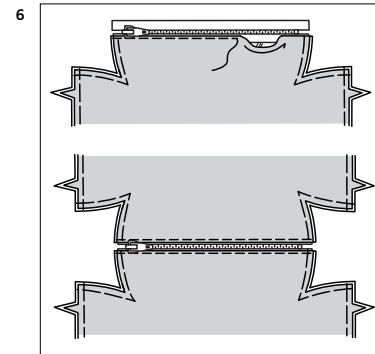
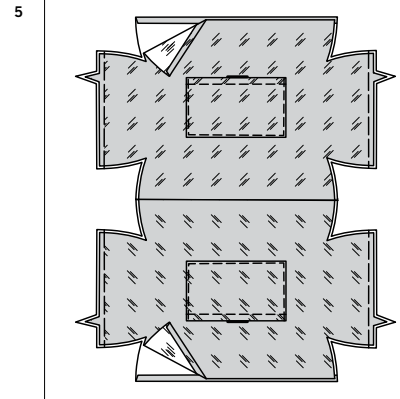

**5.** Press under 1/4" (6mm) on upper edges of front and back fabric and lining sections, as shown. With **WRONG** side together, pin bag to bag lining, having raw edges even. Baste side edges together, as shown.

**6.** Pin closed zipper between pressed edge of front and back fabric and lining sections, placing pressed edges of bag close to zipper teeth with tab end 1/4" (6mm) from one edge and zipper teeth exposed 3/8" (1cm) between pressed edges. Using an adjustable zipper foot, **EDGE STITCH** pressed edge of bag being sure to catch in bag lining. Open zipper and stitch other side of the zipper to remaining front and back fabric and lining sections in the same manner as above. Baste raw edges together.

**7.** With **RIGHT** sides together, stitch front and back together at sides, matching notches.

**8.** With **RIGHT** sides together, pin handle (2) sections together, having raw edges even. Stitch side edges, leaving ends open.

**9.** Turn handle **RIGHT** side out. Press. Lightly Stuff. Fold ends along fold line, bringing small dots together. Baste. **TIP** - Pull fiberfill apart and fluff it before you use it. Break apart the lumps and thick spots. This will help to create a smoother looking project. Use small pieces and pack into place using the end of a crochet hook or chop-stick.

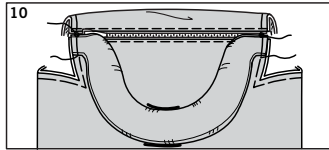

- 10.** On **OUTSIDE**, pin strap to upper edge of bag, placing small dot at center of zipper. Baste.

11

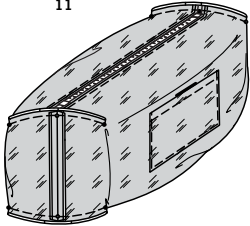

- 11.** To form dart seams at upper edge, with **RIGHT** sides together, bring side and zipper edge together, matching small dots and having raw edges even. Stitch across corners. Form seams at lower edge, by bringing side and lower seams together in same manner. Stitch across corners. **FINISH** raw edges of seams if you prefer.

## BAG B

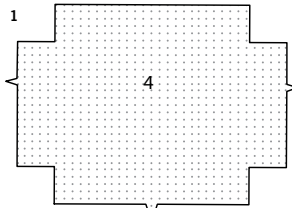

- 1.** Apply fusible **INTERFACING** to front and back (4) fabric sections.

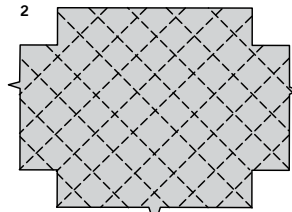

- 2.** Quilt front and back sections as follows: Using marked stitching lines as a guide, draw additional stitching lines spacing 1-3/8" (3.5cm) apart, as shown. on **OUTSIDE**, stitch along stitching lines through all thicknesses.

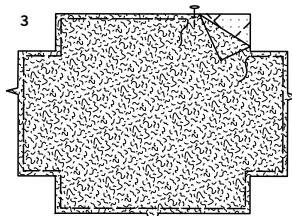

- 3.** Pin Lightweight Sew-In **INTERFACING** to front and back sections, (over fusible interfacing) having raw edges even. Baste 1/4" (6mm) from raw edge.

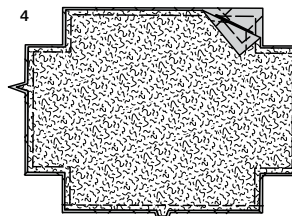

- 4.** With **RIGHT** sides together, stitch double notched edge of front and back fabric sections.

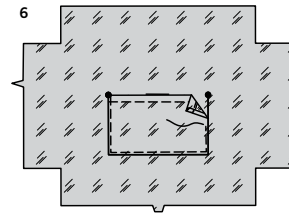
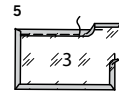

- 5.** Press under 1/2" (1.3cm) on upper edge of **INSIDE POCKET** (3) to **INSIDE**. Press under 1/4" (6mm) on raw edge. Stitch close to inner pressed edge. Press under 1/4" (6mm) on side and lower edges of pocket.
- 6.** Pin pockets to **RIGHT** side of front and back lining sections matching large dots, placing pressed edges along placement lines. **EDGESTITCH** lower and side edges of pockets.

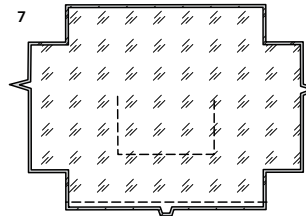

- 7.** Stitch double notched edge of front and back lining sections.

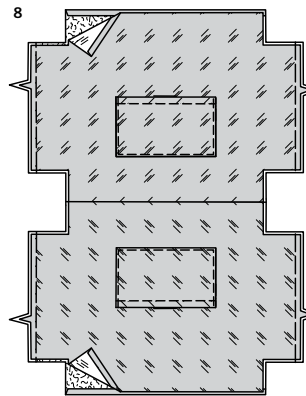

- 8.** Press under 1/4" (6mm) on upper edges of bag and bag lining sections, as shown. With **WRONG** side together, pin bag to bag lining, having raw edges even. Baste side edges together, as shown.

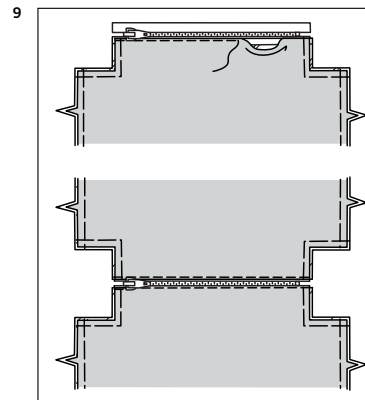

- 9.** Pin closed zipper between pressed edge of front and back fabric and lining sections, placing pressed edges of bag close to zipper teeth with tab end 1/4" (6mm) from one edge and zipper teeth exposed 3/8" (1cm) between pressed edges. Using an adjustable zipper foot, **EDGESTITCH** pressed edge of bag being sure to catch in bag lining. Open zipper and stitch other side of the zipper to remaining front and back fabric and lining sections in the same manner. Baste raw edges together.

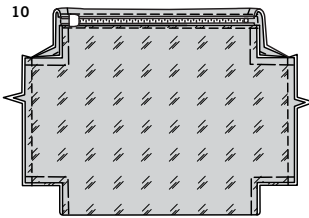

**10.** With RIGHT sides together, stitch front and back together at sides, matching notches.

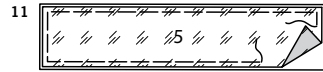

**11.** Construct two side handles as follows:  
Pin RIGHT side of side handle (5) lining section to WRONG side of fabric section, having raw edges even. Baste along outer edge.



**12.** Fold handle in half lengthwise, with RIGHT sides together. Stitch long edge, leaving ends with small dots open.



**13.** Turn strap RIGHT side out, bringing seam to center. Press.

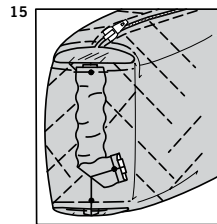
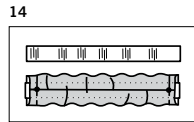

**14.** Cut two pieces of woven strap, each measuring 7-1/2" (19.05cm) long.  
Insert one end of strap through side opening in handle, bunching up fabric to bring raw edges of strap even with fabric. Baste raw edges together.

**15.** With seam facing down, on OUTSIDE, pin handles to each side edge of bag, matching small dots at center. Baste in place.

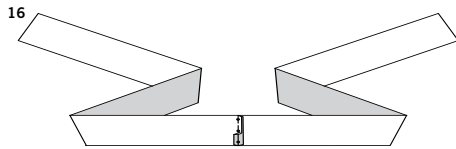

**16.** For shoulder strap, with RIGHT sides together, stitch two shoulder strap (6) sections together, at one end matching small dots.

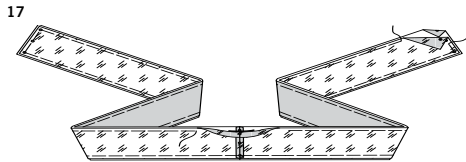

**17.** Stitch shoulder strap lining sections together matching small dots.  
Pin RIGHT side of shoulder strap lining section to WRONG side of fabric section, having raw edges even. Baste along outer edge.

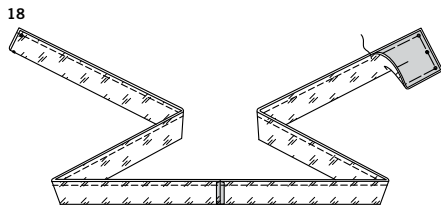

**18.** Fold strap in half lengthwise, with RIGHT sides together. Stitch long edge, leaving ends with small dots open.

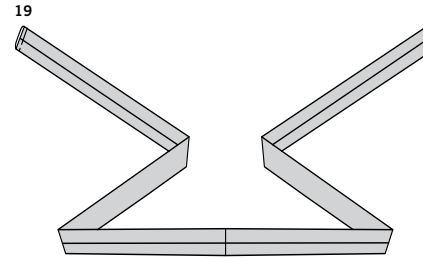

**19.** Turn strap RIGHT side out, bringing seam to center, press.

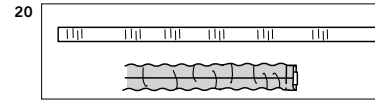

**20.** Cut a piece of woven strap, measuring 33" (84cm) long.  
Insert one end of strap through side opening in handle, bunching up fabric to bring raw edges of strap even with fabric. Baste raw edges together.

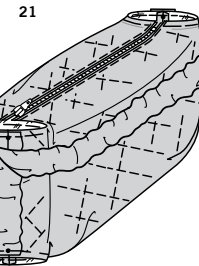

**21.** With seam facing up, on OUTSIDE, pin shoulder strap to upper edge of bag at each side, matching small dots at center of zipper. Baste in place.

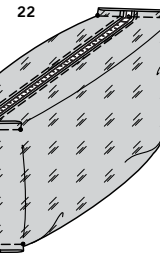

**22.** To form dart seams at upper edge, with RIGHT sides together, bring side and zipper edge together, matching small dots and having raw edges even. Stitch across corners.  
Form seams at lower edge, by bringing side and lower seams together in same manner. Stitch across corners. Trim seams.  
**FINISH** raw edges of seams if you prefer.

## BAG C

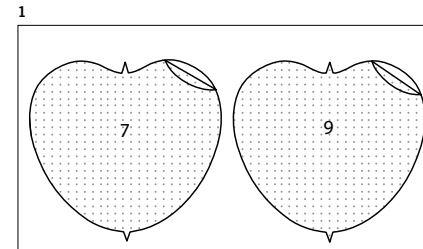

**1.** Apply fusible **INTERFACING** to FRONT (7) and BACK (9) fabric sections.

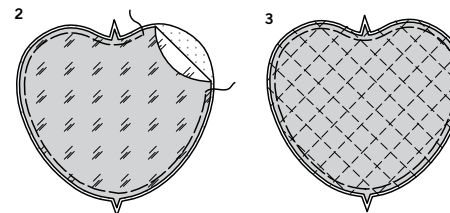

**2.** With WRONG sides together, pin lining to front and back fabric sections, having raw edges even. Baste.

**3.** Quilt front and back sections as follows:  
Using marked stitching lines as a guide, draw additional stitching lines spacing 1" (2.5cm) apart, as shown.  
On OUTSIDE, stitch along stitching lines through all thicknesses.

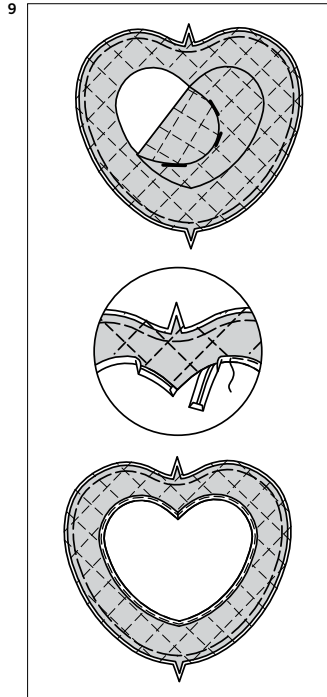
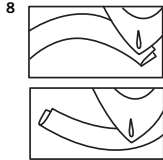
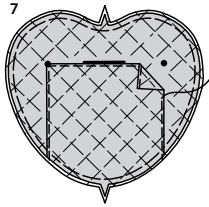
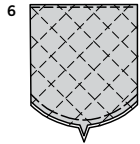
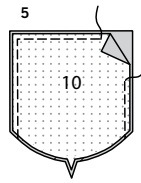
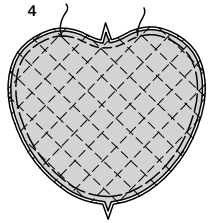

4. Machine-stitch 1/4"(6mm) from upper edge of front and back, along inner curve.

5. Fuse **INTERFACING** to pocket (10) fabric section. With **RIGHT** sides together, pin pocket lining to pocket, having raw edges even. Stitch along outer edge, leaving notched edge free.

6. Turn pocket **RIGHT** side out, press. **EDGESTITCH** upper edge of pocket. Baste raw edges together. On **OUTSIDE**, quilt pocket in same manner as front and back, spacing stitching lines 1"(2.5cm) apart, as shown. Stitching through all thicknesses.

7. On **OUTSIDE**, pin pocket to back matching large dots and notches, placing finished edges along placement lines. **EDGESTITCH** side edges of pocket.

8. **NOTE:** When binding is applied to a curved surface, first, preshape it with a steam iron. For an inward curve, stretch the double edges and press; for an outward curve, stretch the fold edge and press.

9. Cut front section, along cut out lines.

To finish inner raw edge of front, slip the raw edge between the folds of the bias tape placing the raw edge against the center crease and the wider folded edge of the tape on the **INSIDE**. Turn under ends to meet at center. Stitch the tape in place from the **OUTSIDE**, being sure to catch in the folded edge on the **INSIDE**.

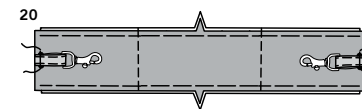
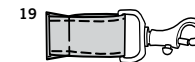
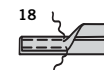
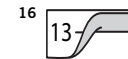
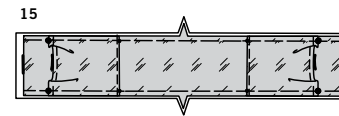
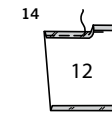
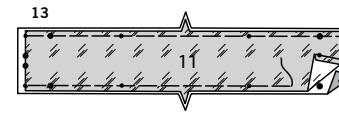
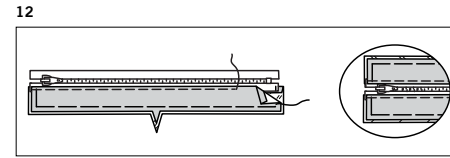
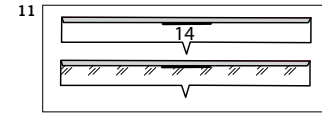
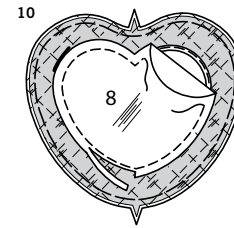

10. On **INSIDE**, pin **PATCH** (8) to front, centering over front opening edges, as shown. **EDGESTITCH** patch in place, over previous bias tape stitching. Trim away edges of patch if you prefer.

11. Press under 1/4" (6mm) on unnotched edge of top (14) fabric and lining sections.

12. Pin closed zipper between pressed edge of top and top lining, placing pressed edges of bag close to zipper teeth with tab end 1/4" (6mm) from one edge and zipper teeth exposed 3/8" (1cm) between pressed edges. Using an adjustable zipper foot, **EDGESTITCH** pressed edge of top being sure to catch in lining. Open zipper and stitch other side of the zipper to remaining top and top lining sections in the same manner. Baste raw edges together.

13. Press under 1/4"(6mm) seam allowance on ends of bottom (11) lining sections. With **WRONG** sides together pin bottom lining to bottom having raw edges even, matching markings. Baste raw edges together.

14. Press under 1/2"(1.3cm) on upper edge of **INSIDE POCKET** (12) to **INSIDE**. Press under 1/4"(6mm) on raw edge. Stitch close to inner pressed edge. Press under 1/4"(6mm) on lower edge.

15. On **INSIDE**, pin pockets to each side of bottom matching large and small dots. **EDGESTITCH** lower edge of pockets. Baste raw edges together.

16. Fold each loop (13) section in half, lengthwise with **WRONG** sides together. Press, setting in a crease.

17. Open out long edges of loop and turn them to **WRONG** side so that they meet at the crease. Press.

18. Fold carrier in half lengthwise, bringing pressed edges together. Stitch close to both long edges.

19. Fold loops in half, around end of swivel clip. Baste raw edges together.

20. On **OUTSIDE**, pin loops to each side of bottom, centering ends between large dots. Baste.

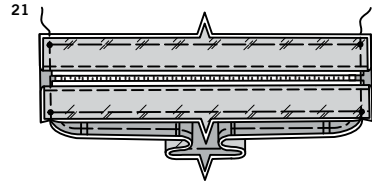

**21.** With RIGHT sides together, pin top to each side of bottom matching large and small dots. Stitch, keeping pressed edge of bottom lining free.

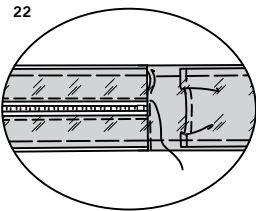

**22.** Pin pressed edge of bottom lining over seam. **EDGESTITCH** in place.

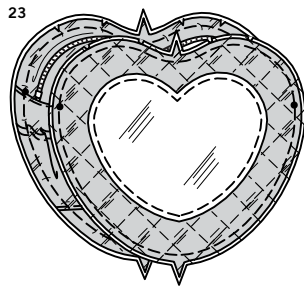

**23.** With RIGHT sides together, pin top and bottom to outer edge of front and back sections, having raw edges even, matching notches and small dots. Making scant 1/4" (6mm) clips to basting, along curved edge if necessary. Baste. Stitch. **FINISH** raw edges of seams if you prefer.

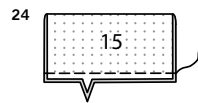

**24.** Construct bow as follows:  
Fuse **INTERFACING** to BOW (15). Fold bow in half, lengthwise, with RIGHT sides together. Stitch notched edge in 1/4" (6mm) seam.

**25.** Turn bow RIGHT side out, bringing seam to center; press. Bring ends to **UNDERSIDE**, having ends extend 1/4" (6mm) beyond center. Stitch along center of bow.

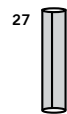
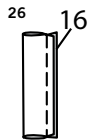

**26.** Fold KNOT (16) in half, lengthwise, with RIGHT sides together. Stitch long edge in 1/4" (6mm) seam.

**27.** Turn knot RIGHT side out, bringing seam to center on **UNDERSIDE**; press.

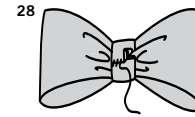

**28.** Crush bow at center and place knot around center of bow, turning under and lapping one end on **UNDERSIDE**. **SLIPSTITCH** ends securely catching in **UNDERSIDE** of bow.

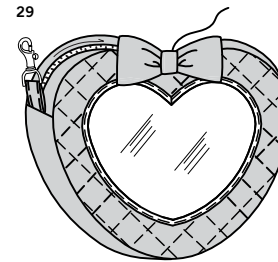

**29.** Hand-sew bow to center front of purse, as shown. Clip ends of swivel clips to ends of handbag chain, as shown on front of envelope.

## HEART CHARM D

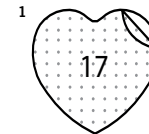

**1.** Fuse **INTERFACING** to one heart charm (17) section.

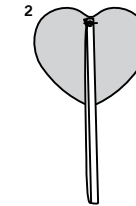

**2.** Cut a piece of ribbon measuring 14" (36cm) long. Fold ribbon in half forming loop. On **OUTSIDE**, pin ribbon to upper edge of charm, centering ends over large dot. Baste. **TIP:** Pin ribbon out of the way when stitching remaining seams.



**3.** With RIGHT sides together, pin charm sections together. Stitch, leaving an opening, large enough for turning.

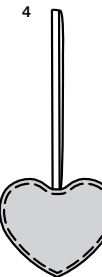

**4.** Turn charm RIGHT side out. Press. Pressing under opening edges. **EDGESTITCH** outer edge of charm, closing opening.



# Congrats!

You've completed your sewing adventure

---

**SHARE  
YOUR** LOOK



Post your pattern and tag us  
**@simplicity\_creative\_group** and **#simplicitypatterns**  
for a chance to be featured on our social media.

Look for more PDF patterns at [simplicity.com](https://www.simplicity.com)

Have a question or need help with your sewing project call us at  
1-888-588-2700



Simplicity ©2024 a division of IG Design Group Americas Inc. • Atlanta, GA 30342 USA [www.thedesigngroup.com](http://www.thedesigngroup.com) • All Rights Reserved. [www.simplicity.com](http://www.simplicity.com) • Made in the U.S.A. Fabriqué aux États-Unis.

To be used for individual private home use only and not for commercial or manufacturing purposes. • A usage privé seulement et non à des fins commerciales ou de production en série. • Para uso privado solamente, no se puede utilizar con propósitos de comercialización o de producción en serie.