

S9937

Simplicity[®]



Designed and printed in USA.

Shop all the pattern brands you love @

Simplicity[®].com

Average



HAT, TOTE BAG AND ZIPPER CASES

Suggested Fabrics: A,C,D,E,F,G,H,I,J,K: Contrasts A, Linings: Cotton/Cotton Blends. B: Canvas, Denim, Twill. A,B Interfacing 1: Heavy craft weight sew-in. A Interfacing 2: Lightweight Fusible. B Interfacing 2: Headliner Fabric. B Interfacing 3 and Interfacing F,G,H,I,J,K: Fusible Fleece. Interfacing C,D,E: Medium weight Fusible.
Notions: B: One 12 x 18" (30cm x 46cm) plastic canvas or cardboard. C,D,E,F,G,H,I,J,K: Zipper: 6" (15cm - cut to fit) for C,D,E, 14" (36cm - cut to fit) for F,G,H, 12" (30cm - cut to fit) for I,J,K. Also for C,D,E: 5" (13cm) length of ¼" (6mm) ribbon. Also for F,G,H,I,J,K: 8" (21cm) length of ¼" (6mm) ribbon.

Hat A - available in S-21" (53cm), M-22" (56cm), L-23" (58cm)

45** - ¾ yd. (115cm* - 0.6m)
Contrast (Brim, Crown, Top, Band): 45** - ¾ yd. (115cm* - 0.6m)
Interfacing 1: 20" - ¾ yd. (51cm* - 0.7m)
Interfacing 2: 20" - ¾ yd. (51cm - 0.8m)

Tote B - 15" H x 17" W x 7" D (38cm x 43cm x 18cm)

45** - 1¼ yds. (115cm* - 1.1m)
Contrast (Straps): 45** - 1¼ yds. (115cm* - 1.6m)
Patch 1: 6" x 6" (15cm x 15cm) in two different fabrics
Patch 2: 4" x 6" (10cm x 15cm) in two different fabrics
Patch 3: 4" x 6" (10cm x 15cm) in two different fabrics
Patch 4: 4" x 6" (10cm x 15cm) in six different fabrics
Lining: 45*** - 1¼ yds. (115cm** - 1.1m)
Interfacing 1: 20" - 1¼ yds. (51cm* - 1.6m)
Interfacing 2: 54" - ¾ yd. (140cm - 0.7m)
Interfacing 3: 22" - ¾ yd. (56cm - 0.0m)

Zipper Case C (Small) - 3½" H x 3½" W x 3½" D (9cm x 9cm x 9cm)

Fabric: 5" x 5" (13cm x 13cm) fabric remnant
Contrast: 5" x 5" (13cm x 13cm) fabric remnant
Lining: 5" x 10" (13cm x 26cm) remnant
Interfacing: 5" x 10" (13cm x 26cm) remnant

Zipper Case D (Medium) - 4½" H x 4½" W x 4½" D (11cm x 11cm x 11cm)

Fabric: 6" x 6" (15cm x 15cm) fabric remnant
Contrast: 6" x 6" (15cm x 15cm) fabric remnant
Lining: 6" x 12" (15cm x 31cm) remnant
Interfacing: 6" x 12" (15cm x 31cm) remnant

Zipper Case E (Large) - 5½" H x 5½" W x 5½" D (14cm x 14cm x 14cm)

Fabric: 7" x 7" (18cm x 18cm) fabric remnant
Contrast: 7" x 7" (18cm x 18cm) fabric remnant
Lining: 7" x 14" (18cm x 36cm) remnant
Interfacing: 7" x 14" (18cm x 36cm) remnant

Zipper Case F (Small) - 3½" H x 3½" W x 1¼" D (9cm x 9cm x 4cm)

Fabric: 7" x 9" (18cm x 23cm) fabric remnant
Contrast: 7" x 9" (18cm x 23cm) fabric remnant
Lining: 9" x 12" (23cm x 31cm) remnant
Interfacing: 9" x 12" (23cm x 31cm) remnant

Zipper Case G (Medium) - 5" H x 5" W x 2½" D (13cm x 13cm x 6cm)

Fabric: 10" x 12" (26cm x 31cm) fabric remnant
Contrast: 10" x 12" (26cm x 31cm) fabric remnant
Lining: 12" x 17" (31cm x 43cm) remnant
Interfacing: 12" x 17" (31cm x 43cm) remnant

Zipper Case H (Large) - 3½" H x 8" W x 3½" D (9cm x 20cm x 9cm)

Fabric: 9" x 14" (23cm x 36cm) fabric remnant
Contrast: 9" x 14" (23cm x 36cm) fabric remnant
Lining: 14" x 18" (36cm x 46cm) remnant
Interfacing: 14" x 18" (36cm x 46cm) remnant

Zipper Case I (Small) - 4" H x 4" W x 1¼" D (10cm x 10cm x 4cm)

Fabric: 8" x 10" (21cm x 26cm) fabric remnant
Contrast 1 (Back): 7" x 9" (18cm x 23cm) fabric remnant
Contrast 2 (Gusset): 2" x 10" (5cm x 26cm) fabric remnant
Lining: 10" x 13" (26cm x 33cm) remnant
Interfacing: 10" x 13" (26cm x 33cm) remnant

Zipper Case J (Medium) - 5" H x 5" W x 2¼" D (13cm x 13cm x 6cm)

Fabric: 10" x 11" (26cm x 28cm) fabric remnant
Contrast 1 (Back): 8" x 11" (21cm x 28cm) fabric remnant
Contrast 2 (Gusset): 3" x 11" (8cm x 28cm) fabric remnant
Lining: 11" x 16" (28cm x 41cm) remnant
Interfacing: 11" x 16" (28cm x 41cm) remnant

Zipper Case K (Large) - 6" H x 6" W x 2½" D (15cm x 15cm x 6cm)

Fabric: 11" x 11" (28cm x 28cm) fabric remnant
Contrast 1 (Back): 9" x 11" (23cm x 28cm) fabric remnant
Contrast 2 (Gusset): 3" x 11" (8cm x 28cm) fabric remnant
Lining: 11" x 18" (28cm x 46cm) remnant
Interfacing: 11" x 18" (28cm x 46cm) remnant

*with nap **without nap

Simplicity® S9937

Thank you for purchasing this Simplicity pattern.
We made every effort to provide you with a high quality product.

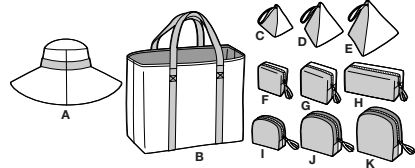
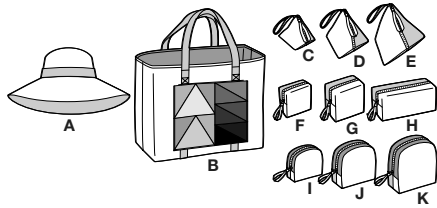

27 PIECES

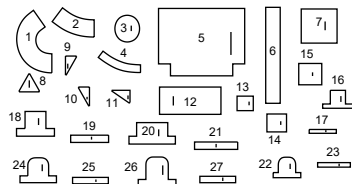

- 1 BRIM - A
- 2 CROWN - A
- 3 TOP - A
- 4 BAND - A
- 5 FRONT AND BACK - B
- 6 STRAP - B
- 7 POCKET LINING - B
- 8 PATCH 1 - B
- 9 PATCH 2 - B
- 10 PATCH 3 - B
- 11 PATCH 4 - B
- 12 BASE - B
- 13 CASE - C
- 14 CASE - D
- 15 CASE - E
- 16 CASE - F
- 17 GUSSET - F
- 18 CASE - G
- 19 GUSSET - G
- 20 CASE - H
- 21 GUSSET - H
- 22 CASE - I
- 23 GUSSET - I
- 24 CASE - J
- 25 GUSSET - J
- 26 CASE - K
- 27 GUSSET - K

Cutting Layouts

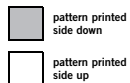

POSITION OF PATTERN PIECES MAY VARY SLIGHTLY ACCORDING TO YOUR PATTERN SIZE

General Directions For Cutting

PRE-SHRINK and iron all fabric.

FOR DOUBLE THICKNESS -Fold fabric with **RIGHT** sides together. Pin pattern to **WRONG** side of fabric.

FOR SINGLE THICKNESS -Pin pattern to **RIGHT** side of fabric.

★ If layout shows a piece extending past fold, cut out all pieces except piece that extends. Open out fabric to single thickness. Cut extending piece on **RIGHT** side of fabric in position shown.

✱ Mark small arrows along both selvages in indicating direction of nap or design. Fold fabric crosswise with **RIGHT** sides together, and cut along fold. Turn one fabric layer around so arrows on both layers go in the same direction. Place **RIGHT** sides together.

HAT A PIECES 1 2 3

45" (115CM)
WITH NAP
SIZES S M

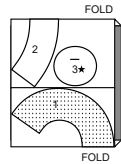

45" (115CM)
WITH NAP
SIZE L

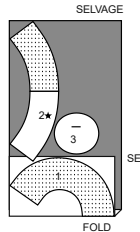

CONTRAST (BRIM, CROWN, TOP, BAND) PIECES 1 2 3 4

45" (115CM)
WITH NAP
SIZES S M

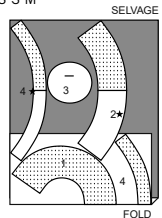

45" (115CM)
WITH NAP
SIZE L

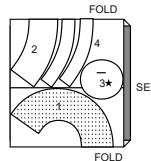

INTERFACING 1 PIECE 1

20" (51CM)
ALL SIZES

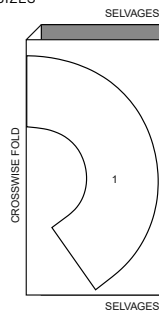

INTERFACING 2 PIECES 2 3

20" (51CM)
ALL SIZES

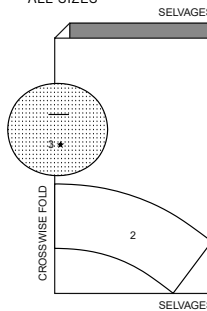

TOTE B PIECE 5

45" (115CM)
WITH NAP

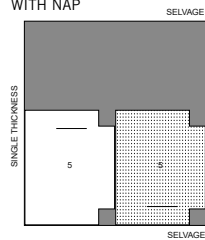

CONTRAST (STRAPS) PIECE 6

45" (115CM)
WITH NAP

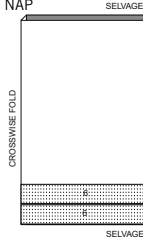

PATCH 1

CUT ONE OF PIECE 8 EACH OF TWO DIFFERENT FABRIC REMNANTS

PATCH 2

CUT ONE OF PIECE 9 EACH OF TWO DIFFERENT FABRIC REMNANTS

PATCH 3

CUT ONE OF PIECE 10 EACH OF TWO DIFFERENT FABRIC REMNANTS

PATCH 4

CUT ONE OF PIECE 11 EACH OF SIX DIFFERENT FABRIC REMNANTS

LINING

PIECES 5 7 12

45" (115CM)
WITHOUT NAP

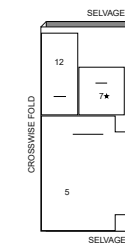

INTERFACING 1

PIECE 6

20" (51CM)

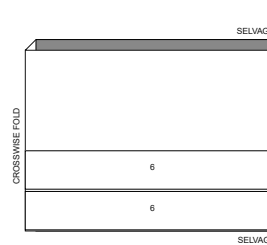

INTERFACING 2

PIECE 5

54" (140CM)

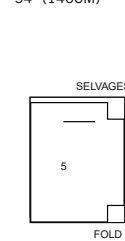

INTERFACING 3

PIECE 7

22" (56CM)



ZIPPER CASE C

CUT ONE OF PIECE 13 EACH OF FABRIC AND CONTRAST REMNANTS

LINING/INTERFACING

CUT TWO OF PIECE 13 EACH OF LINING AND INTERFACING REMNANTS

ZIPPER CASE D

CUT ONE OF PIECE 14 EACH OF FABRIC AND CONTRAST REMNANTS

LINING/INTERFACING

CUT TWO OF PIECE 14 EACH OF LINING AND INTERFACING REMNANTS

ZIPPER CASE E

CUT ONE OF PIECE 15 EACH OF FABRIC AND CONTRAST REMNANTS

LINING/INTERFACING

CUT TWO OF PIECE 15 EACH OF LINING AND INTERFACING REMNANTS

ZIPPER CASE F

CUT TWO OF PIECES 16 17 EACH OF FABRIC AND CONTRAST REMNANTS

LINING/INTERFACING

CUT TWO OF PIECES 16 17 EACH OF LINING AND INTERFACING REMNANTS

ZIPPER CASE G

CUT ONE OF PIECES 18 19 EACH OF FABRIC AND CONTRAST REMNANTS

LINING/INTERFACING

CUT TWO OF PIECES 18 19 EACH OF LINING AND INTERFACING REMNANTS

ZIPPER CASE H

CUT ONE OF PIECES 20 21 EACH OF FABRIC AND CONTRAST REMNANTS

LINING/INTERFACING

CUT TWO OF PIECES 20 21 EACH OF LINING AND INTERFACING REMNANTS

ZIPPER CASE I

CUT ONE OF PIECES 22 23 OF FABRIC REMNANT

CONTRAST 1 (BACK)

CUT ONE OF PIECE 22 OF FABRIC REMNANT

CONTRAST 2 (GUSSET)

CUT ONE OF PIECE 23 OF FABRIC REMNANT

LINING/INTERFACING

CUT TWO OF PIECES 22 23 EACH OF LINING AND INTERFACING REMNANTS

ZIPPER CASE J

CUT ONE OF PIECES 24 25 OF FABRIC REMNANT

CONTRAST 1

CUT ONE OF PIECE 24 OF FABRIC REMNANT

CONTRAST 2

CUT ONE OF PIECE 25 OF FABRIC REMNANT

LINING/INTERFACING

CUT TWO OF PIECES 24 25 EACH OF LINING AND INTERFACING REMNANTS

ZIPPER CASE K

CUT ONE OF PIECES 26 27 OF FABRIC REMNANT

CONTRAST 1

CUT ONE OF PIECE 26 OF FABRIC REMNANT

CONTRAST 2

CUT ONE OF PIECE 27 OF FABRIC REMNANT

LINING/INTERFACING

CUT TWO OF PIECES 26 27 EACH OF LINING AND INTERFACING REMNANTS

SEWING TUTORIALS



Build your skills viewing short, easy-to-follow videos at simplicity.com/sewingtutorials

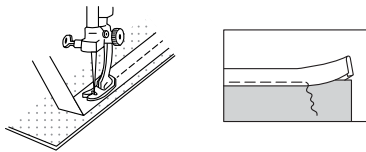
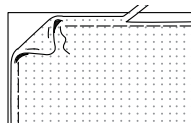

CURVES:

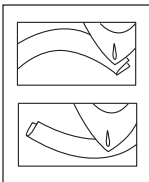

ENDS:

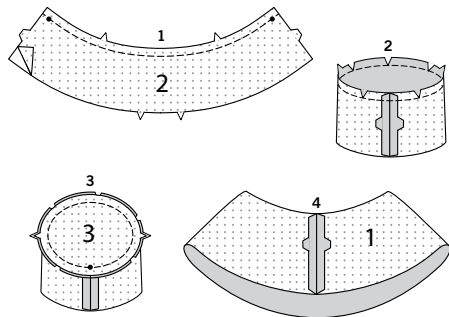
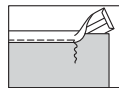

Sewing Directions

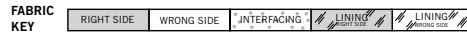

Read **General Directions** on page 1 before you begin.

Sewing methods in **BOLD TYPE** have Sewing Tutorial Video available. Scan QR CODE to watch videos:

EDGE STITCH - Stitch close to finished edge or seam.

INTERFACING - Pin interfacing to **WRONG** side of fabric. Fuse interfacing in place following manufacturer's directions.

SLIPSTITCH - Slide needle through a folded edge, then pick up a thread of underneath fabric.

TOPSTITCH - On outside, stitch 1/4" (6mm) from edge, seam or previous stitching, using presser foot as guide, or stitch where indicated in instructions.

GENERAL DIRECTIONS FOR HEAVY WEIGHT AND HEADLINER INTERFACING

Pin Heavy craft weight interfacing OR Headliner fabric to **WRONG** side of project section, as described in sewing directions. Machine-baste interfacing in place along seam lines. Trim interfacing close to basting.

NOTE: Trimming will not be shown in further illustrations.

TIP: To prevent machine foot from getting caught in the padding, use strips of bond paper between padding and presser foot, then tear them away.

GENERAL DIRECTIONS FOR BIAS TAPE

To finish edge of (item), slip the (item) between the folds of the bias tape placing the raw edge against the center crease and the wider folded edge of the tape on the **INSIDE** of the (item). Stitch the tape in place from the **OUTSIDE**, being sure to catch in the folded edge on the **INSIDE**.

CURVES:

If binding is applied to a curved surface, first, preshape it with a steam iron.

For an inward curve, stretch the double edges and press; for an outward curve, stretch the fold edge and press.

ENDS:

Turn tape ends under to finish an edge or enclose at the seam when possible.

PATTERN PIECES WILL BE IDENTIFIED BY NUMBERS THE FIRST TIME THEY ARE USED.

STITCH SEAMS WITH RIGHT SIDES TOGETHER UNLESS OTHERWISE STATED.

HAT A

NOTE: All seams are 5/8" (1.5cm) unless otherwise indicated.

- Fuse **INTERFACING** to wrong side of crown (2). Machine-stitch 1/2" (1.3cm) from upper edge of crown, with small dots.
- Stitch center back seam of crown. Press seam open. Clip upper edge of crown to stitching.
- Fuse **INTERFACING** to wrong side of top (3). With **RIGHT** sides together, pin top to upper edge of crown, matching centers and small dot, having raw edges even. Stitch seam. Trim seam.
- Apply heavy weight interfacing to one brim (1) section. See **GENERAL DIRECTIONS FOR HEAVY WEIGHT INTERFACING**. Stitch center back seam of each brim fabric and contrast sections. Press seam open.

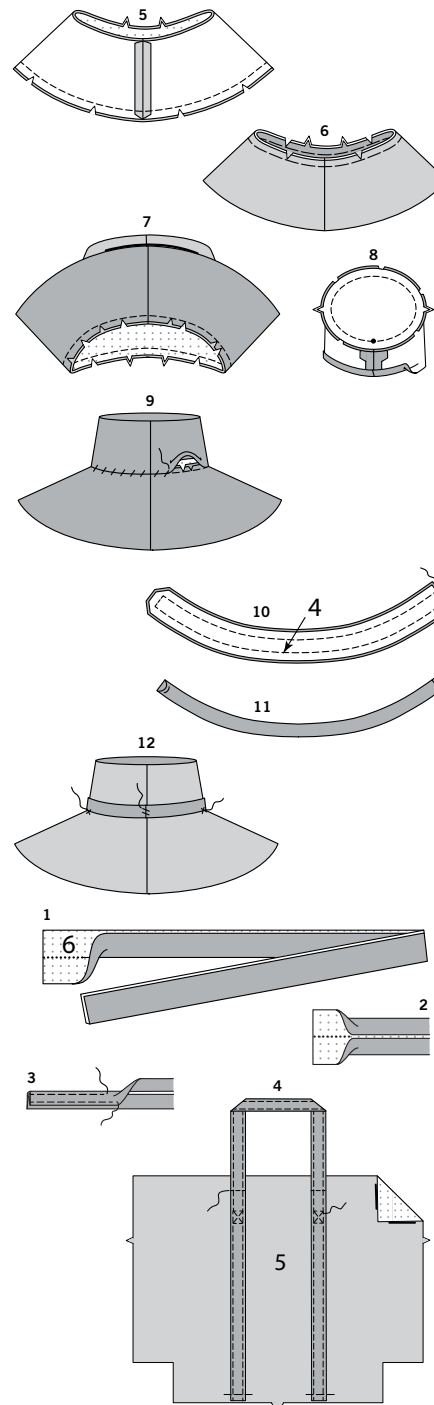

- With **RIGHT** sides together, pin the two brim sections together, matching centers and seams, having raw edges even. Stitch along unnotched edge. Trim seam; clip curves.
- Turn brim **RIGHT** side out; press. Machine-baste raw edges together 1/2" (1.3cm) from raw edge. Clip notched edge of brim to machine-basting.
- On **OUTSIDE**, pin brim to crown, matching centers and notches. Stitch along seam line. Trim.
- Prepare facing same as for crown and top, omitting interfacing. Press under seam allowance on lower edge of hat facing.
- On **INSIDE**, pin facing to hat matching centers and seams. **SLIPSTITCH** pressed edge over seam.
- With **RIGHT** sides together, pin band (4) sections together, having raw edges even. Stitch outer edges together, leaving one end open. Trim seam and corners.
- Turn band right side out. Press, pressing seam allowances to inside on raw edge.
- On **OUTSIDE**, pin band to crown placing lower edge along seam, having ends meet at center back. **SLIPSTITCH** ends. Tack band to brim at centers and sides.

TOTE B

NOTE: All seams are 5/8" (1.5cm) unless otherwise indicated.

- Construct two straps as follows: Apply heavy weight interfacing to strap (6) sections. See **GENERAL DIRECTIONS FOR HEAVY WEIGHT INTERFACING**. Fold strap in half lengthwise with **WRONG** sides together. Press, setting in crease.
- Open out long edges of strap and turn them to **WRONG** side so that they meet at the crease. Press.
- Fold strap in half lengthwise, bringing pressed edges together. Stitch close to both long edges.
- Apply headliner interfacing to front and back (5). See **GENERAL DIRECTIONS FOR HEAVY WEIGHT INTERFACING**. On **OUTSIDE**, pin each strap to front and back centering along placement lines, having raw edges even. **EDGE STITCH** straps in place, as shown. Stitch in a square and diagonally across, as shown. Baste lower raw edges together. Stitch across straps approximately 1-1/4" above stitching.

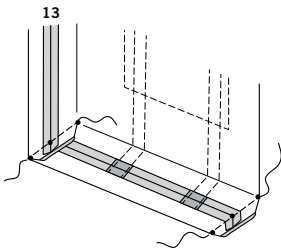
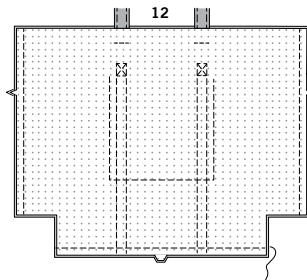
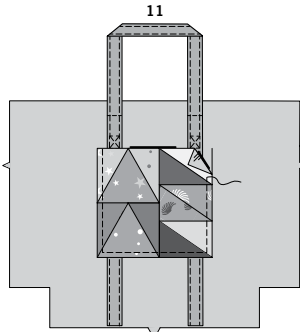
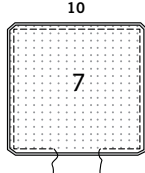
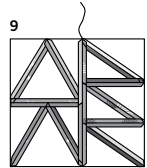
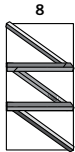
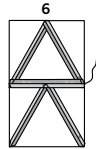
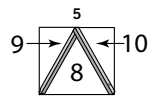

5. Construct LEFT side of patch as follows:
With RIGHT sides together, pin patch 2 (9) and patch 3 (10) to each side of patch 1 (8). Stitch in a 1/4" (6mm) seam. Press seams open.
6. Construct second patch in same manner as first patch.
With RIGHT sides together pin upper and lower patches together, as shown. Stitch. Press seam open.
7. Construct three RIGHT patches as follows:
Pin two patch 4 (11) sections together along angled edge forming rectangle. Stitch. Press seam open.
8. Stich three patch sections together, forming panel, as shown.
9. With RIGHT sides together, stitch RIGHT patch to LEFT patch on long edge. Stitch. Press seam open.
10. Apply fusible fleece **INTERFACING** to wrong side of pocket lining (7).
With RIGHT sides together, pin lining to pocket having raw edges even. Stitch, leaving an opening at lower edge of turning. Trim corners.

11. Turn pocket RIGHT side out. Press.
On **OUTSIDE**, pin pocket to one front and back section, placing finished edges along placement lines. **TOPSTITCH** lower and side edges of pocket in place.

12. With RIGHT sides together, stitch front and back sections together at side and lower edges.

13. To form corners and stitch dart seams, fold corners matching seams and small dots. Stitch between outer small dots.

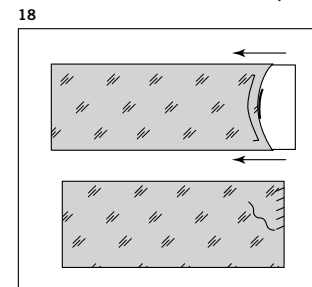
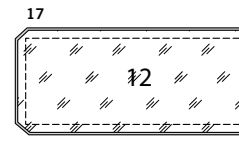
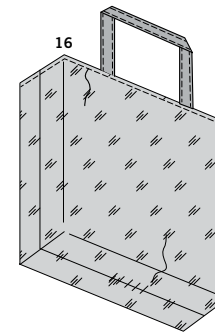
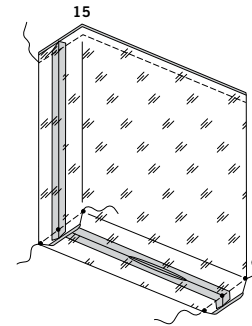
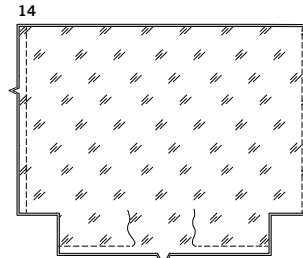

14. With RIGHT sides together, stitch front and back **LINING** sections together at side and lower edges, leaving an opening at lower edge, large enough for turning.

15. Stitch corners same as for bag.
With RIGHT sides together, insert bag into lining. Stitch upper edge. Trim.

16. Turn bag RIGHT side out through opening. Press. **SLIPSTITCH** opening closed.
TOPSTITCH upper edge of bag.

17. To make insert for bottom, pin base (12) sections together having raw edges even. Stitch, leaving one end open. Trim seam and corners.

18. Turn base RIGHT side out. Press. Pressing raw seam allowances to **INSIDE**.
Cut a piece of plastic canvas OR cardboard the measurement of finished base. Insert plastic into opening in base. **SLIPSTITCH** opening edges together.

S9937

4 of 4

ZIPPER CASE C, D, E

NOTE: All seams are 1/4" (6mm) unless otherwise indicated.
View C will be shown unless otherwise indicated.

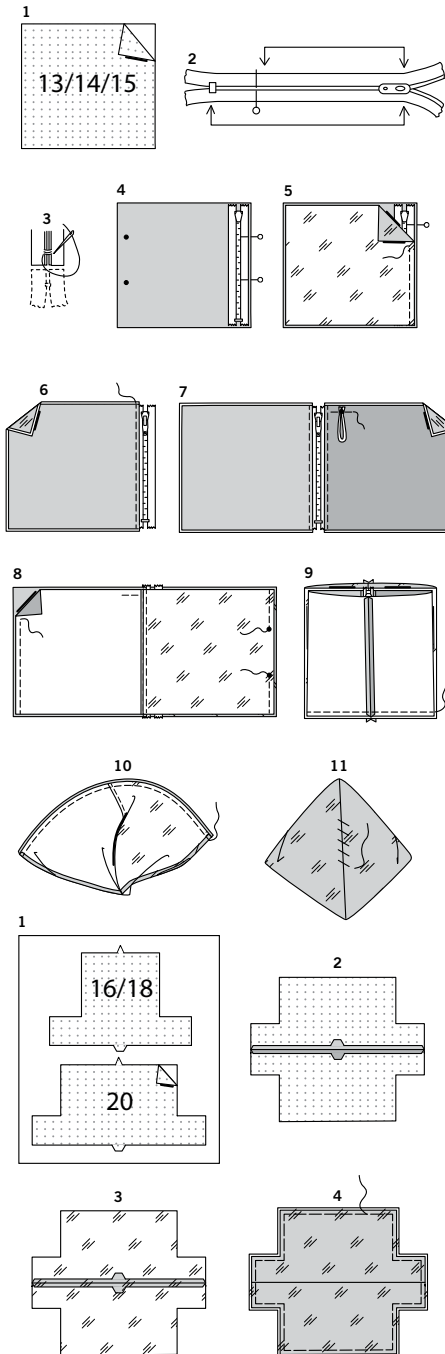

1. Fuse **INTERFACING** to case (13, 14 OR 15) fabric and contrast sections.
2. It will be necessary to adjust the length of your zipper. Measure the side of case edge, minus 1/2" (1.3cm). Close the zipper and measure from the tab down along the teeth to the length needed. Mark new length.
3. With matching buttonhole twist or heavy-duty thread, make several overcast stitches across zipper teeth. Trim away lower end of zipper tape.
4. With zipper facing down, pin closed zipper to edge opposite small dots having raw edges even.
5. With **RIGHT** sides together, pin lining to fabric (over zipper), having raw edges even. Using an adjustable zipper foot, stitch in a 1/4" (6mm) seam.
6. Press fabric and lining away from zipper, with **RIGHT** sides facing out. **EDGESTITCH** pressed edge of bag being sure to catch in bag lining.
7. Stitch remaining side of the zipper to remaining contrast and lining sections in the same manner as fabric. Cut a piece of ribbon as desired, or approximately 3" (7.5cm). Fold ribbon in half forming a loop. On **OUTSIDE**, center loop over small dot, as shown. Baste.
8. With **RIGHT** sides together, pin fabric and contrast sections together on side edge. Stitch, as shown. Pin lining sections together on side edge, matching small dots. Stitch leaving an opening between small dots. Back-stitch to reinforce.
9. Press seams open. Bring seams toward center to meet zipper, having raw edges even. Press. Pin lower edges together leaving end with top-stop open. Stitch in a 1/4" (6mm) seam.
10. Open zipper. Pin remaining fabric and contrast sections together, pinning lining sections together as shown. Stitch in one continuous seam. Trim.
11. Turn case **RIGHT** side out through opening. **SLIPSTITCH** OR **EDGESTITCH** opening closed.

Cut a piece of ribbon as desired. Tie ribbon to zipper pull as shown on front of envelope.

ZIPPER CASE F, G, H

NOTE: All seams are 1/4" (6mm) unless otherwise indicated.
View H will be shown unless otherwise indicated.

1. Fuse **INTERFACING** to case (16, 18 OR 20) fabric and contrast sections.
2. With **RIGHT** sides together, stitch case sections together matching double notches. Press seam open.
3. Stitch lining sections in same manner as fabric.
4. With **WRONG** sides together, pin lining to case having raw edges even. Baste raw edges together.

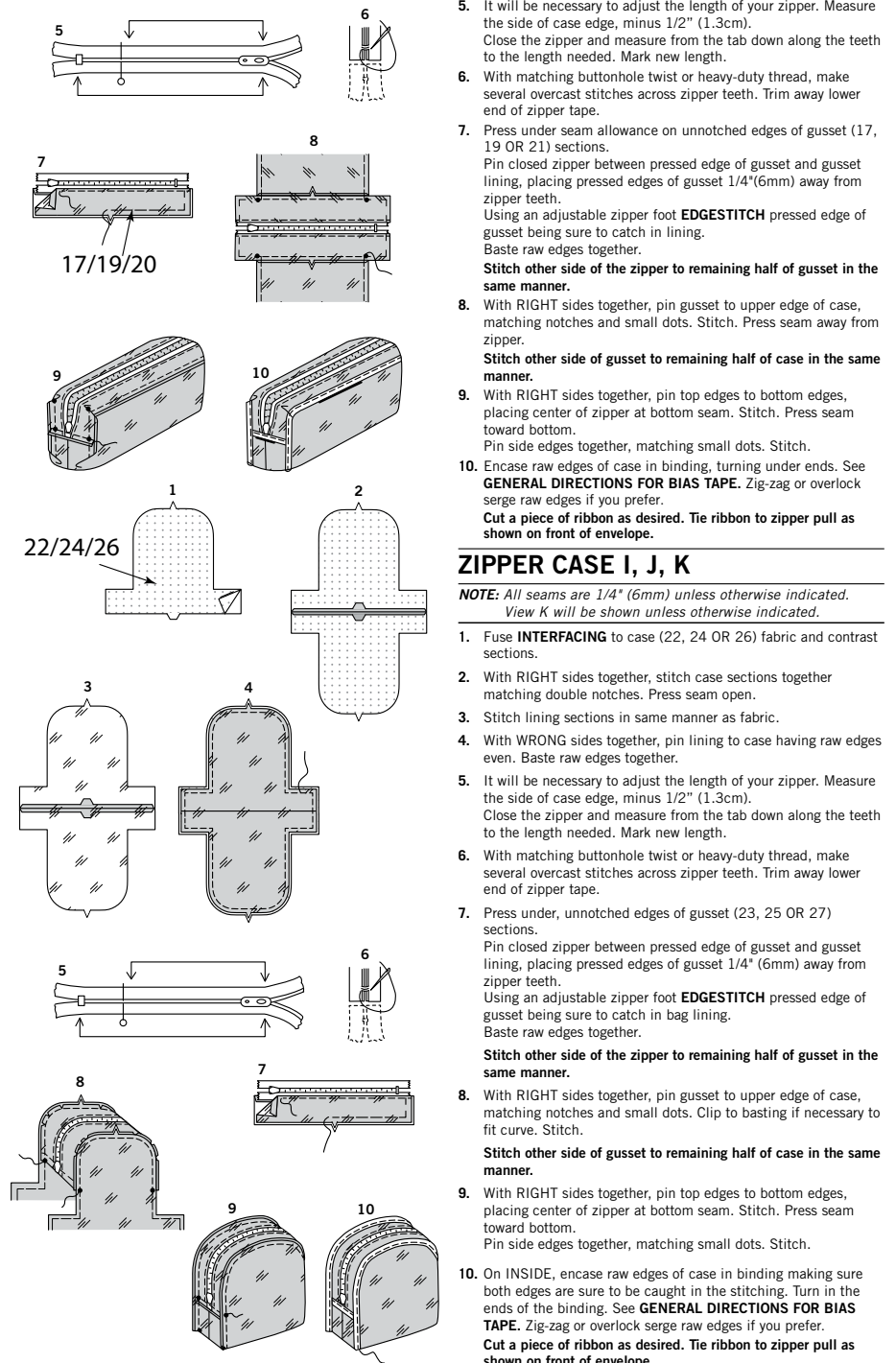

5. It will be necessary to adjust the length of your zipper. Measure the side of case edge, minus 1/2" (1.3cm). Close the zipper and measure from the tab down along the teeth to the length needed. Mark new length.
6. With matching buttonhole twist or heavy-duty thread, make several overcast stitches across zipper teeth. Trim away lower end of zipper tape.
7. Press under allowance on unnotched edges of gusset (17, 19 OR 21) sections. Pin closed zipper between pressed edge of gusset and gusset lining, placing pressed edges of gusset 1/4" (6mm) away from zipper teeth. Using an adjustable zipper foot **EDGESTITCH** pressed edge of gusset being sure to catch in lining. Baste raw edges together. **Stitch other side of the zipper to remaining half of gusset in the same manner.**
8. With **RIGHT** sides together, pin gusset to upper edge of case, matching notches and small dots. Stitch. Press seam away from zipper. **Stitch other side of gusset to remaining half of case in the same manner.**
9. With **RIGHT** sides together, pin top edges to bottom edges, placing center of zipper at bottom seam. Stitch. Press seam toward bottom. Pin side edges together, matching small dots. Stitch.
10. Encase raw edges of case in binding, turning under ends. See **GENERAL DIRECTIONS FOR BIAS TAPE**. Zig-zag or overlock serge raw edges if you prefer. **Cut a piece of ribbon as desired. Tie ribbon to zipper pull as shown on front of envelope.**

ZIPPER CASE I, J, K

NOTE: All seams are 1/4" (6mm) unless otherwise indicated.
View K will be shown unless otherwise indicated.

1. Fuse **INTERFACING** to case (22, 24 OR 26) fabric and contrast sections.
2. With **RIGHT** sides together, stitch case sections together matching double notches. Press seam open.
3. Stitch lining sections in same manner as fabric.
4. With **WRONG** sides together, pin lining to case having raw edges even. Baste raw edges together.
5. It will be necessary to adjust the length of your zipper. Measure the side of case edge, minus 1/2" (1.3cm). Close the zipper and measure from the tab down along the teeth to the length needed. Mark new length.
6. With matching buttonhole twist or heavy-duty thread, make several overcast stitches across zipper teeth. Trim away lower end of zipper tape.
7. Press under, unnotched edges of gusset (23, 25 OR 27) sections. Pin closed zipper between pressed edge of gusset and gusset lining, placing pressed edges of gusset 1/4" (6mm) away from zipper teeth. Using an adjustable zipper foot **EDGESTITCH** pressed edge of gusset being sure to catch in bag lining. Baste raw edges together. **Stitch other side of the zipper to remaining half of gusset in the same manner.**
8. With **RIGHT** sides together, pin gusset to upper edge of case, matching notches and small dots. Clip to basting if necessary to fit curve. Stitch. **Stitch other side of gusset to remaining half of case in the same manner.**
9. With **RIGHT** sides together, pin top edges to bottom edges, placing center of zipper at bottom seam. Stitch. Press seam toward bottom. Pin side edges together, matching small dots. Stitch.
10. On **INSIDE**, encase raw edges of case in binding making sure both edges are sure to be caught in the stitching. Turn in the ends of the binding. See **GENERAL DIRECTIONS FOR BIAS TAPE**. Zig-zag or overlock serge raw edges if you prefer. **Cut a piece of ribbon as desired. Tie ribbon to zipper pull as shown on front of envelope.**



Congrats!

You've completed your sewing adventure

**SHARE
YOUR** LOOK



Post your pattern and tag us
@simplicity_creative_group and **#simplicitypatterns**
for a chance to be featured on our social media.

Look for more PDF patterns at [simplicity.com](https://www.simplicity.com)

Have a question or need help with your sewing project call us at
1-888-588-2700



Simplicity ©2024 a division of IG Design Group Americas Inc. • Atlanta, GA 30342 USA www.thedesigngroup.com • All Rights Reserved. www.simplicity.com • Made in the U.S.A. Fabriqué aux États-Unis.

To be used for individual private home use only and not for commercial or manufacturing purposes. • A usage privé seulement et non à des fins commerciales ou de production en série. • Para uso privado solamente, no se puede utilizar con propósitos de comercialización o de producción en serie.