

S9887

Simplicity



Designed and printed in USA.

Average

WOMEN'S DRESSES WITH LENGTH VARIATIONS

Suggested Fabrics: Challis, Charmeuse, Crepe, Double Georgette, Lightweight Cotton Blends, Rayon, Silky Types. **Interfacing:** Lightweight Fusible.

Notions: **A,B:** One pkg. of 1/2" (1.3cm) single fold bias tape. **A:** One 24" (61cm) invisible zipper. **B,C:** One 22" (56cm) invisible zipper.

Sizes	20W	22W	24W	26W	28W	30W	32W	34W	36W	38W
European	46	48	50	52	54	56	58	60	62	64

BODY MEASUREMENTS: Select pattern size based on body measurements

Bust	42	44	46	48	50	52	54	56	58	60	Ins.
Waist	35	37	39	41½	44	46½	49	51½	53	54½	"
Hip-9" below waist	44	46	48	50	52	54	56	58	60	62	"
Back-neck to waist	17¼	17%	17½	17%	17¾	17%	18	18%	18¼	18%	"

Dress A 60** 1¼ 1¼ 1¼ 1¼ 1¼ 1¼ 1¼ 1¼ 1¼ 1¼ Yds.

Contrast 1 (Skirt Middle Front and Back, Skirt Left Back)

60** 1¼ 1¼ 1¼ 1¼ 1¼ 1¼ 1¼ 1¼ 1¼ 1¼ Yds.

Contrast 2 (Skirt Right Front and Back)

60** ¾ ¾ ¾ ¾ 1 1 1 1 1 1 Yd.

Interfacing 20" - ¾ yd.

Dress B 60** 1¼ 1¼ 1¼ 1¼ 1¼ 1¼ 2 2 2 2 Yds.

Contrast 1 (Skirt Middle Front and Back, Skirt Left Back)

60** 1¼ 1¼ 1¼ 1¼ 1¼ 1¼ 1¼ 1¼ 1¼ 1¼ Yds.

Contrast 2 (Skirt Right Front and Back)

60** 1¼ 1¼ 1¼ 1¼ 1¼ 1¼ 1¼ 1¼ 1¼ 1¼ Yds.

Interfacing B,C - 20" - ¾ yd.

Dress C 60** - 2 yd.

Contrast 1 (Skirt Middle Front and Back, Skirt Left Back)

60** 1 1 1 1 1 1 1¼ 1¼ 1¼ 1¼ Yds.

Contrast 2 (Skirt Right Front and Back)

60** - ¾ yd.

NOTE: Please refer to the sewing instructions for **FINISHED GARMENT MEASUREMENTS**.

*with nap **without nap

Moins Facile

ROBES AVEC VARIATIONS DE LONGUEURS POUR FEMMES

Tissus Conseillés: Challis, Charmeuse, Crêpe, Crêpe Georgette double, Cottonnades légères, Rayonne, Sortes de soie. **Entoilage:** thermocollant léger.

Mercerie: **A,B:** 1 paquet de ruban de biais simple de 1.3cm. **A:** 1 fermeture à glissière invisible 61cm. **B,C:** 1 fermeture à glissière invisible 56cm.

Tailles	20W	22W	24W	26W	28W	30W	32W	34W	36W	38W
Françaises	48	50	52	54	56	58	60	62	64	66
Européen	46	48	50	52	54	56	58	60	62	64

MESURES DU CORPS: Choisissez la taille du patron basée sur les mesures du corps

Poitrine	107	112	117	122	127	132	137	142	147	152	cm
Taille	89	94	99	105	112	118	124	130	134	138	"

Hanches (23cm au-dessous de la taille)

	112	117	122	127	132	137	142	147	152	157	cm
Dos du cou à la taille	44	44	44.5	45	45	45.5	46	46	46.5	47	"

Robe A 150cm* 1.5 1.6 1.6 1.6 1.6 1.6 1.6 1.6 1.6 1.7 1.7 m

Contraste 1 (Jupe partie milieu devant et dos, Jupe dos gauche)

150cm* 1.1 1.1 1.1 1.1 1.1 1.1 1.1 1.1 1.1 1.1 1.1 m

Contraste 2 (Jupe devant et dos droits)

150cm* 0.8 0.8 0.8 0.8 0.8 0.9 0.9 0.9 0.9 0.9 0.9 m

Entoilage 51cm - 0.6m

Robe B 150cm* 1.7 1.7 1.7 1.7 1.7 1.7 1.7 1.7 1.7 1.8 m

Contraste 1 (Jupe partie milieu devant et dos, Jupe dos gauche)

150cm* 1.3 1.3 1.3 1.3 1.3 1.3 1.4 1.4 1.4 1.4 m

Contraste 2 (Jupe devant et dos droits)

150cm* 0.9 1.0 1.0 1.0 1.0 1.0 1.0 1.0 1.0 1.0 m

Entoilage B,C - 51cm - 0.3m

Robe C 150cm* - 1.8m

Contraste 1 (Jupe partie milieu devant et dos, Jupe dos gauche)

150cm* 0.9 0.9 0.9 0.9 0.9 0.9 1.0 1.0 1.0 1.0 m

Contraste 2 (Jupe devant et dos droits)

150cm* - 0.7m

NOTE: S'il vous plaît, reportez-vous aux instructions de couture pour les **MESURES DES VÊTEMENTS FINI**.

*avec sens **sans sens

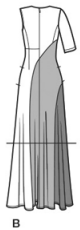

Simplicity®

Thank you for purchasing this Simplicity pattern. We made every effort to provide you with a high quality product.

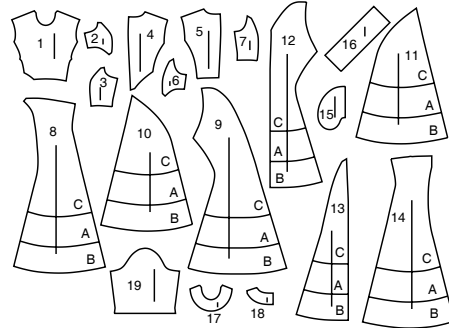
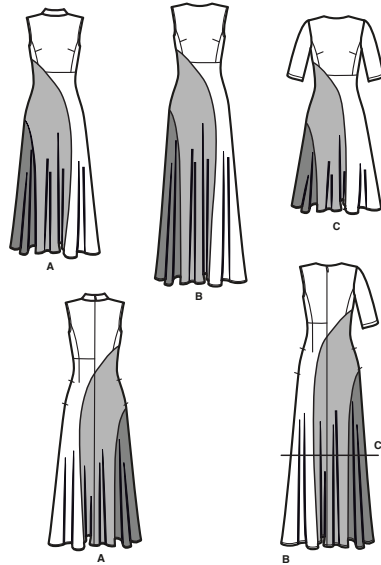

- 1 Bodice Front-A,B,C
- 2 Bodice Right Side Front-A,B,C
- 3 Bodice Left Side Front-A,B,C
- 4 Bodice Right Back-A,B,C
- 5 Bodice Left Back-A,B,C
- 6 Bodice Right Side Back-A,B,C
- 7 Left Bodice Side Back-A,B,C
- 8 Skirt Left Front-A,B,C
- 9 Skirt Middle Front-A,B,C
- 10 Skirt Right Front-A,B,C
- 11 Skirt Right Back-A,B,C
- 12 Skirt Middle Back (Right)-A,B,C
- 13 Skirt Middle Back (Left)-A,B,C
- 14 Skirt Left Back-A,B,C
- 15 Pocket-A,B,C
- 16 Neckband-A
- 17 Front Facing-B,C
- 18 Back Facing-B,C
- 19 Sleeve-C

The Pattern General Directions

SYMBOLS

- ↔ GRAIN LINE Place on straight grain of fabric parallel to selvage
- ⇓ PLACE SOLID LINE on fold of fabric.
- CENTER FRONT OR BACK OF garment.
- ▽ NOTCHES
- DOTS
- CUTTING LINE
- == LENGTHEN OR SHORTEN LINES

SEAM ALLOWANCE: 5/8" (1.5cm) unless otherwise stated is included but not printed on MULTI-SIZE PATTERNS. Mark your size with colored felt tip pen. See chart on tissue for how to use MULTI-SIZE PATTERNS.

ADJUST IF NEEDED

Make adjustments before placing pattern on fabric.

TO LENGTHEN: Cut pattern between lengthen or shorten lines. Spread pattern evenly, the amount needed and tape to paper.

TO SHORTEN: At lengthen or shorten lines, make an even pleat taking up amount needed. Tape in place.

When lengthen or shorten lines are not given, make adjustments at lower edge of pattern.

Cutting/Marking

BEFORE CUTTING:

PRESS pattern pieces with a warm dry iron. PRE-SHRINK fabric by pre-washing washables or steam-pressing non-washables.

CIRCLE your cutting layout.

PIN pattern to fabric as shown in Cutting Layouts.

- FOR DOUBLE THICKNESS: Fold fabric with RIGHT sides together.
- FOR SINGLE THICKNESS: Place fabric RIGHT side up.
- FOR PILE, SHADED OR ONE WAY DESIGN FABRICS: Use "with nap" layouts

AFTER CUTTING:

Transfer markings to WRONG side of fabric before removing pattern. Use pin and chalk method or dressmaker's tracing paper and wheel.

To Quick Mark:

- Snip edge of fabric to mark notches, ends of fold lines and center lines.
- Pin mark dots.

Sewing

- SEW garment following **Sewing Directions**.
- PIN or machine-baste seams matching notches.
- STITCH 5/8" (1.5 cm) seams unless otherwise stated.
- PRESS seams open unless otherwise indicated clipping when necessary so seams will lie flat.
- TRIM seams to reduce bulk, as shown below.

Trim enclosed seams into layers

Trim corners

Clip inner curves

Notch outer curves

SPECIAL CUTTING NOTES

- ★ If layout shows a piece extending past fold, cut out all pieces except piece that extends.
- ✱ Mark small arrows along both selvages indicating direction of nap or design. Fold fabric crosswise with RIGHT sides together, and cut along fold (a).
- Turn one fabric layer around so arrows on both layers go in the same direction. Place RIGHT sides together (b).

Cutting Layouts

WRONG SIDE OF FABRIC

RIGHT SIDE OF FABRIC

PATTERN PIECE WITH PRINTED SIDE UP

PATTERN PIECE WITH PRINTED SIDE DOWN

★ SEE SPECIAL CUTTING NOTES

POSITION OF PATTERN PIECES MAY VARY SLIGHTLY ACCORDING TO YOUR PATTERN SIZE

Sizes	20W	22W	24W	26W	28W	30W	32W	34W	36W	38W
European	46	48	50	52	54	56	58	60	62	64

FINISHED GARMENT MEASUREMENTS (Includes Design and Wearing Ease)

	20W	22W	24W	26W	28W	30W	32W	34W	36W	38W
A,B,C Bust	45½	47½	49½	51½	53½	55½	57½	59½	61½	63½
A,B,C Waist	38½	40½	42½	44½	46½	48½	50½	52½	54½	56½
A,B,C Hip	46	48	50	52	54	56	58	60	62	64
Width, lower edge										
Dress C	77	79	81	83	85	87	89	91	93	95
Finished back length from base of neck										
Dress A	45¾	46	46¾	46¾	46¾	47	47¼	47¼	47¾	48
Dress B	51¾	52	52¾	52¾	52¾	53	53¼	53¼	53¾	54
Dress C	38¾	39	39¾	39¾	39¾	40	40¼	40¼	40¾	41

CONTRAST 1

USE PIECES 9 12 13

60" (150CM) WITH NAP ALL SIZES

CONTRAST 2

USE PIECES 10 11

60" (150CM) WITH NAP ALL SIZES

DRESS B

USE PIECES 1 2 3 4 5 6 7 8 14 15 17 18

60" (150CM) WITH NAP ALL SIZES

DRESS A

USE PIECES 1 2 3 4 5 6 7 8 14 15 16

60" (150CM) WITH NAP ALL SIZES

INTERFACING A

USE PIECE 16

20" (51CM) ALL SIZES

CONTRAST 1

USE PIECES 9 12 13

60" (150CM) WITH NAP ALL SIZES

S9887

2 of 4

CONTRAST 2

USE PIECES 10 11

60" (150CM)
WITH NAP
ALL SIZES

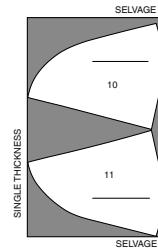

INTERFACING B,C

USE PIECES 17 18

20" (51CM)
ALL SIZES

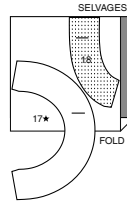

DRESS C

USE PIECES 1 2 3 4 5 6 7 8 14 15 17 18 19

60" (150CM)
WITH NAP
ALL SIZES

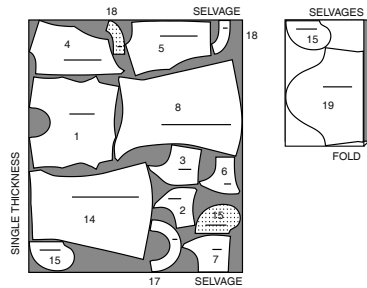

CONTRAST 1

USE PIECES 9 12 13

60" (150CM)
WITH NAP
ALL SIZES

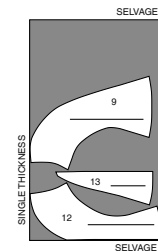

CONTRAST 2

USE PIECES 10 11

60" (150CM)
WITH NAP
ALL SIZES

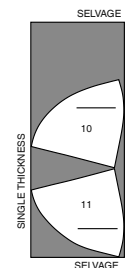

SEWING TUTORIALS



Build your skills viewing short, easy-to-follow videos at simplicity.com/sewingtutorials

Sewing Directions

FABRIC KEY



Read **General Directions** on page 1 before you begin.

Sewing methods in **BOLD TYPE** have Sewing Tutorial Video available. Scan QR CODE to watch videos:

- SLEEVE** – see **Armholes/Sleeves**: “sewing a set in sleeve” video.
- DART** - see **Darts**: “sewing flat dart” video.
- EASE/GATHER** - see **Gathering**: “sewing two row gathers” video.
- STAYSTITCH** - see **Machine Stitches**: “how to stay-stitching” video.
- STITCH IN THE DITCH** - see **Machine Stitches**: “how to stitch in the ditch” video.
- UNDERSTITCH** - see **Machine Stitches**: “how to understitch” video.
- INVISIBLE ZIPPER** - see **Zipper**: “sewing an invisible zipper” video.
- SLIPSTITCH** - Slide needle through a folded edge, then pick up a thread of underneath fabric.

PATTERN PIECES WILL BE IDENTIFIED BY NUMBERS THE FIRST TIME THEY ARE USED.

STITCH SEAMS WITH RIGHT SIDES TOGETHER UNLESS OTHERWISE STATED.

NOTE: Under each sub-heading, the first view will be illustrated, unless otherwise illustrated.

DRESS A, B, C

BODICE FRONT

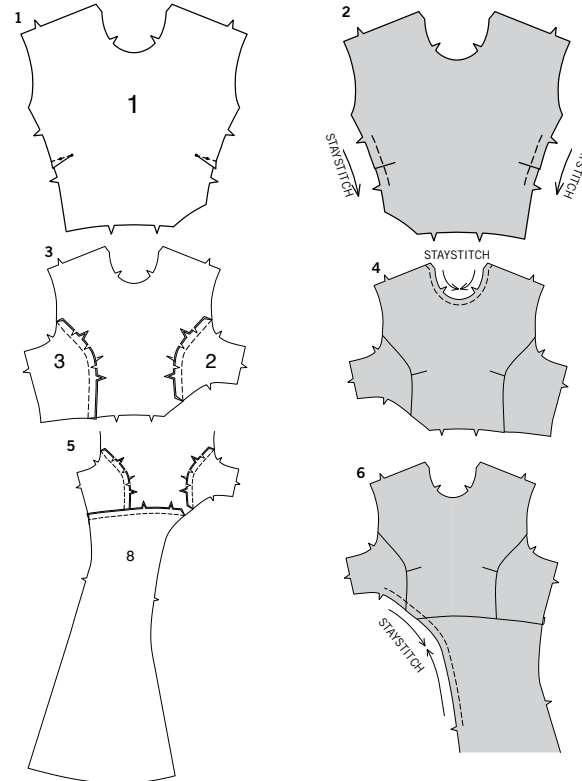

- 1.** To make **DARTS** on Bodice front (1), with **RIGHT** sides together, bring broken lines together, matching small dots. Stitch along broken line from wide end to point. Press dart down.
- 2.** **STAYSTITCH** side front edges of bodice front between notches, in the direction of arrows.
- 3.** Pin Bodice right side front (2) to right side edge of bodice. Clip side edge of front to staystitching in the curved area so that it fits the right side front. Stitch; press seams toward front. Pin Bodice left side front (3) to left side edge of bodice. Clip side edge of front to staystitching in the curved area so that it fits the left side front. Stitch; press seams toward front.
- 4.** **STAYSTITCH** neck edge of bodice front 1/2" (1.3cm) from cut edge in direction of arrows.

SKIRT FRONT LEFT AND RIGHT MIDDLE SECTION

- 5.** Pin Skirt left front (8) to bodice front, matching centers. Stitch; press seams toward bodice.
- 6.** **STAYSTITCH** right side edge of skirt/bodice front between notches, in the direction of arrows.

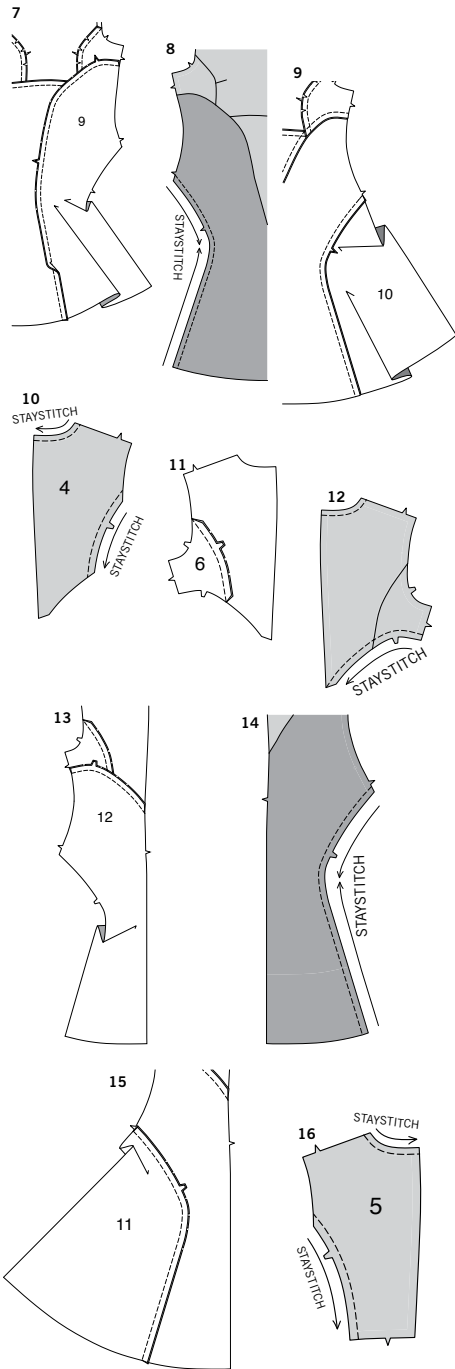

- 7.** Pin Skirt middle front (9) to right side edge of bodice/skirt, matching notches, clipping skirt left front/bodice front where necessary. Stitch; press seams toward right side.

RIGHT FRONT SECTION

- 8.** **STAYSTITCH** right side edge of skirt middle front along curve, in the direction of arrows.
- 9.** Pin Skirt right front (10) to skirt middle front, matching notches, clipping skirt middle front where necessary. Stitch; press seams toward right side.

RIGHT BACK BODICE RIGHT SIDE

- 10.** **STAYSTITCH** neck edge of Bodice right back (4) 1/2" (1.3cm) from cut edge in direction of arrows. **STAYSTITCH** right side edge of bodice right back, in the direction of arrows.
- 11.** Pin Bodice right side back (6) to bodice right back. Clip side edge of bodice right back to staystitching in the curved area so that it fits bodice right side back. Stitch; press seams toward bodice right back.
- 12.** **STAYSTITCH** lower edge of right bodice, in the direction of arrows.

SKIRT RIGHT SIDE

- 13.** Pin upper edge of Skirt middle back (12) to lower edge of bodice. Clip bodice to staystitching in the curved area so that it fits the skirt. Stitch; press seams toward bodice.
- 14.** **STAYSTITCH** long curved edge of skirt middle back, in the direction of arrows.

- 15.** Pin Skirt right back (11) to skirt middle back. Clip side edge of skirt middle back to staystitching in the curved area so that it fits skirt right back. Stitch; press seams toward skirt middle back.

LEFT BACK BODICE LEFT SIDE

- 16.** **STAYSTITCH** neck edge of Bodice left back (5) 1/2" (1.3cm) from cut edge in direction of arrow. **STAYSTITCH** left side edge of bodice left back, in the direction of arrows.

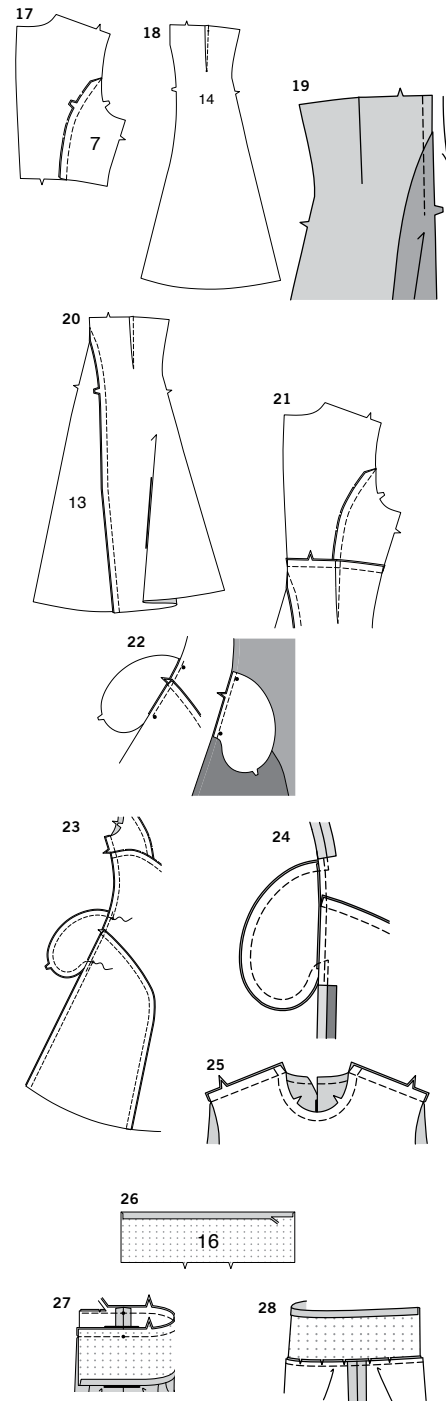

- 17.** Pin Left bodice side back (7) to bodice left back. Clip side edge of bodice left back to staystitching in the curved area so that it fits left bodice side back. Stitch; press seams toward bodice left back.

SKIRT LEFT SIDE

- 18.** To make **DART** on Skirt left back (14), with **RIGHT** sides together, bring broken lines together, matching small dots. Stitch along broken line from wide end to point. Press dart toward center back.
- 19.** **STAYSTITCH** center back edge of left back above notches, in the direction of arrows.

- 20.** Pin Skirt middle back (13) to skirt left back, clipping if necessary. Stitch; press seams toward skirt middle back.

- 21.** Pin upper edge of skirt to lower edge of bodice back, matching notches and seam to dart. Stitch; press seams toward bodice.

POCKET AND SIDE SEAM

NOTE: Apply pockets to front and back as follows:

- 22.** With right sides together, pin Pocket (15) to dress front and back, matching large dots, having raw edges even. Stitch in 3/8" (1cm) seam. Press seam toward pocket, pressing pocket out.

- 23.** Pin front to back at side seams, matching large dots. In one continuous stitching, stitch side seams and pockets, squaring stitching at large dots.

- 24.** Clip dress back seam allowance at ends of pocket, as shown. Press seam open above and below clips. Press pocket toward front.

- 25.** Stitch back to front at shoulders.

NECK BAND A

- 26.** Apply fusible interfacing to **WRONG** side of Neck band (16), following manufacturer's direction. Press under 5/8" (1.5cm) on long unnotched edge of neck band. Trim pressed edge to 3/8" (1cm).

- 27.** With right sides together, pin neck band to neck edge, matching notches and centers, placing dots at shoulder seams. Stitch neck edge, stretching neck band to fit. Trim seam; clip curves.

- 28.** Press neck band out, pressing seam toward neck band.

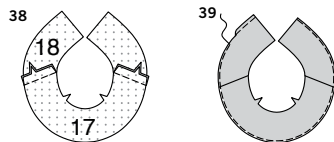
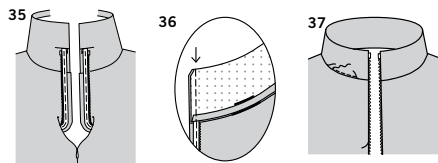
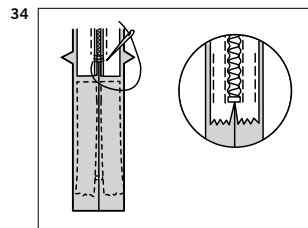
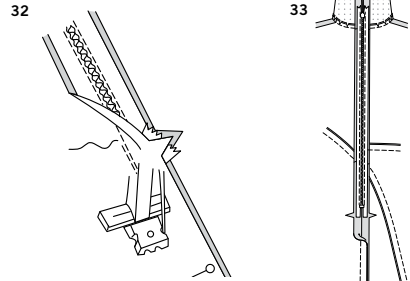
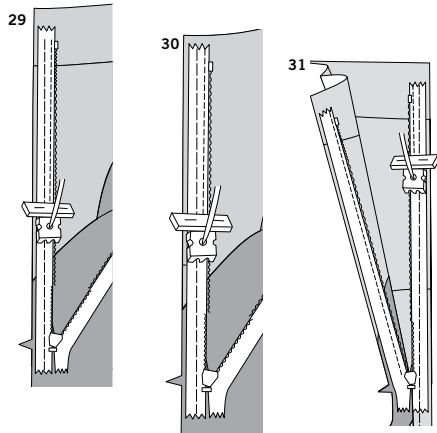

ZIPPER

29. For View A: Open the zipper and press the tape using a cool iron. On OUTSIDE, pin RIGHT side of the zipper face down on the RIGHT side of the zipper opening. Have the coil along the seam line, the tape within the seam allowance and the top stop 1/8" (3mm) below foldline on neck band, as shown. Hand-baste along center of the tape. Position zipper foot at the top of the zipper with RIGHT groove of the foot over coil. Stitch along tape to the notch. Back-stitch to reinforce.

30. For Views B, C: Open the zipper and press the tape using a cool iron. On OUTSIDE, pin RIGHT side of the zipper face down on the RIGHT side of the zipper opening. Have the coil along the seam line, the tape within the seam allowance and the top stop 3/4" (2cm) below upper edge, as shown. Hand-baste along center of the tape. Position zipper foot at the top of the zipper with RIGHT groove of the foot over coil. Stitch along tape to the notch. Back-stitch to reinforce.

31. For Views B, C, D: Pin the remaining half of the zipper to the LEFT side of the zipper opening in same manner. Make sure the upper and lower edges of the dress are even. Hand-baste along center of the tape. Position zipper foot at the top of the zipper with LEFT groove of the foot over the coil. Stitch along tape to the notch. Back-stitch to reinforce.

32. Close zipper and check that it is invisible from the OUTSIDE. Pull the free ends of the zipper tape away from the seam allowance. Pin remaining center back seam together below zipper. Position zipper foot all the way to the LEFT so the needle goes down through the outer notch of the foot. Start stitching seam 1/4" (6mm) above lowest stitch and slightly to the LEFT.

33. Stitch seam for about 3" (7.5cm). Stitch remainder of seam using your regular presser foot.

34. If the zipper is longer than the opening, using a strong thread, hand-sew a few small stitches across ends of coils at end of opening. Trim away lower end of zipper tape to within 5/8" (1.5cm) of hand-stitches. If you prefer, open out each seam allowance at end of zipper and stitch tape to seam allowance.

NECK BAND FINISH A

35. Open out center back opening edges of dress, rolling the zipper teeth away from the opening edge.

36. Turn neck band to outside along foldline, tapering upper end of zipper tape. Pin back opening edges together. Using an adjustable zipper foot, stitch 1/2" (1.3cm) from back edges, keeping zipper teeth free. Trim corners. Do not trim center back edges.

37. Turn neck band to INSIDE along foldline, rolling zipper teeth back in place; press. Pin pressed edge of neck band just over seam, stretching where necessary, placing pins on outside. On OUTSIDE, stitch in the ditch or groove of seam, between zipper, catching in finished edge of neck band on INSIDE. **STITCH IN THE DITCH TIP:** To conceal the stitches in the ditch or groove of seam, try using a zipper foot, spreading the dress and neck band away from the seam with your fingers.

FRONT AND BACK FACING B, C

38. Apply fusible interfacing to WRONG side of Front facing (17) and each Back facing (18), following manufacturer's direction. Stitch each back facing to front facing at shoulders.

39. To finish lower edge, stitch 1/4" (6mm) from edge, turn under along stitching and stitch OR zig-zag over the edge OR overlock/serge over the edge.

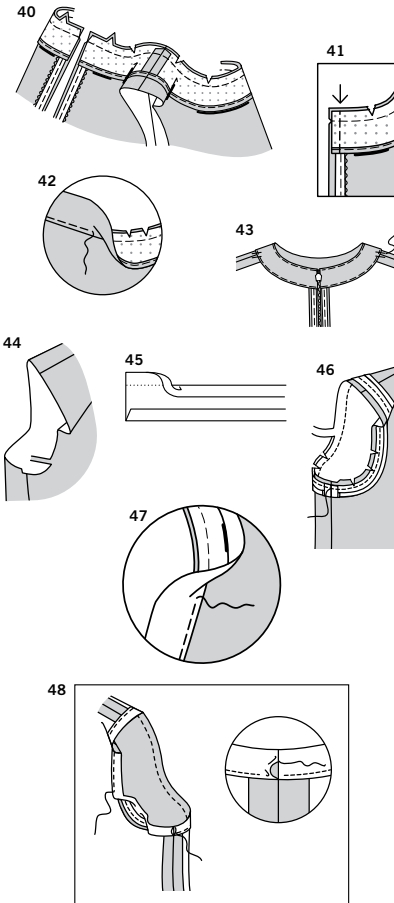

40. Open out center back opening edges of dress, rolling the zipper teeth away from the opening edge. With RIGHT sides together, pin facing to neck edge, matching centers and shoulder seams. Stitch neck edge. Trim seams; clip curves.

41. Pin back opening edges together. Using an adjustable zipper foot, stitch across facing 1/2" (1.3cm) from back edges, keeping zipper teeth free. Trim corners. Do not trim center back edges.

42. UNDERSTITCH by pressing facing and seam away from dress, stitching through facing and seam allowances close to seam as far as possible.

43. Turn facing and back edges to INSIDE, rolling zipper teeth back in place; press. To keep the facing from rolling to OUTSIDE, secure it at the seam allowances by tacking it by hand.

ARMHOLE FACING A, B

44. NOTE: Trim away 1/4" (6mm) from armhole edges of dress front and back before stitching seams.

45. Open out one edge of single fold bias tape.

46. With right sides together, pin tape to armhole edge, having crease 3/8" (1cm) from raw edge, turning under and lapping one end at underarm seam. Stitch in a 3/8" (1cm) seam. Trim seam to a scant 1/4" (6mm). Clip curves.

47. UNDERSTITCH by pressing tape and seam away from dress, stitching through tape and seam allowances close to seam.

48. Turn tape to INSIDE; press. Baste close to inner edge of tape. On OUTSIDE, top-stitch as basted. **SLIPSTITCH** ends of tape together.

SLEEVE C

49. EASESTITCH cap of Sleeve (19) between outer dots.

50. Stitch sleeve seam.

51. Turn up 1-1/4" (3.2cm) hem on lower edge of sleeve. Press under 1/4" (6mm) on raw edge. Stitch close to inner pressed edge.

52. With right sides together, pin sleeve into right armhole with center small dot at shoulder seam, matching underarm seams, notches and remaining small dots. Adjust ease; baste. Stitch. Stitch again 1/8" (3mm) away in seam allowance. Trim close to second stitching. Press seam allowances toward sleeve.

HEM

53. Stitch 1/4" (6mm) from lower edge of dress, using a long machine-stitch, as shown. Turn up 5/8" (1.5cm) hem on lower edge of dress. To form narrow hem, tuck under raw edge to meet crease. Pull thread to ease in fullness; press. Stitch hem in place.



Congrats!

You've completed your sewing adventure

**SHARE
YOUR** LOOK



Post your pattern and tag us
@simplicity_creative_group and **#simplicitypatterns**
for a chance to be featured on our social media.

Look for more PDF patterns at [simplicity.com](https://www.simplicity.com)

Have a question or need help with your sewing project call us at
1-888-588-2700



Simplicity ©2023 a division of IG Design Group Americas Inc. • Atlanta, GA 30342 USA www.thedesigngroup.com • All Rights Reserved. www.simplicity.com • Made in the U.S.A. Fabriqué aux États-Unis.

To be used for individual private home use only and not for commercial or manufacturing purposes. • A usage privé seulement et non à des fins commerciales ou de production en série. • Para uso privado solamente, no se puede utilizar con propósitos de comercialización o de producción en serie.