

S9879

Simplicity[®]



Designed and printed in USA.

Shop all the pattern brands you love @

Simplicity[®].com

Average

HOLIDAY SKIRTS, COLLAR AND APPLIQUÉS

Suggested Fabrics: Cotton Types, Satin, Taffeta. **Collar D** also in Low Pile Faux Fur, Minky Fleece, Velvet. **Lining:** Cotton Types, Lining Fabric. **Interfacing:** Lightweight Fusible.

Notions: A, B, C, D: One 7" (18cm) invisible zipper, one hook and bar closure. **Also for A, B, C:** Five-strand mini led lights each measuring 84" (213cm) long, fabric paint (optional). **Also for A:** For ruffles: 6" (15cm) tulle ribbon - four 25 yd. (23.0m) rolls (green), assorted pom poms, fabric glue. **Also for B:** For ruffles: 6" (15cm) tulle ribbon: one 25 yd. (23.0m) roll in each of eight different colors (red, pink, orange, yellow, green, turquoise, blue, and purple). **Also for C:** For ruffles: 6" (15cm) tulle ribbon: two 25 yd. (23.0m) rolls (black), one 25 yd. (23.0m) roll in each of four different colors (red, turquoise, pink, yellow). **Also for D:** For ruffles: 6" (15cm) tulle ribbon: three 25 yd. (23.0m) rolls (red), one 25 yd. (23.0m) roll (white), two-strand mini led lights each measuring 84" (213cm) long, 1 yd. (0.9m) of 3/8" (1cm) ribbon.

Sizes	6	8	10	12	14	16	18	20	22
European	32	34	36	38	40	42	44	46	48

Skirt A,B,C,D (cut crosswise)	6	8	10	12	14	16	18	20	22
45**	3	3	3	3	3	3 3/4	3 3/4	3 3/4	3 3/4
115cm*	2.7	2.7	2.7	2.7	2.7	2.7	2.9	2.9	2.9

Interfacing A,B,C,D - 20", 1 1/4 yd. (51cm, 1.1m)

Star Appliqué A - 8" x 9" (21cm x 23cm) each of fabric and paper-backed fusible web remnants

Heart Appliqué B - 6" (15cm) square each of fabric and paper-backed fusible web remnants

Ribs Appliqué C - 5" x 6" (13cm x 15cm) each of fabric and paper-backed fusible web remnants

Contrast D (Collar) - available in S,M,L

Large - 13" x 15" (33cm x 38cm) each of fabric and lining remnants

FINISHED GARMENT MEASUREMENTS (Includes Design and Wearing Ease)

Waist A,B,C,D	24 1/2	25 1/2	26 1/2	28	30	32	34	36	38	Ins.
	62	65	67	71	76	81	86	91	97	cm

Width, lower edge	154	155	156	157 1/2	159 1/2	161 1/2	163 1/2	165 1/2	167 1/2	Ins.
Skirt A,B,C,D	391	394	396	400	405	410	415	420	425	cm

Finished back length from waist	20 1/2	20 1/2	20 1/2	20 1/2	20 1/2	20 1/2	20 1/2	20 1/2	20 1/2	Ins.
Skirt A,B,C,D	52	52	52	52	52	52	52	52	52	cm

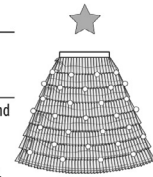

A

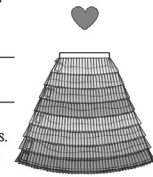

B

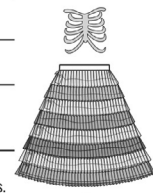

C

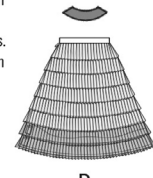

D

*with nap **without nap

Simplicity®

Thank you for purchasing this Simplicity pattern. We made every effort to provide you with a high quality product.

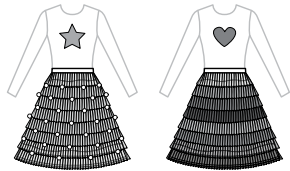

A

B

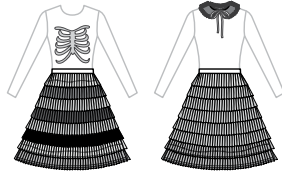

C

D

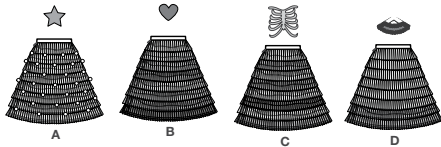

A

B

C

D

7 PIECES

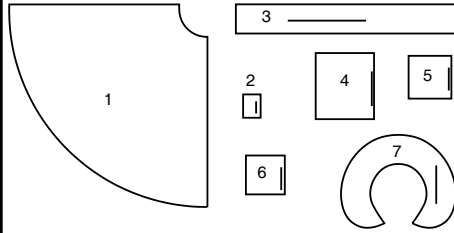

- 1 SKIRT FRONT AND BACK - A, B, C, D
- 2 POCKET - A, B, C, D
- 3 WAISTBAND - A, B, C, D
- 4 STAR APPLIQUE - A
- 5 HEART APPLIQUE - B
- 6 RIBS APPLIQUE - C
- 7 COLLAR - D

General Directions

The Pattern

- SYMBOLS**
- ↔ GRAIN LINE Place on straight grain of fabric parallel to selvage
 - ⇄ PLACE SOLID LINE on fold of fabric.
 - CENTER FRONT OR BACK of garment.
 - ▽▽ NOTCHES
 - ○ DOTS
 - CUTTING LINE
 - == LENGTHEN OR SHORTEN LINES

SEAM ALLOWANCE: 5/8" (1.5cm) unless otherwise stated is included but not printed on MULTI-SIZE PATTERNS. Mark your size with colored felt tip pen. See chart on tissue for how to use MULTI-SIZE PATTERNS.

ADJUST IF NEEDED

Make adjustments before placing pattern on fabric.

TO LENGTHEN: Cut pattern between lengthen or shorten lines. Spread pattern evenly, the amount needed and tape to paper.

TO SHORTEN: At lengthen or shorten lines, make an even pleat taking up amount needed. Tape in place.

When lengthen or shorten lines are not given, make adjustments at lower edge of pattern.

Cutting/Marking

BEFORE CUTTING: PRESS pattern pieces with a warm dry iron. PRE-SHRINK fabric by pre-washing washables or steam-pressing non-washables.

CIRCLE your cutting layout.

PIN pattern to fabric as shown in Cutting Layouts.

• FOR DOUBLE THICKNESS: Fold fabric with RIGHT sides together.

• FOR SINGLE THICKNESS: Place fabric RIGHT side up.

• FOR PILE, SHADED OR ONE WAY DESIGN FABRICS: Use "with nap" layouts

AFTER CUTTING: Transfer markings to WRONG side of fabric before removing pattern. Use pin and chalk method or dressmaker's tracing paper and wheel.

To Quick Mark:

- Snip edge of fabric to mark notches, ends of fold lines and center lines.
- Pin mark dots.

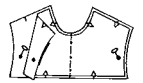

Sewing

- SEW garment following **Sewing Directions**.
- PIN or machine-baste seams matching notches.
- STITCH 5/8" (1.5 cm) seams unless otherwise stated.
- PRESS seams open unless otherwise indicated clipping when necessary so seams will lie flat.
- TRIM seams to reduce bulk, as shown below.

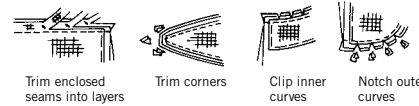

SPECIAL CUTTING NOTES

★ If layout shows a piece extending past fold, cut out all pieces except piece that extends.

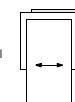

Open out fabric to single thickness. Cut extending piece on RIGHT side of fabric in position shown.

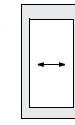

✱ Mark small arrows along both selvages indicating direction of nap or design. Fold fabric crosswise with RIGHT sides together, and cut along fold (a).

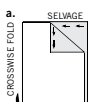

Turn one fabric layer around so arrows on both layers go in the same direction. Place RIGHT sides together (b).

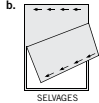

Cutting Layouts

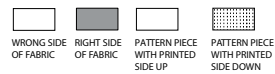

POSITION OF PATTERN PIECES MAY VARY SLIGHTLY ACCORDING TO YOUR PATTERN SIZE

SKIRT A,B,C,D (CUT CROSSWISE)

USE PIECES 1 2 3

A,B,C: CUT FIVE OF PIECE 2
D: CUT TWO OF PIECE 2

45" (115CM)
WITH NAP
ALL SIZES

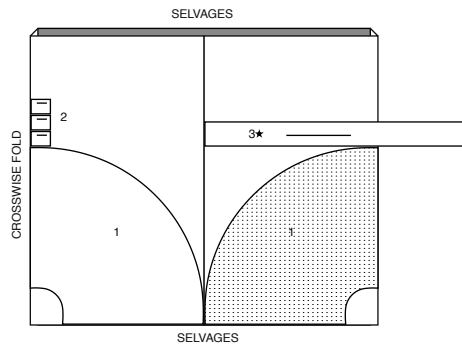

INTERFACING A,B,C

A,B,C: PIECE 3
D: PIECES 3 7

20" (51CM)
ALL SIZES

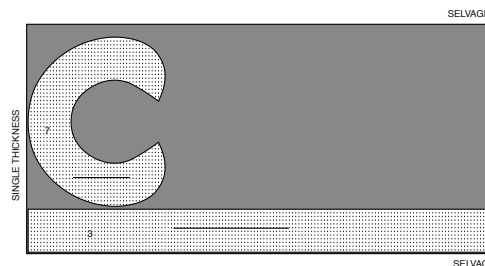

STAR APPLIQUE A

CUT ONE OF PIECE 4 EACH FROM FABRIC AND PAPER BACK FUSIBLE WEB REMNANTS

HEART APPLIQUE B

CUT ONE OF PIECE 5 EACH FROM FABRIC AND PAPER BACK FUSIBLE WEB REMNANTS

RIBS APPLIQUE C

CUT ONE OF PIECE 6 EACH FROM FABRIC AND PAPER BACK FUSIBLE WEB REMNANTS

CONTRAST COLLAR D

CUT ONE OF PIECE 7 EACH FROM FABRIC AND LINING REMNANTS

Sewing Directions

FABRIC KEY RIGHT SIDE WRONG SIDE INTERFACING LINING LINING

Read **General Directions** on page 1 before you begin.

FUR FABRICS

- Hand-baste seams to prevent slipping. For high pile fabrics, shear away 1/2" (1.3cm) within the seam allowance.
- Never place iron directly on fur fabric. Press on **WRONG** side, using a velvet board and cloth.
- Heavier fur fabrics may need some pounding with a heavy object to keep seams and edges flat.
- On **OUTSIDE**, with a pin, pick the pile up along the seams. **IMPORTANT:** When using deep pile furs, use a longer stitch and looser tension when stitching. Release the presser foot of the machine if the fabric is especially thick.

SEWING TUTORIALS



Build your skills viewing short, easy-to-follow videos at simplicity.com/sewingtutorials

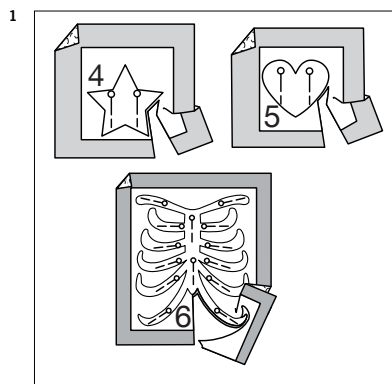

FLEECE

- Fleece fabric is strong, hard to puncture or tear and doesn't ravel or get pilly. Since cut edges of fleece fabrics do not ravel, inner edges of seams and hems can be left raw.
- When pinning pieces together, use long pins...the kind with bead heads are best because short pins tend to get lost in the fleece.
- Use a ball point needle.
- When stitching, try using a narrow zig-zag stitches, adjusting the width and length for the type of fleece you are using. Always test first on some scraps and keep for reference.
- Sew slowly and carefully the first time you stitch a seam as stitches are hard to remove.
- When sewing around shaped areas sew slowly being careful not to stretch the fleece as you feed fabric through your machine.
- Finger press or steam press on a low temperature setting using a press cloth.
- Raw edges can also be cut with pinking shears.

Sewing methods in **BOLD TYPE** have Sewing Tutorial Video available. Scan QR CODE to watch videos:

EDGESTITCH - see **Machine Stitches: "how to edgestitch"** video.

NARROW HEM - see **Hems: "sewing narrow hems"** video.

SLIPSTITCH - see **Hand Stitches: "how to slip-stitch"** video.

STAYSTITCH - see **Machine Stitches: "how to do stay-stitching"** video.

TACK - see **Hand Stitches: "how to tack"** video.

TOPSTITCH - see **Machine Stitches: "how to topstitch"** video.

PATTERN PIECES WILL BE IDENTIFIED BY NUMBERS THE FIRST TIME THEY ARE USED.

STITCH SEAMS WITH RIGHT SIDES TOGETHER UNLESS OTHERWISE STATED.

APPLIQUES A, B, C

- Apply paper backed fusible web to **WRONG** side of **STAR APPLIQUE** (4), or **HEART APPLIQUE** (5), or **RIBBS APPLIQUE** 6 following manufacturer's directions. Pin pattern to **RIGHT** side of prepared fabric. Cut out applique.

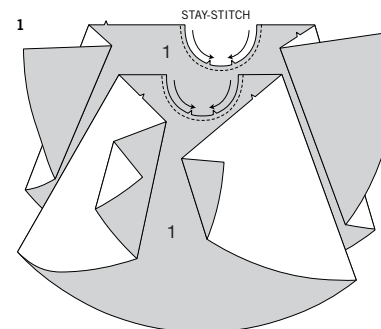
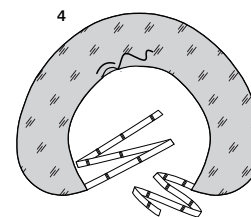
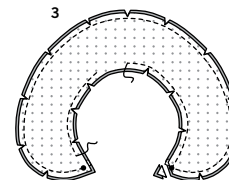
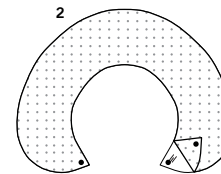
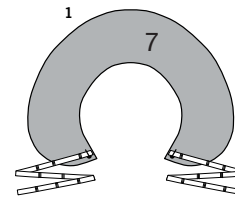
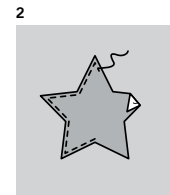

- Remove paper backing and center applique to front of purchased garment. Fuse in place following manufacturer's directions. Straight OR Zig-zag (satin) stitch along raw edges. OR use fabric paint to seal the edges. Allow paint to dry before you continue.

COLLAR D

- Cut two pieces of 3/8" (1cm) wide ribbon, each 12" (31cm) long. Pin ends of ribbon to neck edge of **COLLAR** (7) at large dots, having ends even with raw edges. Baste.
- Fuse **INTERFACING** to **WRONG** side of collar **LINING** following manufacturer's directions.
- Pin collar sections, **RIGHT** sides together. Stitch, using a 3/8" (1cm) seam, leaving an opening for turning, and avoiding catching in the free ends of ribbons. Trim corners. Clip curves.
- Turn right side out. Press. **SLIPSTITCH** opening.

SKIRT A, B, C, D

FRONT AND BACK AND ZIPPER

- STAYSTITCH** upper edge of **SKIRT FRONT AND BACK** (1).

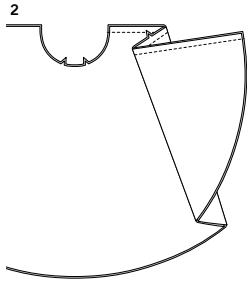

2. With RIGHT sides together, stitch skirt front and back sections at RIGHT side seam.

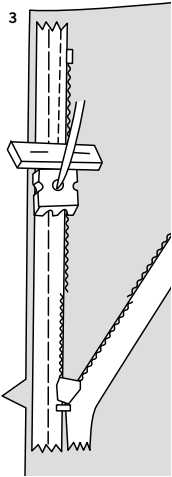

3. Open the zipper and press the tape using a cool iron. On OUTSIDE, pin RIGHT side of the zipper face down on the LEFT back of the side zipper opening. Have the coil along the seam line, the tape within the seam allowance and the top stop 3/4" (2cm) below upper edge, as shown. Hand-baste along center of the tape. Position zipper foot at the top of the zipper with RIGHT groove of the foot over coil. Stitch along tape to the notch. Back-stitch to reinforce.

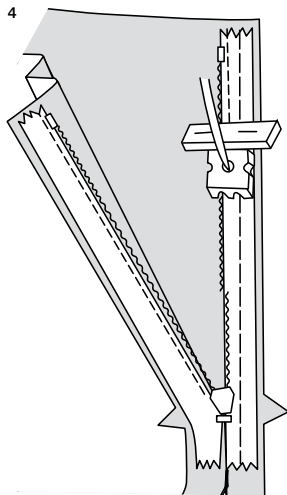

4. Pin the remaining half of the zipper to the LEFT front of the side zipper opening in same manner. Make sure the upper and lower edges of the garment are even. Hand-baste along the center of the tape. Position zipper foot at the top of the zipper with LEFT groove over the coil. Stitch along tape to the notch. Back-stitch to reinforce.

NOTE: Stitch the invisible zipper using an invisible zipper foot.

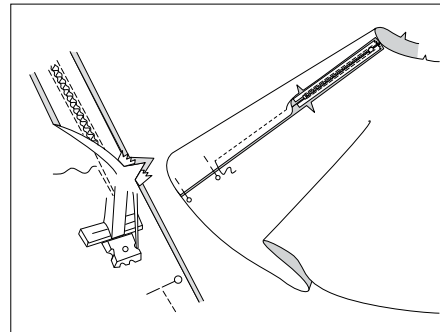

5. Close zipper and check that it is invisible from the OUTSIDE. Pull the free ends of the zipper tape away from the seam allowance. Pin remaining left side seam together below zipper. Position zipper foot all the way to the LEFT so the needle goes down through the outer notch of the foot. Start stitching seam 1/4" (6mm) above lowest stitch and slightly to the LEFT. Stitch seam for about 3" (7.5cm). Stitch remainder of seam using your regular presser foot.

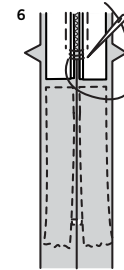

6. If the zipper is longer than the opening, using a strong thread, hand-sew a few small stitches across ends of coils at end of opening. Trim away lower end of zipper tape to within 5/8" (1.5cm) of hand-stitches.

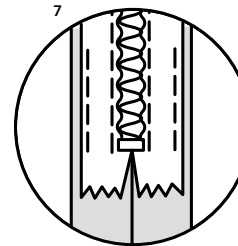

7. If you prefer, open out each seam allowance at end of zipper and stitch tape to seam allowance.

WAISTBAND



8. Fuse INTERFACING to WRONG side of WAISTBAND (3), following manufacturer's directions. Press under 5/8" (1.5cm) on long unnotched edge of band; trim to 3/8" (1cm).

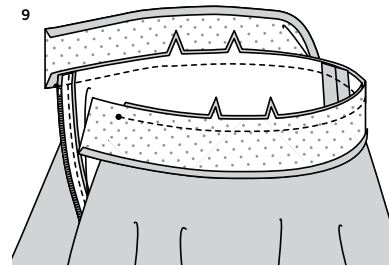

9. With RIGHT sides together, pin skirt to band, matching notches and centers, placing opening edges at outer small dots and RIGHT side seam at remaining small dot, clipping to staystitching as needed. Baste. Stitch. Trim seam; press toward band.

10

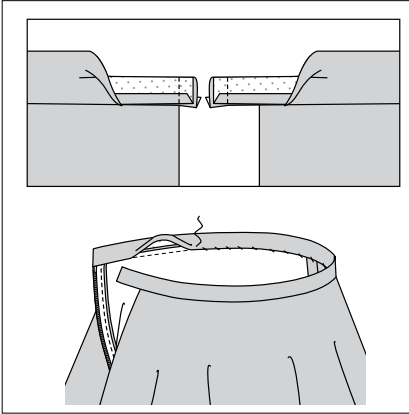

10. Fold band with **RIGHT** sides together. Stitch ends. Trim seams and corners. Turn **RIGHT** sides out. Press. **SLIPSTITCH** pressed edge of band over seam.

11

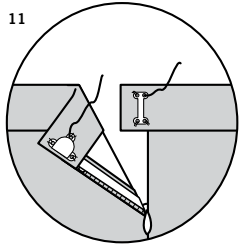

11. Lap ends of band; fasten with hook closure.

FINISHING

12

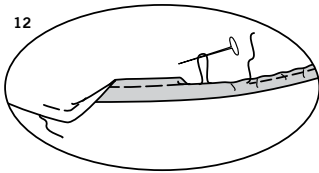

12. Make a 5/8" (1.5cm) **NARROW HEM** at lower edge of skirt.

13

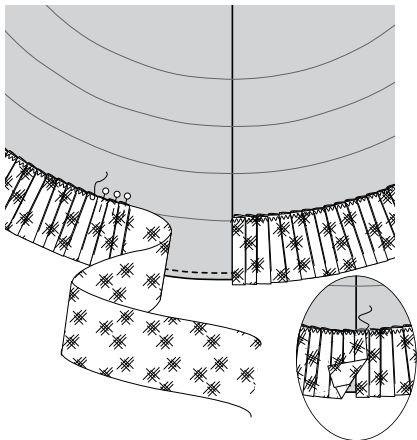

13. On **OUTSIDE**, starting at lowest ruffle placement line, make 1/2" (1.3cm) pleats in tulle trim while pinning upper edge 1/4" (6mm) above the placement line. Stitch in place with a zig-zag stitch along placement line, lapping ends at left side seam. Repeat for remaining rows of ruffles, lapping ends below zipper opening and ending at left front zipper opening.

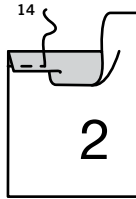

14. Make a 5/8" (1.5cm) **NARROW HEM** on upper edge of each **POCKET (2)** section.

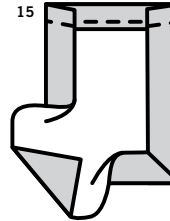

15. Press under 3/8" (1cm) on sides and lower edges of pocket.

16

ABC

D

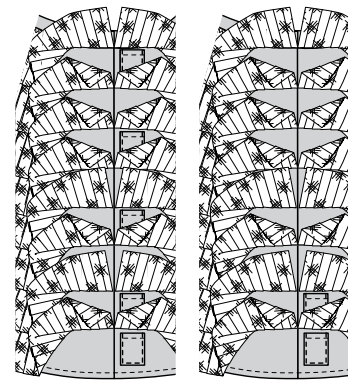

16. Lift ruffle. Pin pockets to **OUTSIDE** of back skirt along pocket lines at **LEFT** side seam. **EDGE**STITCH close to sides and lower edges of pocket, keeping ruffles free.

17

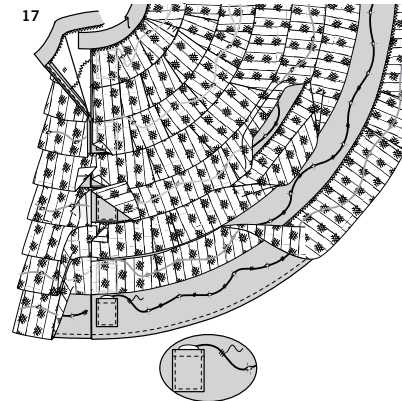

17. With battery pack for lights at left side seam, on **OUTSIDE**, arrange lights underneath ruffles, centering between placement lines; **TACK** wires securely to skirt. Slip battery pack into pockets. **VIEW D**: Only lower two ruffles have lights. **VIEW A**: Glue pompons to skirt as desired.



Congrats!

You've completed your sewing adventure

**SHARE
YOUR** LOOK



Post your pattern and tag us
@simplicity_creative_group and **#simplicitypatterns**
for a chance to be featured on our social media.

Look for more PDF patterns at [simplicity.com](https://www.simplicity.com)

Have a question or need help with your sewing project call us at
1-888-588-2700



Simplicity ©2023 a division of IG Design Group Americas Inc. • Atlanta, GA 30342 USA www.thedesigngroup.com • All Rights Reserved. www.simplicity.com • Made in the U.S.A. Fabriqué aux États-Unis.

To be used for individual private home use only and not for commercial or manufacturing purposes. • A usage privé seulement et non à des fins commerciales ou de production en série. • Para uso privado solamente, no se puede utilizar con propósitos de comercialización o de producción en serie.