

S9858

**Simplicity**



Designed and printed in USA.

easy-to-sew

Easy

**UNISEX SHIRTS**

**Suggested Fabrics:** Corduroy, Cotton Shirting, Faux Leather/Suede, Lightweight Denim, Linens, Rayons. **Interfacing:** Lightweight Fusible.

**Notions: A,B:** Eleven ½" (1.3cm) buttons.

Sizes	XS	S	M	L	XL	XXL
	30-32	34-36	38-40	42-44	46-48	50-52

**BODY MEASUREMENTS: Select pattern size based on body measurements**

	30-32	34-36	38-40	42-44	46-48	50-52	Ins.
<b>Chest</b>	30-32	34-36	38-40	42-44	46-48	50-52	Ins.
<b>Waist</b>	26-27	28-30	32-34	36-39	42-44	46-48	"
<b>Hip</b>	32-34	35-37	39-41	43-45	47-49	51-53	"

<b>Shirt A</b>	45**	2½	2½	2½	2½	2¾	2¾	Yds.
	60**	1¾	2	2	2½	2½	2½	"

**Interfacing** 20" - 1 yd.

<b>Shirt B</b>	45**	2¾	2¾	2¾	2¾	3	3	Yds.
	60**	2½	2½	2½	2½	2¾	2¾	"

**Interfacing** 20" - 1¾ yds.

**FINISHED GARMENT MEASUREMENTS (Includes Design and Wearing Ease)**

<b>A,B Bust/Chest</b>	40½	42½	46½	50½	54½	58½	Ins.
<b>A,B Waist</b>	38	40	44	48	52	56	"

**Finished back length from base of neck**

<b>Shirt A,B</b>	28½	29	29½	30	30½	31	Ins.
------------------	-----	----	-----	----	-----	----	------

\*with nap \*\*without nap

Facile

**CHEMISES UNISEXE**

**Tissus Conseillés:** Velours côtelé, Shirting de coton, Simili cuir/ Daim, Denim léger, Toiles de lin, Rayonnes. **Entoilage:** Thermocollant léger.

**Mercerie: A,B:** 11 boutons de 1.3cm.

Tailles	TP/XS	P/S	M	G/L	TG/XL	TTG/XXL
Fr/ Eur	40-42	44-46	48-50	52-54	56-58	60-62

**MESURES DU CORPS: Choisissez la taille du patron basée sur les mesures du corps**

	76-81	87-92	97-102	107-112	117-122	127-132	cm
<b>Poitrine</b>	76-81	87-92	97-102	107-112	117-122	127-132	cm
<b>Taille</b>	66-69	71-76	81-87	92-99	107-112	117-122	"
<b>Hanches</b>	82-87	89-94	99-104	109-115	119-124	128-135	"

<b>Chemise A</b>	115cm*	2.3	2.3	2.3	2.4	2.5	2.5	m
	150cm*	1.7	1.8	1.8	1.8	1.9	1.9	"

**Entoilage** 51cm - 0.9m

<b>Chemise B</b>	115cm*	2.5	2.5	2.5	2.6	2.7	2.7	m
	150cm*	1.8	1.9	1.9	1.9	2.1	2.1	"

**Entoilage** 51cm - 1.3m

**MESURES DES VÊTEMENTS FINI (Motif et aisance de port compris)**

<b>A,B Poitrine</b>	103	108	118	128	138	149	cm
<b>A,B Taille</b>	97	102	112	122	132	142	"

**Longueur finie – dos, votre nuque à l'ourlet**

<b>Chemise A,B</b>	72	74	75	76	77	79	cm
--------------------	----	----	----	----	----	----	----

\*avec sens \*\*sans sens



# Simplicity®

Thank you for purchasing this Simplicity pattern. We made every effort to provide you with a high quality product.

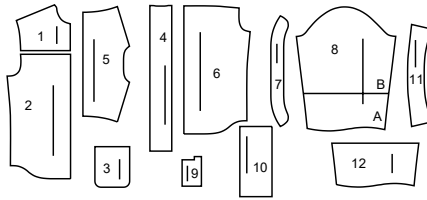
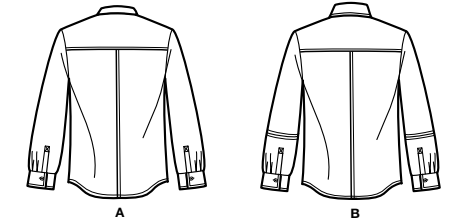
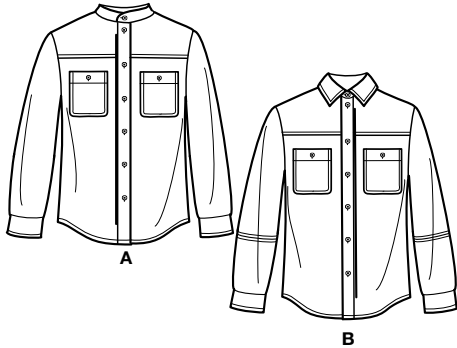

- 1 Yoke Front-A,B
- 2 Front-A,B
- 3 Pocket-A,B
- 4 Front Band-A,B
- 5 Yoke Back-A,B
- 6 Back-A,B
- 7 Collar Band-A,B
- 8 Sleeve-A,B
- 9 Placket-A,B
- 10 Cuff-A,B
- 11 Collar-B
- 12 Lower Sleeve-B

## General Directions

### The Pattern

- SYMBOLS**
- GRAIN LINE Place on straight grain of fabric parallel to selvage
  - PLACE SOLID LINE on fold of fabric.
  - CENTER FRONT OR BACK of garment.
  - NOTCHES
  - DOTS
  - CUTTING LINE
  - LENGTHEN OR SHORTEN LINES

SEAM ALLOWANCE: 5/8" (1.5cm) unless otherwise stated is included but not printed on MULTI-SIZE PATTERNS. Mark your size with colored felt tip pen. See chart on tissue for how to use MULTI-SIZE PATTERNS.

**ADJUST IF NEEDED**  
Make adjustments before placing pattern on fabric.

**TO LENGTHEN:**  
Cut pattern between lengthen or shorten lines. Spread pattern evenly, the amount needed and tape to paper.

**TO SHORTEN:**  
At lengthen or shorten lines, make an even pleat taking up amount needed. Tape in place.

When lengthen or shorten lines are not given, make adjustments at lower edge of pattern.

### Cutting/Marking

**BEFORE CUTTING:**  
PRESS pattern pieces with a warm dry iron. PRE-SHRINK fabric by pre-washing washables or steam-pressing non-washables.

CIRCLE your cutting layout.  
PIN pattern to fabric as shown in Cutting Layouts.

- FOR DOUBLE THICKNESS: Fold fabric with RIGHT sides together.
- FOR SINGLE THICKNESS: Place fabric RIGHT side up.
- FOR PILE, SHADED OR ONE WAY DESIGN FABRICS: Use "with nap" layouts

**AFTER CUTTING:**  
Transfer markings to WRONG side of fabric before removing pattern. Use pin and chalk method or dressmaker's tracing paper and wheel.

#### To Quick Mark:

- Snip edge of fabric to mark notches, ends of fold lines and center lines.
- Pin mark dots.

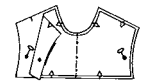

### Sewing

- SEW garment following Sewing Directions.
- PIN or machine-baste seams matching notches.
- STITCH 5/8" (1.5 cm) seams unless otherwise stated.
- PRESS seams open unless otherwise indicated clipping when necessary so seams will lie flat.
- TRIM seams to reduce bulk, as shown below.

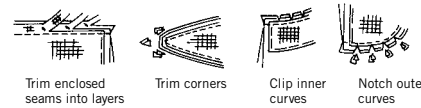

### SPECIAL CUTTING NOTES

★ If layout shows a piece extending past fold, cut out all pieces except piece that extends.

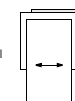

Open out fabric to single thickness. Cut extending piece on RIGHT side of fabric in position shown.

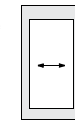

✱ Mark small arrows along both selvages indicating direction of nap or design. Fold fabric crosswise with RIGHT sides together, and cut along fold (a).

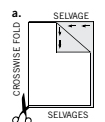

Turn one fabric layer around so arrows on both layers go in the same direction. Place RIGHT sides together (b).

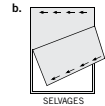

## Cutting Layouts

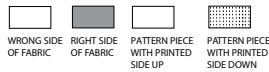

POSITION OF PATTERN PIECES MAY VARY SLIGHTLY ACCORDING TO YOUR PATTERN SIZE

### SHIRT A

USE PIECES 1 2 3 4 5 6 7 8 9 10

45" (115CM) WITH NAP ALL SIZES

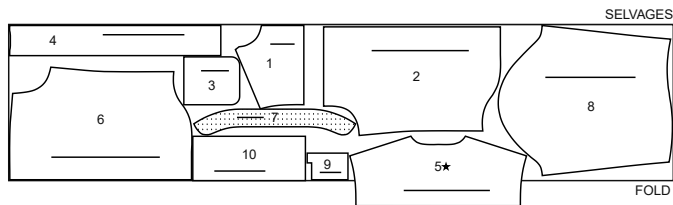

60" (150CM) WITH NAP ALL SIZES

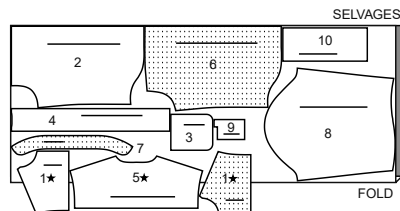

### INTERFACING A

USE PIECES 4 7 10

20" (51CM) ALL SIZES

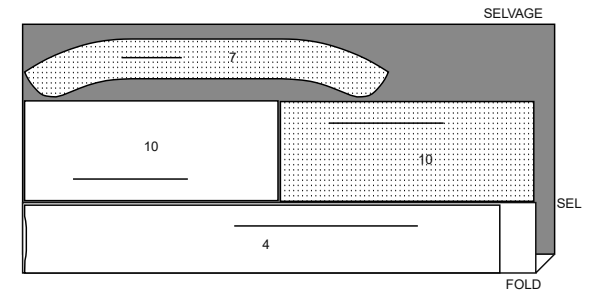

### SHIRT B

USE PIECES 1 2 3 4 5 6 7 8 9 10 11 12

45" (115CM) WITH NAP ALL SIZES

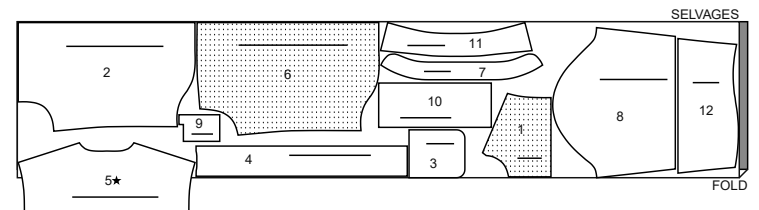

CUTTING LAYOUTS CONTINUED ON PAGE 2

60" (150CM)  
WITH NAP  
ALL SIZES

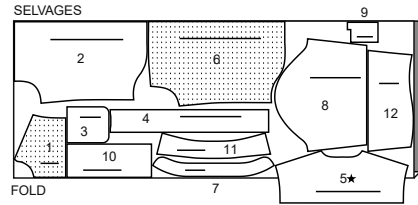

### INTERFACING B

USE PIECES 4 7 10 11

20" (51CM)  
ALL SIZES

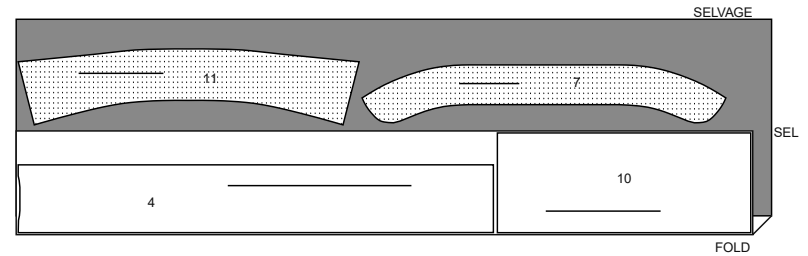

### SEWING TUTORIALS



Build your skills viewing short, easy-to-follow videos at  
[simplicity.com/sewingtutorials](http://simplicity.com/sewingtutorials)

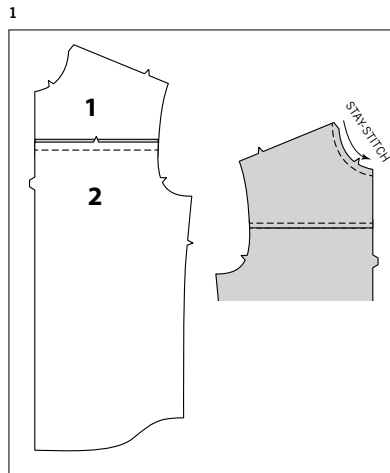

## Sewing Directions

FABRIC KEY **RIGHT SIDE** **WRONG SIDE** **INTERFACING** **LINING** **LINING**

Read **General Directions** on page 1 before you begin.

Sewing methods in **BOLD TYPE** have Sewing Tutorial Video available.  
Scan QR CODE to watch videos:

**EDGESTITCH** - See how to edgestitch video.

**NARROW HEM** - See sewing narrow hems video.

**STAYSTITCH** - See how to do stay-stitching video.

**TOPSTITCH** - See how to topstitch video.

**PATTERN PIECES WILL BE IDENTIFIED BY NUMBERS THE FIRST TIME THEY ARE USED.**

**STITCH SEAMS WITH RIGHT SIDES TOGETHER UNLESS OTHERWISE STATED.**

### SHIRT A, B

**NOTE:** View A will be shown unless otherwise indicated.

1. With **RIGHT** sides together, stitch yoke front (1) to front (2). Press seam up.  
On **OUTSIDE**, **TOPSTITCH** yoke front.  
**STAYSTITCH** neck edge of front.

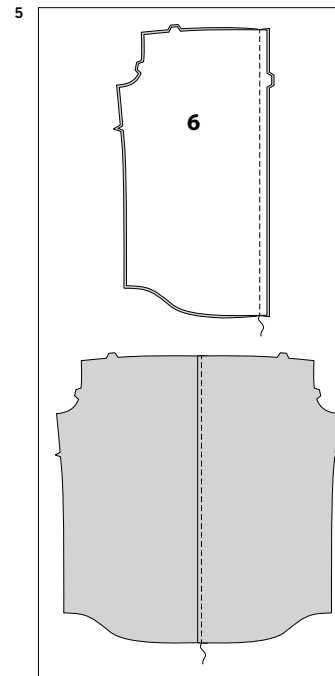
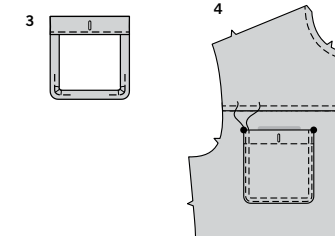
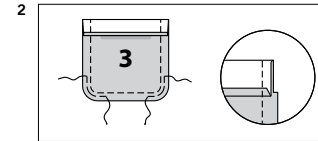

2. Press under 1/4" (6mm) on upper edge of pocket.  
Turn upper edge to **OUTSIDE** along fold line, forming facing.  
Stitch along seam line on raw edges. To ease curved edge of pocket, stitch 1/4" (6mm) **OUTSIDE** the seam line, using a long machine-stitch. Trim seam allowance in the facing area to 1/4" (6mm).
3. Turn corners **RIGHT** side out, turning facing to the **WRONG** side; press, pressing under raw edges along stitching. Pull up ease stitches to shape the curve. To eliminate bulk, notch out the fullness in the seam allowance along the curves as far as the ease stitches. Stitch facing close to inner edge.  
Make buttonhole in upper edge of pocket at marking.
4. On **OUTSIDE**, pin pocket to upper edge of front matching large dots.  
**EDGESTITCH** and **TOPSTITCH** pocket edges.
5. With **RIGHT** sides together, stitch center back seam of back (6) sections. Press seam toward **RIGHT** back.  
On **OUTSIDE**, **TOPSTITCH** **RIGHT** back, as shown.

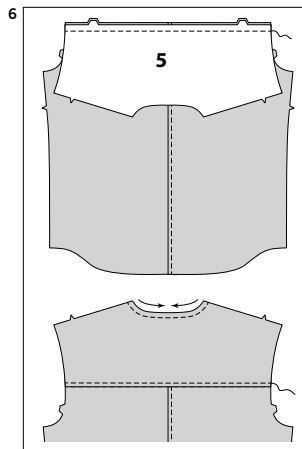

- 6.** Stitch yoke back (5) to upper edge of back, matching notches. Press seam up, pressing yoke out. On OUTSIDE, **TOPSTITCH** yoke back, as shown. **STAYSTITCH** neck edge of back.

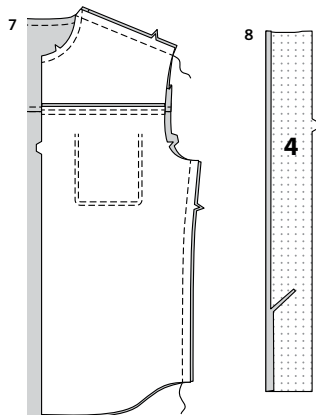

- 7.** With RIGHT sides together, stitch fronts to back at shoulder and side seams.

- 8.** Apply fusible interfacing to WRONG side of front band (4) sections following manufacturer's directions. Press under 5/8" (1.5cm) on unmarked edge. Trim to 1/4" (6mm).

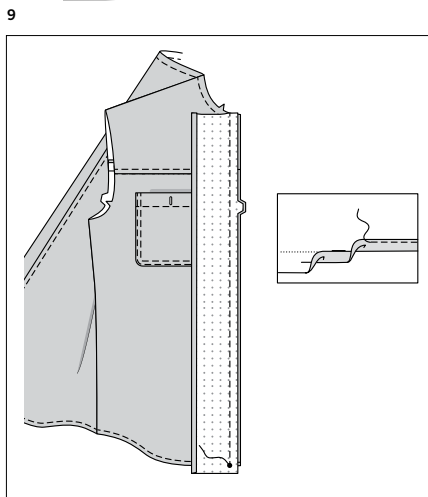

- 9. NARROW HEM** lower edge of garment, easing fullness if necessary. With RIGHT sides together pin band to front matching notches and lower small dots. Stitch.

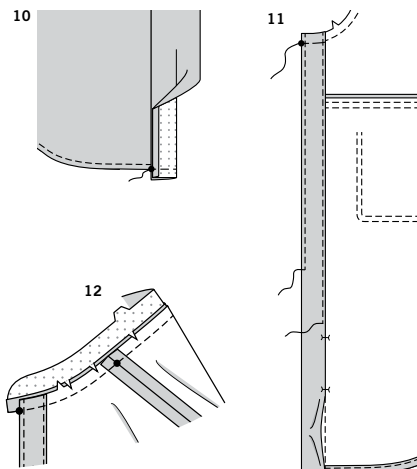

- 10.** Press seam toward band, pressing band out. Fold lower end of band, with RIGHT sides together, matching small dots, forming facing. Stitch ends in a 5/8" (1.5 cm) seam, being careful not to stitch lower end of shirt. Trim band below stitching.

- 11.** Turn band to INSIDE; press. Place pressed edge over seam. Pin in place, placing pins on OUTSIDE. On OUTSIDE, stitch close to seam of band, catching in pressed edge on INSIDE. Baste raw edges together. **EDGESTITCH** front edge of band.

- 12.** Apply fusible interfacing to WRONG side of one collar band (7) section. Fuse interfacing in place following manufacturer's directions. Clip garment neck edge to stay-stitching. With RIGHT sides together, pin single notched edge of band to neck edge, matching centers back and placing small dots at shoulder seams, matching remaining small dots. (Neckband extends 5/8" (1.5cm) beyond front opening edges.) Stitch neck edge. Trim seam; clip curves. Press band out; press seam toward band.

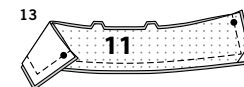

- 13. VIEW B-** Fuse interfacing to WRONG side of one collar (11) section following manufacturer's directions. With RIGHT sides together and raw edges even, stitch facing to collar, leaving notched edges open. Trim seam and corners.

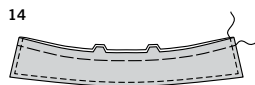

- 14.** Turn collar; press. Machine-baste raw edges together. **TOPSTITCH** outer edges of collar.

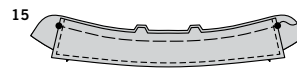

- 15.** With RIGHT sides together and raw edges even, pin collar (facing side) to collar band, matching centers back, notches and matching large dots at front. Machine-baste.

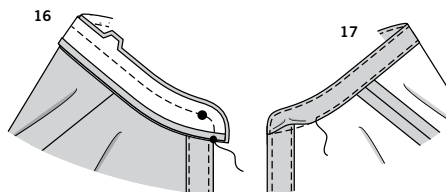

- 16. All VIEWS-** Press under 5/8" (1.5cm) on single notched edge of collar band facing; trim to 1/4" (6mm). With RIGHT sides together, pin neckband facing to neck band (over collar for View B), matching centers. Stitch front and double notched edge. Trim seam; clip curves.

- 17.** Turn band facing to INSIDE; press. Pin pressed edge of facing over seam, placing pins on OUTSIDE. On OUTSIDE, stitch close to all edges of neckband, catching in pressed edge of facing on INSIDE.

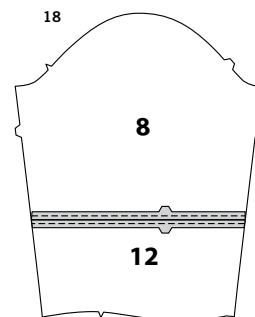

- 18. VIEW B-** With right sides together, stitch lower sleeve (12) to lower edge of sleeve (8) matching notches. Press seam open. On outside, **TOPSTITCH** each side of finished seam, as shown.

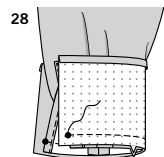
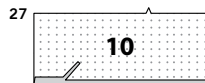
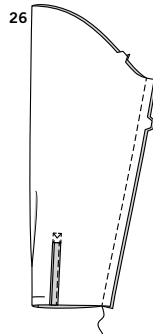
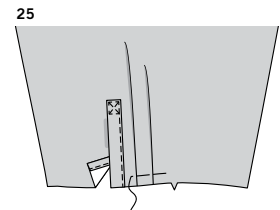
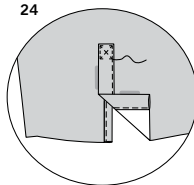
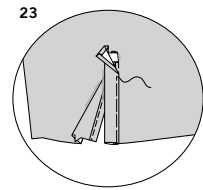
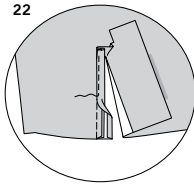
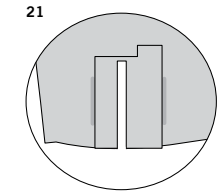
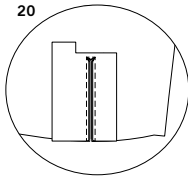
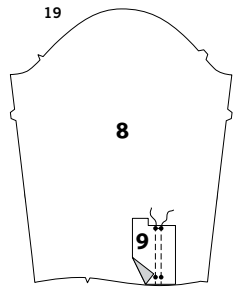

**19. All VIEWS-** Pin RIGHT side of placket (9) to WRONG side of sleeve (8), matching small dots, as shown. Stitch along stitching lines on sleeve placket, reinforcing stitching at small dots at upper edge.

**20.** Slash between stitching, clipping diagonally to small dots at upper edge, as shown.

**21.** Turn placket and clipped corners to OUTSIDE, pressing side seams toward opening and triangle towards sleeve.

**22.** Press under 1/4" (6mm) on long edge at left side of placket. Pin pressed edge over seam, pressing along foldline and forming underlap. Stitch close to pressed edge of underlap.

**23.** Press under 1/4" (6mm) on upper end and long edge of right half of placket. Fold right half of placket along fold line, forming overlap. Baste pressed edge of overlap over seam and sleeve, as shown.

**24.** Stitch close to basted edges of overlap and along stitching lines.

**25.** To make pleats, fold along solid lines. Bring folds to broken lines; pin. Baste across lower edge.

**26.** With RIGHT sides together, stitch under arm seam in sleeve sections.

**27.** Fuse interfacing to WRONG side of cuff (10) sections, following manufacturer's directions. Press under 5/8" (1.5cm) on unnotched edge of cuff. Trim to 1/4" (6mm).

**28.** With RIGHT sides together, pin sleeve to cuff, placing opening edges at small dots. Baste, easing sleeve edge to fit. Stitch. Trim seam.

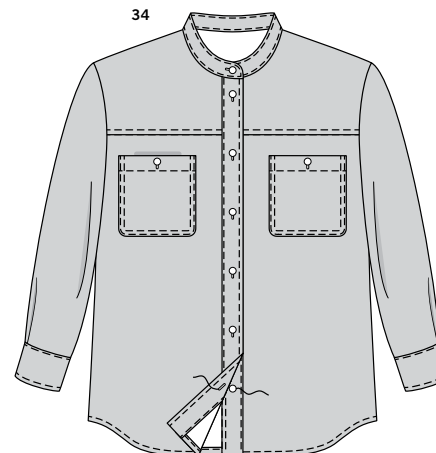
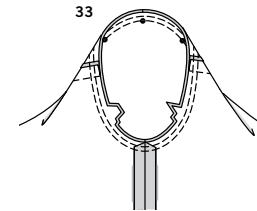
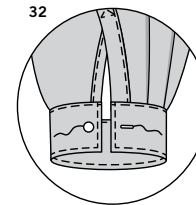
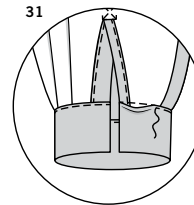
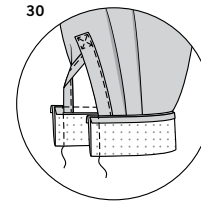
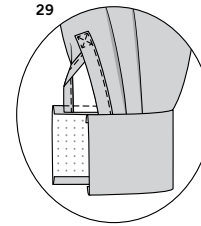

**29.** Press seam toward cuff, pressing cuff out.

**30.** Fold cuff along fold line, with RIGHT sides together. Stitch ends. Trim seams.

**31.** Turn cuff; press. On INSIDE, pin pressed edge of cuff over seam, placing pins on OUTSIDE. On OUTSIDE, top-stitch cuff close to seam, catching in pressed edge of cuff on INSIDE and removing pins as you come to them.

**32.** TOPSTITCH outer edges of cuff. Make buttonhole at markings. Sew button at small dot.

**33.** Turn sleeve RIGHT side out. Hold garment WRONG side out with armhole toward you. With RIGHT sides together, pin sleeve to armhole edge with center small dot at shoulder seam, matching underarm seams, notches and remaining small dots. Baste. Stitch. Stitch again 1/8" (3mm) from first stitching. Trim seam below notches close to stitching. Press only the seam allowance, shrinking out fullness.

**34. Note:** Illustrations will show RIGHT over LEFT construction. Make buttonholes in RIGHT or LEFT front and collar band at markings. Lap RIGHT over LEFT matching centers. Sew buttons to LEFT front under buttonholes. Hand-sew buttons to front (under pockets) at small dots.



# Congrats!

You've completed your sewing adventure

---

**SHARE  
YOUR** LOOK



Post your pattern and tag us  
**@simplicity\_creative\_group** and **#simplicitypatterns**  
for a chance to be featured on our social media.

Look for more PDF patterns at [simplicity.com](https://www.simplicity.com)

Have a question or need help with your sewing project call us at  
1-888-588-2700



Simplicity ©2023 a division of IG Design Group Americas Inc. • Atlanta, GA 30342 USA [www.thedesigngroup.com](https://www.thedesigngroup.com) • All Rights Reserved. [www.simplicity.com](https://www.simplicity.com) • Made in the U.S.A. Fabriqué aux États-Unis.

To be used for individual private home use only and not for commercial or manufacturing purposes. • A usage privé seulement et non à des fins commerciales ou de production en série. • Para uso privado solamente, no se puede utilizar con propósitos de comercialización o de producción en serie.