

S9822

**miG** A DIY & LIFESTYLE BRAND



Scan QR code for a Sew-Along tutorial by sewing celebrity Mimi G.

**Simplicity**



Average

**MISSES' JUMPSUITS**

**Suggested Fabrics:** Challis, Denim, Linen Types, Microfiber, Poplin, Sateen, Twill.

**Interfacing:** Lightweight Fusible.

**Notions:** A: Eleven 5/8" (1.5cm) heavy duty snaps. B: Eleven 5/8" (1.5cm) buttons.

|          |    |    |    |    |    |    |    |    |    |    |
|----------|----|----|----|----|----|----|----|----|----|----|
| Sizes    | 8  | 10 | 12 | 14 | 16 | 18 | 20 | 22 | 24 | 26 |
| European | 34 | 36 | 38 | 40 | 42 | 44 | 46 | 48 | 50 | 52 |

**BODY MEASUREMENTS: Select pattern size based on body measurements**

|                    |     |     |     |     |     |    |     |     |     |     |    |    |      |
|--------------------|-----|-----|-----|-----|-----|----|-----|-----|-----|-----|----|----|------|
| Bust               | 31½ | 32½ | 34  | 36  | 38  | 40 | 42  | 44  | 46  | 48  | 50 | 52 | Ins. |
| Waist              | 24  | 25  | 26½ | 28  | 30  | 32 | 34  | 37  | 39  | 41½ | "  |    |      |
| Hip-9" below waist | 33½ | 34½ | 36  | 38  | 40  | 42 | 44  | 46  | 48  | 50  | "  |    |      |
| Back-neck to waist | 15¾ | 16  | 16¼ | 16½ | 16¾ | 17 | 17¼ | 17½ | 17¾ | 18  | "  |    |      |

**Jumpsuit A**

|      |   |   |   |    |    |    |   |    |    |    |   |    |    |    |   |    |    |    |   |    |    |    |   |    |    |    |    |     |     |     |    |     |     |     |    |     |     |     |    |     |     |     |    |     |     |     |    |     |     |     |    |     |     |     |    |     |     |     |    |     |     |     |    |     |     |     |    |     |     |     |    |     |     |     |    |     |     |     |    |     |     |     |    |     |     |     |    |     |     |     |    |     |     |     |    |     |     |     |    |     |     |     |    |     |     |     |    |     |     |     |    |     |     |     |    |     |     |     |    |     |     |     |    |     |     |     |    |     |     |     |    |     |     |     |    |     |     |     |    |     |     |     |    |     |     |     |    |     |     |     |    |     |     |     |    |     |     |     |    |     |     |     |    |     |     |     |    |     |     |     |    |     |     |     |    |     |     |     |    |     |     |     |    |     |     |     |    |     |     |     |    |     |     |     |    |     |     |     |    |     |     |     |    |     |     |     |    |     |     |     |    |     |     |     |    |     |     |     |    |     |     |     |    |     |     |     |    |     |     |     |    |     |     |     |    |     |     |     |    |     |     |     |    |     |     |     |    |     |     |     |    |     |     |     |    |     |     |     |    |     |     |     |    |     |     |     |    |     |     |     |    |     |     |     |    |     |     |     |    |     |     |     |    |     |     |     |    |     |     |     |    |     |     |     |    |     |     |     |    |     |     |     |    |     |     |     |    |     |     |     |    |     |     |     |    |     |     |     |    |     |     |     |    |     |     |     |    |     |     |     |    |     |     |     |    |     |     |     |    |     |     |     |    |     |     |     |    |     |     |     |    |     |     |     |    |     |     |     |    |     |     |     |    |     |     |     |    |     |     |     |    |     |     |     |    |     |     |     |    |     |     |     |    |     |     |     |     |      |      |      |     |      |      |      |     |      |      |      |     |      |      |      |     |      |      |      |     |      |      |      |     |      |      |      |     |      |      |      |     |      |      |      |     |      |      |      |     |      |      |      |     |      |      |      |     |      |      |      |     |      |      |      |     |      |      |      |     |      |      |      |     |      |      |      |     |      |      |      |     |      |      |      |     |      |      |      |     |      |      |      |     |      |      |      |     |      |      |      |     |      |      |      |     |      |      |      |     |      |      |      |     |      |      |      |     |      |      |      |     |      |      |      |     |      |      |      |     |      |      |      |     |      |      |      |     |      |      |      |     |      |      |      |     |      |      |      |     |      |      |      |     |      |      |      |     |      |      |      |     |      |      |      |     |      |      |      |     |      |      |      |     |      |      |      |     |      |      |      |     |      |      |      |     |      |      |      |     |      |      |      |     |      |      |      |     |      |      |      |     |      |      |      |     |      |      |      |     |      |      |      |     |      |      |      |     |      |      |      |     |      |      |      |     |      |      |      |     |      |      |      |     |      |      |      |     |      |      |      |     |      |      |      |     |      |      |      |     |      |      |      |     |      |      |      |     |      |      |      |     |      |      |      |     |      |      |      |     |      |      |      |     |      |      |      |     |      |      |      |     |      |      |      |     |      |      |      |     |      |      |      |     |      |      |      |     |      |      |      |     |      |      |      |     |      |      |      |     |      |      |      |     |      |      |      |     |      |      |      |     |      |      |      |     |      |      |      |     |      |      |      |     |      |      |      |     |      |      |      |     |      |      |      |     |      |      |      |     |      |      |      |     |      |      |      |     |      |      |      |     |      |      |      |     |      |      |      |     |      |      |      |     |      |      |      |     |      |      |      |     |      |      |      |     |      |      |      |     |      |      |      |     |      |      |      |     |      |      |      |     |      |      |      |     |      |      |      |     |      |      |      |     |      |      |      |     |      |      |      |     |      |      |      |     |      |      |      |     |      |      |      |     |      |      |      |     |      |      |      |     |      |      |      |     |      |      |      |     |      |      |      |     |      |      |      |     |      |      |      |     |      |      |      |     |      |      |      |     |      |      |      |     |      |      |      |     |      |      |      |     |      |      |      |     |      |      |      |     |      |      |      |     |      |      |      |     |      |      |      |     |      |      |      |     |      |      |      |     |      |      |      |     |      |      |      |     |      |      |      |     |      |      |      |     |      |      |      |     |      |      |      |     |      |      |      |     |      |      |      |     |      |      |      |     |      |      |      |     |      |      |      |     |      |      |      |     |      |      |      |     |      |      |      |     |      |      |      |     |      |      |      |     |      |      |      |     |      |      |      |     |      |      |      |     |      |      |      |     |      |      |      |     |      |      |      |     |      |      |      |     |      |      |      |     |      |      |      |     |      |      |      |     |      |      |      |     |      |      |      |     |      |      |      |     |      |      |      |     |      |      |      |     |      |      |      |     |      |      |      |     |      |      |      |     |      |      |      |     |      |      |      |     |      |      |      |     |      |      |      |     |      |      |      |     |      |      |      |     |      |      |      |     |      |      |      |     |      |      |      |     |      |      |      |     |      |      |      |     |      |      |      |     |      |      |      |     |      |      |      |     |      |      |      |     |      |      |      |     |      |      |      |     |      |      |      |     |      |      |      |     |      |      |      |     |      |      |      |     |      |      |      |     |      |      |      |     |      |      |      |     |      |      |      |     |      |      |      |     |      |      |      |     |      |      |      |     |      |      |      |     |      |      |      |     |      |      |      |     |      |      |      |    |
|------|---|---|---|----|----|----|---|----|----|----|---|----|----|----|---|----|----|----|---|----|----|----|---|----|----|----|----|-----|-----|-----|----|-----|-----|-----|----|-----|-----|-----|----|-----|-----|-----|----|-----|-----|-----|----|-----|-----|-----|----|-----|-----|-----|----|-----|-----|-----|----|-----|-----|-----|----|-----|-----|-----|----|-----|-----|-----|----|-----|-----|-----|----|-----|-----|-----|----|-----|-----|-----|----|-----|-----|-----|----|-----|-----|-----|----|-----|-----|-----|----|-----|-----|-----|----|-----|-----|-----|----|-----|-----|-----|----|-----|-----|-----|----|-----|-----|-----|----|-----|-----|-----|----|-----|-----|-----|----|-----|-----|-----|----|-----|-----|-----|----|-----|-----|-----|----|-----|-----|-----|----|-----|-----|-----|----|-----|-----|-----|----|-----|-----|-----|----|-----|-----|-----|----|-----|-----|-----|----|-----|-----|-----|----|-----|-----|-----|----|-----|-----|-----|----|-----|-----|-----|----|-----|-----|-----|----|-----|-----|-----|----|-----|-----|-----|----|-----|-----|-----|----|-----|-----|-----|----|-----|-----|-----|----|-----|-----|-----|----|-----|-----|-----|----|-----|-----|-----|----|-----|-----|-----|----|-----|-----|-----|----|-----|-----|-----|----|-----|-----|-----|----|-----|-----|-----|----|-----|-----|-----|----|-----|-----|-----|----|-----|-----|-----|----|-----|-----|-----|----|-----|-----|-----|----|-----|-----|-----|----|-----|-----|-----|----|-----|-----|-----|----|-----|-----|-----|----|-----|-----|-----|----|-----|-----|-----|----|-----|-----|-----|----|-----|-----|-----|----|-----|-----|-----|----|-----|-----|-----|----|-----|-----|-----|----|-----|-----|-----|----|-----|-----|-----|----|-----|-----|-----|----|-----|-----|-----|----|-----|-----|-----|----|-----|-----|-----|----|-----|-----|-----|----|-----|-----|-----|----|-----|-----|-----|----|-----|-----|-----|----|-----|-----|-----|----|-----|-----|-----|----|-----|-----|-----|----|-----|-----|-----|----|-----|-----|-----|----|-----|-----|-----|----|-----|-----|-----|----|-----|-----|-----|----|-----|-----|-----|----|-----|-----|-----|----|-----|-----|-----|----|-----|-----|-----|----|-----|-----|-----|-----|------|------|------|-----|------|------|------|-----|------|------|------|-----|------|------|------|-----|------|------|------|-----|------|------|------|-----|------|------|------|-----|------|------|------|-----|------|------|------|-----|------|------|------|-----|------|------|------|-----|------|------|------|-----|------|------|------|-----|------|------|------|-----|------|------|------|-----|------|------|------|-----|------|------|------|-----|------|------|------|-----|------|------|------|-----|------|------|------|-----|------|------|------|-----|------|------|------|-----|------|------|------|-----|------|------|------|-----|------|------|------|-----|------|------|------|-----|------|------|------|-----|------|------|------|-----|------|------|------|-----|------|------|------|-----|------|------|------|-----|------|------|------|-----|------|------|------|-----|------|------|------|-----|------|------|------|-----|------|------|------|-----|------|------|------|-----|------|------|------|-----|------|------|------|-----|------|------|------|-----|------|------|------|-----|------|------|------|-----|------|------|------|-----|------|------|------|-----|------|------|------|-----|------|------|------|-----|------|------|------|-----|------|------|------|-----|------|------|------|-----|------|------|------|-----|------|------|------|-----|------|------|------|-----|------|------|------|-----|------|------|------|-----|------|------|------|-----|------|------|------|-----|------|------|------|-----|------|------|------|-----|------|------|------|-----|------|------|------|-----|------|------|------|-----|------|------|------|-----|------|------|------|-----|------|------|------|-----|------|------|------|-----|------|------|------|-----|------|------|------|-----|------|------|------|-----|------|------|------|-----|------|------|------|-----|------|------|------|-----|------|------|------|-----|------|------|------|-----|------|------|------|-----|------|------|------|-----|------|------|------|-----|------|------|------|-----|------|------|------|-----|------|------|------|-----|------|------|------|-----|------|------|------|-----|------|------|------|-----|------|------|------|-----|------|------|------|-----|------|------|------|-----|------|------|------|-----|------|------|------|-----|------|------|------|-----|------|------|------|-----|------|------|------|-----|------|------|------|-----|------|------|------|-----|------|------|------|-----|------|------|------|-----|------|------|------|-----|------|------|------|-----|------|------|------|-----|------|------|------|-----|------|------|------|-----|------|------|------|-----|------|------|------|-----|------|------|------|-----|------|------|------|-----|------|------|------|-----|------|------|------|-----|------|------|------|-----|------|------|------|-----|------|------|------|-----|------|------|------|-----|------|------|------|-----|------|------|------|-----|------|------|------|-----|------|------|------|-----|------|------|------|-----|------|------|------|-----|------|------|------|-----|------|------|------|-----|------|------|------|-----|------|------|------|-----|------|------|------|-----|------|------|------|-----|------|------|------|-----|------|------|------|-----|------|------|------|-----|------|------|------|-----|------|------|------|-----|------|------|------|-----|------|------|------|-----|------|------|------|-----|------|------|------|-----|------|------|------|-----|------|------|------|-----|------|------|------|-----|------|------|------|-----|------|------|------|-----|------|------|------|-----|------|------|------|-----|------|------|------|-----|------|------|------|-----|------|------|------|-----|------|------|------|-----|------|------|------|-----|------|------|------|-----|------|------|------|-----|------|------|------|-----|------|------|------|-----|------|------|------|-----|------|------|------|-----|------|------|------|-----|------|------|------|-----|------|------|------|-----|------|------|------|-----|------|------|------|-----|------|------|------|-----|------|------|------|-----|------|------|------|-----|------|------|------|-----|------|------|------|-----|------|------|------|-----|------|------|------|-----|------|------|------|-----|------|------|------|-----|------|------|------|-----|------|------|------|-----|------|------|------|-----|------|------|------|-----|------|------|------|-----|------|------|------|-----|------|------|------|-----|------|------|------|-----|------|------|------|-----|------|------|------|-----|------|------|------|-----|------|------|------|-----|------|------|------|-----|------|------|------|-----|------|------|------|-----|------|------|------|-----|------|------|------|-----|------|------|------|-----|------|------|------|-----|------|------|------|-----|------|------|------|-----|------|------|------|-----|------|------|------|-----|------|------|------|-----|------|------|------|-----|------|------|------|-----|------|------|------|-----|------|------|------|-----|------|------|------|----|
| 45** | 4 | 4 | 4 | 4¼ | 4½ | 4¾ | 5 | 5¼ | 5½ | 5¾ | 6 | 6¼ | 6½ | 6¾ | 7 | 7¼ | 7½ | 7¾ | 8 | 8¼ | 8½ | 8¾ | 9 | 9¼ | 9½ | 9¾ | 10 | 10¼ | 10½ | 10¾ | 11 | 11¼ | 11½ | 11¾ | 12 | 12¼ | 12½ | 12¾ | 13 | 13¼ | 13½ | 13¾ | 14 | 14¼ | 14½ | 14¾ | 15 | 15¼ | 15½ | 15¾ | 16 | 16¼ | 16½ | 16¾ | 17 | 17¼ | 17½ | 17¾ | 18 | 18¼ | 18½ | 18¾ | 19 | 19¼ | 19½ | 19¾ | 20 | 20¼ | 20½ | 20¾ | 21 | 21¼ | 21½ | 21¾ | 22 | 22¼ | 22½ | 22¾ | 23 | 23¼ | 23½ | 23¾ | 24 | 24¼ | 24½ | 24¾ | 25 | 25¼ | 25½ | 25¾ | 26 | 26¼ | 26½ | 26¾ | 27 | 27¼ | 27½ | 27¾ | 28 | 28¼ | 28½ | 28¾ | 29 | 29¼ | 29½ | 29¾ | 30 | 30¼ | 30½ | 30¾ | 31 | 31¼ | 31½ | 31¾ | 32 | 32¼ | 32½ | 32¾ | 33 | 33¼ | 33½ | 33¾ | 34 | 34¼ | 34½ | 34¾ | 35 | 35¼ | 35½ | 35¾ | 36 | 36¼ | 36½ | 36¾ | 37 | 37¼ | 37½ | 37¾ | 38 | 38¼ | 38½ | 38¾ | 39 | 39¼ | 39½ | 39¾ | 40 | 40¼ | 40½ | 40¾ | 41 | 41¼ | 41½ | 41¾ | 42 | 42¼ | 42½ | 42¾ | 43 | 43¼ | 43½ | 43¾ | 44 | 44¼ | 44½ | 44¾ | 45 | 45¼ | 45½ | 45¾ | 46 | 46¼ | 46½ | 46¾ | 47 | 47¼ | 47½ | 47¾ | 48 | 48¼ | 48½ | 48¾ | 49 | 49¼ | 49½ | 49¾ | 50 | 50¼ | 50½ | 50¾ | 51 | 51¼ | 51½ | 51¾ | 52 | 52¼ | 52½ | 52¾ | 53 | 53¼ | 53½ | 53¾ | 54 | 54¼ | 54½ | 54¾ | 55 | 55¼ | 55½ | 55¾ | 56 | 56¼ | 56½ | 56¾ | 57 | 57¼ | 57½ | 57¾ | 58 | 58¼ | 58½ | 58¾ | 59 | 59¼ | 59½ | 59¾ | 60 | 60¼ | 60½ | 60¾ | 61 | 61¼ | 61½ | 61¾ | 62 | 62¼ | 62½ | 62¾ | 63 | 63¼ | 63½ | 63¾ | 64 | 64¼ | 64½ | 64¾ | 65 | 65¼ | 65½ | 65¾ | 66 | 66¼ | 66½ | 66¾ | 67 | 67¼ | 67½ | 67¾ | 68 | 68¼ | 68½ | 68¾ | 69 | 69¼ | 69½ | 69¾ | 70 | 70¼ | 70½ | 70¾ | 71 | 71¼ | 71½ | 71¾ | 72 | 72¼ | 72½ | 72¾ | 73 | 73¼ | 73½ | 73¾ | 74 | 74¼ | 74½ | 74¾ | 75 | 75¼ | 75½ | 75¾ | 76 | 76¼ | 76½ | 76¾ | 77 | 77¼ | 77½ | 77¾ | 78 | 78¼ | 78½ | 78¾ | 79 | 79¼ | 79½ | 79¾ | 80 | 80¼ | 80½ | 80¾ | 81 | 81¼ | 81½ | 81¾ | 82 | 82¼ | 82½ | 82¾ | 83 | 83¼ | 83½ | 83¾ | 84 | 84¼ | 84½ | 84¾ | 85 | 85¼ | 85½ | 85¾ | 86 | 86¼ | 86½ | 86¾ | 87 | 87¼ | 87½ | 87¾ | 88 | 88¼ | 88½ | 88¾ | 89 | 89¼ | 89½ | 89¾ | 90 | 90¼ | 90½ | 90¾ | 91 | 91¼ | 91½ | 91¾ | 92 | 92¼ | 92½ | 92¾ | 93 | 93¼ | 93½ | 93¾ | 94 | 94¼ | 94½ | 94¾ | 95 | 95¼ | 95½ | 95¾ | 96 | 96¼ | 96½ | 96¾ | 97 | 97¼ | 97½ | 97¾ | 98 | 98¼ | 98½ | 98¾ | 99 | 99¼ | 99½ | 99¾ | 100 | 100¼ | 100½ | 100¾ | 101 | 101¼ | 101½ | 101¾ | 102 | 102¼ | 102½ | 102¾ | 103 | 103¼ | 103½ | 103¾ | 104 | 104¼ | 104½ | 104¾ | 105 | 105¼ | 105½ | 105¾ | 106 | 106¼ | 106½ | 106¾ | 107 | 107¼ | 107½ | 107¾ | 108 | 108¼ | 108½ | 108¾ | 109 | 109¼ | 109½ | 109¾ | 110 | 110¼ | 110½ | 110¾ | 111 | 111¼ | 111½ | 111¾ | 112 | 112¼ | 112½ | 112¾ | 113 | 113¼ | 113½ | 113¾ | 114 | 114¼ | 114½ | 114¾ | 115 | 115¼ | 115½ | 115¾ | 116 | 116¼ | 116½ | 116¾ | 117 | 117¼ | 117½ | 117¾ | 118 | 118¼ | 118½ | 118¾ | 119 | 119¼ | 119½ | 119¾ | 120 | 120¼ | 120½ | 120¾ | 121 | 121¼ | 121½ | 121¾ | 122 | 122¼ | 122½ | 122¾ | 123 | 123¼ | 123½ | 123¾ | 124 | 124¼ | 124½ | 124¾ | 125 | 125¼ | 125½ | 125¾ | 126 | 126¼ | 126½ | 126¾ | 127 | 127¼ | 127½ | 127¾ | 128 | 128¼ | 128½ | 128¾ | 129 | 129¼ | 129½ | 129¾ | 130 | 130¼ | 130½ | 130¾ | 131 | 131¼ | 131½ | 131¾ | 132 | 132¼ | 132½ | 132¾ | 133 | 133¼ | 133½ | 133¾ | 134 | 134¼ | 134½ | 134¾ | 135 | 135¼ | 135½ | 135¾ | 136 | 136¼ | 136½ | 136¾ | 137 | 137¼ | 137½ | 137¾ | 138 | 138¼ | 138½ | 138¾ | 139 | 139¼ | 139½ | 139¾ | 140 | 140¼ | 140½ | 140¾ | 141 | 141¼ | 141½ | 141¾ | 142 | 142¼ | 142½ | 142¾ | 143 | 143¼ | 143½ | 143¾ | 144 | 144¼ | 144½ | 144¾ | 145 | 145¼ | 145½ | 145¾ | 146 | 146¼ | 146½ | 146¾ | 147 | 147¼ | 147½ | 147¾ | 148 | 148¼ | 148½ | 148¾ | 149 | 149¼ | 149½ | 149¾ | 150 | 150¼ | 150½ | 150¾ | 151 | 151¼ | 151½ | 151¾ | 152 | 152¼ | 152½ | 152¾ | 153 | 153¼ | 153½ | 153¾ | 154 | 154¼ | 154½ | 154¾ | 155 | 155¼ | 155½ | 155¾ | 156 | 156¼ | 156½ | 156¾ | 157 | 157¼ | 157½ | 157¾ | 158 | 158¼ | 158½ | 158¾ | 159 | 159¼ | 159½ | 159¾ | 160 | 160¼ | 160½ | 160¾ | 161 | 161¼ | 161½ | 161¾ | 162 | 162¼ | 162½ | 162¾ | 163 | 163¼ | 163½ | 163¾ | 164 | 164¼ | 164½ | 164¾ | 165 | 165¼ | 165½ | 165¾ | 166 | 166¼ | 166½ | 166¾ | 167 | 167¼ | 167½ | 167¾ | 168 | 168¼ | 168½ | 168¾ | 169 | 169¼ | 169½ | 169¾ | 170 | 170¼ | 170½ | 170¾ | 171 | 171¼ | 171½ | 171¾ | 172 | 172¼ | 172½ | 172¾ | 173 | 173¼ | 173½ | 173¾ | 174 | 174¼ | 174½ | 174¾ | 175 | 175¼ | 175½ | 175¾ | 176 | 176¼ | 176½ | 176¾ | 177 | 177¼ | 177½ | 177¾ | 178 | 178¼ | 178½ | 178¾ | 179 | 179¼ | 179½ | 179¾ | 180 | 180¼ | 180½ | 180¾ | 181 | 181¼ | 181½ | 181¾ | 182 | 182¼ | 182½ | 182¾ | 183 | 183¼ | 183½ | 183¾ | 184 | 184¼ | 184½ | 184¾ | 185 | 185¼ | 185½ | 185¾ | 186 | 186¼ | 186½ | 186¾ | 187 | 187¼ | 187½ | 187¾ | 188 | 188¼ | 188½ | 188¾ | 189 | 189¼ | 189½ | 189¾ | 190 | 190¼ | 190½ | 190¾ | 191 | 191¼ | 191½ | 191¾ | 192 | 192¼ | 192½ | 192¾ | 193 | 193¼ | 193½ | 193¾ | 194 | 194¼ | 194½ | 194¾ | 195 | 195¼ | 195½ | 195¾ | 196 | 196¼ | 196½ | 196¾ | 197 | 197¼ | 197½ | 197¾ | 198 | 198¼ | 198½ | 198¾ | 199 | 199¼ | 199½ | 199¾ | 200 | 200¼ | 200½ | 200¾ | 201 | 201¼ | 201½ | 201¾ | 202 | 202¼ | 202½ | 202¾ | 203 | 203¼ | 203½ | 203¾ | 204 | 204¼ | 204½ | 204¾ | 205 | 205¼ | 205½ | 205¾ | 206 | 206¼ | 206½ | 206¾ | 207 | 207¼ | 207½ | 207¾ | 208 | 208¼ | 208½ | 208¾ | 209 | 209¼ | 209½ | 209¾ | 210 | 210¼ | 210½ | 210¾ | 211 | 211¼ | 211½ | 211¾ | 212 | 212¼ | 212½ | 212¾ | 213 | 213¼ | 213½ | 213¾ | 214 | 214¼ | 214½ | 214¾ | 215 | 215¼ | 215½ | 215¾ | 216 | 216¼ | 216½ | 216¾ | 217 | 217¼ | 217½ | 217¾ | 218 | 218¼ | 218½ | 218¾ | 219 | 219¼ | 219½ | 219¾ | 220 | 220¼ | 220½ | 220¾ | 221 | 221¼ | 221½ | 221¾ | 222 | 222¼ | 222½ | 222¾ | 223 | 223¼ | 223½ | 223¾ | 224 | 224¼ | 224½ | 224¾ | 225 | 225¼ | 225½ | 225¾ | 226 | 226¼ | 226½ | 226¾ | 227 | 227¼ | 227½ | 227¾ | 228 | 228¼ | 228½ | 228¾ | 229 | 229¼ | 229½ | 229¾ | 230 | 230¼ | 230½ | 230¾ | 231 | 231¼ | 231½ | 231¾ | 232 | 232¼ | 232½ | 232¾ | 233 | 233¼ | 233½ | 233¾ | 234 | 234¼ | 234½ | 234¾ | 235 | 235¼ | 235½ | 235¾ | 236 | 236¼ | 236½ | 236¾ | 237 | 237¼ | 237½ | 237¾ | 238 | 238¼ | 238½ | 238¾ | 239 | 239¼ | 239½ | 239¾ | 240 | 240¼ | 240½ | 240¾ | 241 | 241¼ | 241½ | 241¾ | 242 | 242¼ | 242½ | 242¾ | 243 | 243¼ | 243½ | 243¾ | 244 | 244¼ | 244½ | 244¾ | 245 | 245¼ | 245½ | 245¾ | 246 | 246¼ | 246½ | 246¾ | 247 | 247¼ | 247½ | 247¾ | 248 | 248¼ | 248½ | 248¾ | 249 | 249¼ | 249½ | 249¾ | 250 | 250¼ | 250½ | 250¾ | 251 | 251¼ | 251½ | 251¾ | 252 | 252¼ | 252½ | 252¾ | 253 | 253¼ | 253½ | 253¾ | 254 | 254¼ | 254½ | 254¾ | 255 | 255¼ | 255½ | 255¾ | 256 | 256¼ | 256½ | 256¾ | 257 | 257¼ | 257½ | 257¾ | 258 | 258¼ | 258½ | 258¾ | 259 | 259¼ | 259½ | 259¾ | 260 | 260¼ | 260½ | 260¾ | 261 | 261¼ | 261½ | 261¾ | 262 | 262¼ | 262½ | 262¾ | 263 | 263¼ | 263½ | 263¾ | 264 | 264¼ | 264½ | 264¾ | 265 | 265¼ | 265½ | 265¾ | 266 | 266¼ | 266½ | 266¾ | 267 | 267¼ | 267½ | 267¾ | 268 | 268¼ | 268½ | 268¾ | 269 | 269¼ | 269½ | 269¾ | 270 | 270¼ | 270½ | 270¾ | 271 | 271¼ | 271½ | 271¾ | 272 | 272¼ | 272½ | 272¾ | 273 | 273¼ | 273½ | 273¾ | 274 | 274¼ | 274½ | 274¾ | 275 | 275¼ | 275½ | 275¾ | 276 | 276¼ | 276½ | 276¾ | 277 | 277¼ | 277½ | 277¾ | 278 | 278¼ | 278½ | 278¾ | 279 | 279¼ | 279½ | 279¾ | 280 | 280¼ | 280½ | 280¾ | 281 | 281¼ | 281½ | 281¾ | 282 | 282¼ | 282½ | 282¾ | 283 | 283¼ | 283½ | 283¾ | 284 | 284¼ | 284½ | 284¾ | 285 | 285¼ | 285½ | 285¾ | 286 | 286¼ | 286½ | 286¾ | 287 | 287¼ | 287½ | 287¾ | 288 | 288¼ | 288½ | 288¾ | 289 | 289¼ | 289½ | 289¾ | 290 | 290¼ | 290½ | 290¾ | 29 |
|------|---|---|---|----|----|----|---|----|----|----|---|----|----|----|---|----|----|----|---|----|----|----|---|----|----|----|----|-----|-----|-----|----|-----|-----|-----|----|-----|-----|-----|----|-----|-----|-----|----|-----|-----|-----|----|-----|-----|-----|----|-----|-----|-----|----|-----|-----|-----|----|-----|-----|-----|----|-----|-----|-----|----|-----|-----|-----|----|-----|-----|-----|----|-----|-----|-----|----|-----|-----|-----|----|-----|-----|-----|----|-----|-----|-----|----|-----|-----|-----|----|-----|-----|-----|----|-----|-----|-----|----|-----|-----|-----|----|-----|-----|-----|----|-----|-----|-----|----|-----|-----|-----|----|-----|-----|-----|----|-----|-----|-----|----|-----|-----|-----|----|-----|-----|-----|----|-----|-----|-----|----|-----|-----|-----|----|-----|-----|-----|----|-----|-----|-----|----|-----|-----|-----|----|-----|-----|-----|----|-----|-----|-----|----|-----|-----|-----|----|-----|-----|-----|----|-----|-----|-----|----|-----|-----|-----|----|-----|-----|-----|----|-----|-----|-----|----|-----|-----|-----|----|-----|-----|-----|----|-----|-----|-----|----|-----|-----|-----|----|-----|-----|-----|----|-----|-----|-----|----|-----|-----|-----|----|-----|-----|-----|----|-----|-----|-----|----|-----|-----|-----|----|-----|-----|-----|----|-----|-----|-----|----|-----|-----|-----|----|-----|-----|-----|----|-----|-----|-----|----|-----|-----|-----|----|-----|-----|-----|----|-----|-----|-----|----|-----|-----|-----|----|-----|-----|-----|----|-----|-----|-----|----|-----|-----|-----|----|-----|-----|-----|----|-----|-----|-----|----|-----|-----|-----|----|-----|-----|-----|----|-----|-----|-----|----|-----|-----|-----|----|-----|-----|-----|----|-----|-----|-----|----|-----|-----|-----|----|-----|-----|-----|----|-----|-----|-----|----|-----|-----|-----|----|-----|-----|-----|----|-----|-----|-----|----|-----|-----|-----|----|-----|-----|-----|----|-----|-----|-----|----|-----|-----|-----|----|-----|-----|-----|----|-----|-----|-----|----|-----|-----|-----|----|-----|-----|-----|----|-----|-----|-----|----|-----|-----|-----|----|-----|-----|-----|----|-----|-----|-----|----|-----|-----|-----|----|-----|-----|-----|-----|------|------|------|-----|------|------|------|-----|------|------|------|-----|------|------|------|-----|------|------|------|-----|------|------|------|-----|------|------|------|-----|------|------|------|-----|------|------|------|-----|------|------|------|-----|------|------|------|-----|------|------|------|-----|------|------|------|-----|------|------|------|-----|------|------|------|-----|------|------|------|-----|------|------|------|-----|------|------|------|-----|------|------|------|-----|------|------|------|-----|------|------|------|-----|------|------|------|-----|------|------|------|-----|------|------|------|-----|------|------|------|-----|------|------|------|-----|------|------|------|-----|------|------|------|-----|------|------|------|-----|------|------|------|-----|------|------|------|-----|------|------|------|-----|------|------|------|-----|------|------|------|-----|------|------|------|-----|------|------|------|-----|------|------|------|-----|------|------|------|-----|------|------|------|-----|------|------|------|-----|------|------|------|-----|------|------|------|-----|------|------|------|-----|------|------|------|-----|------|------|------|-----|------|------|------|-----|------|------|------|-----|------|------|------|-----|------|------|------|-----|------|------|------|-----|------|------|------|-----|------|------|------|-----|------|------|------|-----|------|------|------|-----|------|------|------|-----|------|------|------|-----|------|------|------|-----|------|------|------|-----|------|------|------|-----|------|------|------|-----|------|------|------|-----|------|------|------|-----|------|------|------|-----|------|------|------|-----|------|------|------|-----|------|------|------|-----|------|------|------|-----|------|------|------|-----|------|------|------|-----|------|------|------|-----|------|------|------|-----|------|------|------|-----|------|------|------|-----|------|------|------|-----|------|------|------|-----|------|------|------|-----|------|------|------|-----|------|------|------|-----|------|------|------|-----|------|------|------|-----|------|------|------|-----|------|------|------|-----|------|------|------|-----|------|------|------|-----|------|------|------|-----|------|------|------|-----|------|------|------|-----|------|------|------|-----|------|------|------|-----|------|------|------|-----|------|------|------|-----|------|------|------|-----|------|------|------|-----|------|------|------|-----|------|------|------|-----|------|------|------|-----|------|------|------|-----|------|------|------|-----|------|------|------|-----|------|------|------|-----|------|------|------|-----|------|------|------|-----|------|------|------|-----|------|------|------|-----|------|------|------|-----|------|------|------|-----|------|------|------|-----|------|------|------|-----|------|------|------|-----|------|------|------|-----|------|------|------|-----|------|------|------|-----|------|------|------|-----|------|------|------|-----|------|------|------|-----|------|------|------|-----|------|------|------|-----|------|------|------|-----|------|------|------|-----|------|------|------|-----|------|------|------|-----|------|------|------|-----|------|------|------|-----|------|------|------|-----|------|------|------|-----|------|------|------|-----|------|------|------|-----|------|------|------|-----|------|------|------|-----|------|------|------|-----|------|------|------|-----|------|------|------|-----|------|------|------|-----|------|------|------|-----|------|------|------|-----|------|------|------|-----|------|------|------|-----|------|------|------|-----|------|------|------|-----|------|------|------|-----|------|------|------|-----|------|------|------|-----|------|------|------|-----|------|------|------|-----|------|------|------|-----|------|------|------|-----|------|------|------|-----|------|------|------|-----|------|------|------|-----|------|------|------|-----|------|------|------|-----|------|------|------|-----|------|------|------|-----|------|------|------|-----|------|------|------|-----|------|------|------|-----|------|------|------|-----|------|------|------|-----|------|------|------|-----|------|------|------|-----|------|------|------|-----|------|------|------|-----|------|------|------|-----|------|------|------|-----|------|------|------|-----|------|------|------|-----|------|------|------|-----|------|------|------|-----|------|------|------|-----|------|------|------|-----|------|------|------|-----|------|------|------|-----|------|------|------|-----|------|------|------|-----|------|------|------|-----|------|------|------|-----|------|------|------|-----|------|------|------|-----|------|------|------|-----|------|------|------|-----|------|------|------|-----|------|------|------|-----|------|------|------|-----|------|------|------|-----|------|------|------|-----|------|------|------|-----|------|------|------|-----|------|------|------|-----|------|------|------|-----|------|------|------|-----|------|------|------|----|

# Simplicity

Thank you for purchasing this Simplicity pattern. We made every effort to provide you with a high quality product.

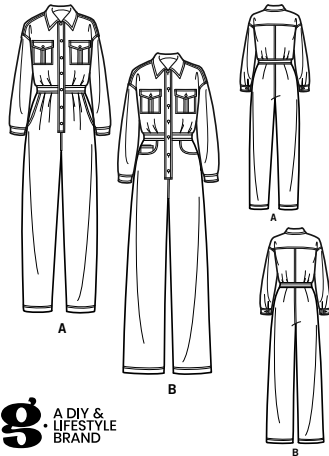

**miG** A DIY & LIFESTYLE BRAND

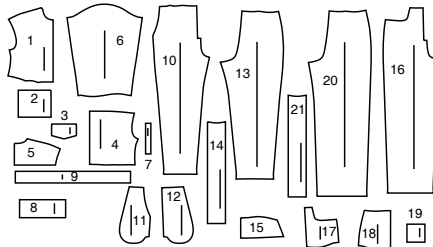

- 1 Bodice Front-A,B
- 2 Upper Pocket-A,B
- 3 Flap-A,B
- 4 Back-A,B
- 5 Yoke Back-A,B
- 6 Sleeve-A,B
- 7 Continuous Lap-A,B
- 8 Cuff-A,B
- 9 Midriff-A,B
- 10 Pants Front-A
- 11 Pocket Facing-A
- 12 Side Front and Pocket-A
- 13 Pants Back-A
- 14 Placket-A
- 15 Collar-A,B
- 16 Pants Front-B
- 17 Pocket Facing-B
- 18 Side Front and Pocket-B
- 19 Inside Pocket-B
- 20 Pants Back-B
- 21 Placket-B

## General Directions

### The Pattern

- GRAIN LINE** Place on straight grain of fabric parallel to selvage
- PLACE SOLID LINE** on fold of fabric.
- CENTER FRONT OR BACK** of garment.
- NOTCHES**
- DOTS**
- CUTTING LINE**
- LENGTHEN OR SHORTEN LINES**

**SEAM ALLOWANCE:** 5/8" (1.5cm) unless otherwise stated is included but not printed on MULTI-SIZE PATTERNS. Mark your size with colored felt tip pen. See chart on tissue for how to use MULTI-SIZE PATTERNS.

### ADJUST IF NEEDED

- MAKE ADJUSTMENTS** before placing pattern on fabric.
- TO LENGTHEN:** Cut pattern between lengthen or shorten lines. Spread pattern evenly, the amount needed and tape to paper.
- TO SHORTEN:** At lengthen or shorten lines, make an even pleat taking up amount needed. Tape in place.

When lengthen or shorten lines are not given, make adjustments at lower edge of pattern.

### Cutting/Marking

- BEFORE CUTTING:** PRESS pattern pieces with a warm dry iron. PRE-SHRINK fabric by pre-washing washables or steam-pressing non-washables.
- CIRCLE your cutting layout.
- PIN pattern to fabric as shown in Cutting Layouts.
- FOR DOUBLE THICKNESS: Fold fabric with RIGHT sides together.
  - FOR SINGLE THICKNESS: Place fabric RIGHT side up.
  - FOR PILE, SHADED OR ONE WAY DESIGN FABRICS: Use "with nap" layouts

**AFTER CUTTING:** Transfer markings to WRONG side of fabric before removing pattern. Use pin and chalk method or dressmaker's tracing paper and wheel.

- To Quick Mark:**
- Snip edge of fabric to mark notches, ends of fold lines and center lines.
  - Pin mark dots.



### Sewing

- SEW garment following **Sewing Directions**.
- PIN or machine-baste seams matching notches.
- STITCH 5/8" (1.5 cm) seams unless otherwise stated.
- PRESS seams open unless otherwise indicated clipping when necessary so seams will lie flat.
- TRIM seams to reduce bulk, as shown below.

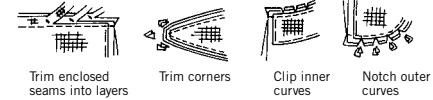

### SPECIAL CUTTING NOTES

- ★ If layout shows a piece extending past fold, cut out all pieces except piece that extends.
  - ✱ Mark small arrows along both selvages indicating direction of nap or design. Fold fabric crosswise with RIGHT sides together, and cut along fold (a).
- Open out fabric to single thickness. Cut extending piece on RIGHT side of fabric in position shown.
- Turn one fabric layer around so arrows on both layers go in the same direction. Place RIGHT sides together (b).

## Cutting Layouts

- WRONG SIDE OF FABRIC
- RIGHT SIDE OF FABRIC
- PATTERN PIECE WITH PRINTED SIDE UP
- PATTERN PIECE WITH PRINTED SIDE DOWN
- ★ SEE SPECIAL CUTTING NOTES

POSITION OF PATTERN PIECES MAY VARY SLIGHTLY ACCORDING TO YOUR PATTERN SIZE

### JUMPSUIT A

USE PIECES 1 2 3 4 5 6 7 8 9 10 11 12 13 14 15

45" (115CM) WITH NAP  
SIZES 8 10 12 14 16

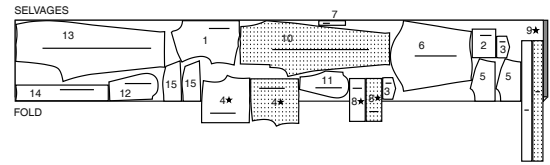

45" (115CM) WITH NAP  
SIZES 18 20 22 24 26

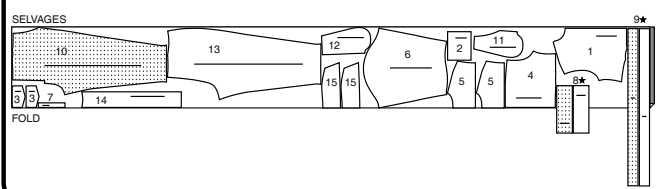

60" (150CM) WITH NAP  
SIZES 8 10 12 14 16

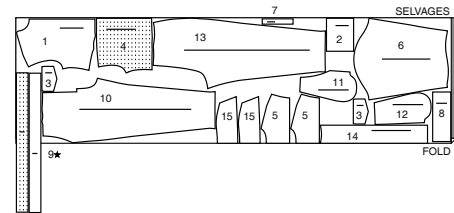

60" (150CM) WITH NAP  
SIZES 18 20 22 24 26

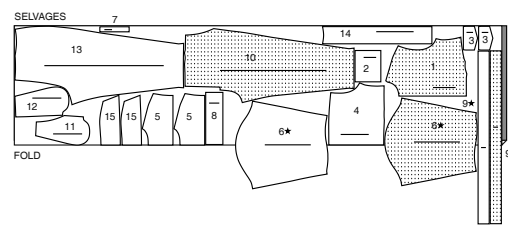

### INTERFACING A

USE PIECES 3 8 9 14 15

20" (51CM) ALL SIZES

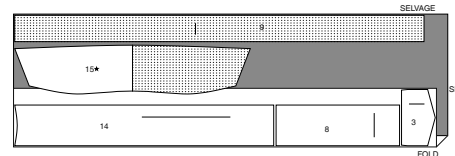

### JUMPSUIT B

USE PIECES 1 2 3 4 5 6 7 8 9 15 16 17 18 19 20 21

45" (115CM) WITH NAP  
SIZES 8 10 12 14 16

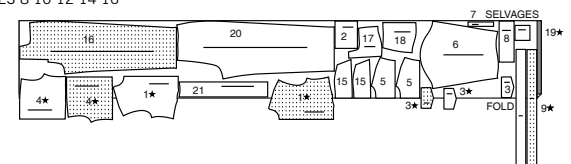

45" (115CM) WITH NAP  
SIZES 18 20 22 24 26

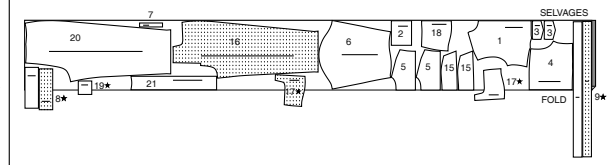

60" (150CM) WITH NAP  
SIZES 8 10 12 14 16

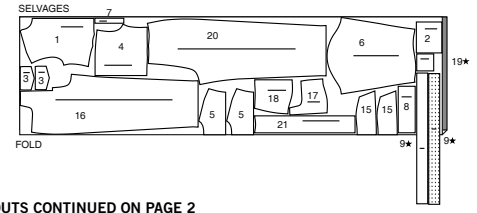

CUTTING LAYOUTS CONTINUED ON PAGE 2

60" (150CM)  
WITH NAP  
SIZES 18 20 22 24 26

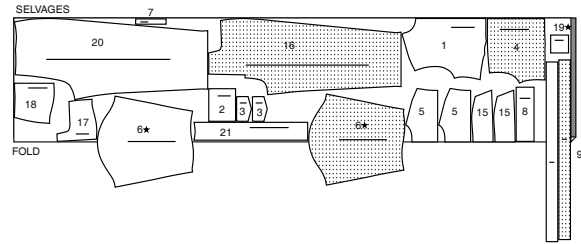

## INTERFACING B

USE PIECES 3 8 9 15 21

20" (51CM)  
ALL SIZES

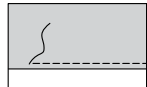
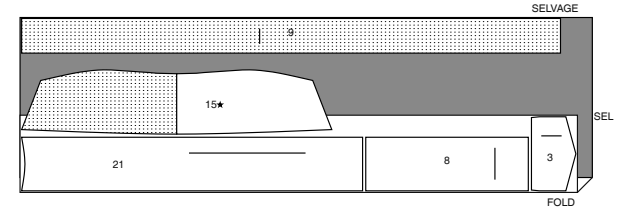

EDGESTITCH

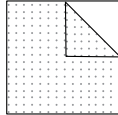

INTERFACING



STAYSTITCH

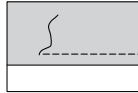

TOPSTITCH

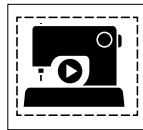

SCAN QR CODE  
FOR A  
STEP-BY-STEP  
VIDEO TUTORIAL



## Sewing Directions

**FABRIC KEY** **RIGHT SIDE** **WRONG SIDE** **INTERFACING** **LINING** **LINING**

Read **General Directions** on page 1 before you begin.

Sewing terms appearing in **BOLD TYPE** in Sewing Instructions are explained below.

**EDGESTITCH** – Stitch close to finished edge or seam.

**INTERFACING** – Pin fusible interfacing to wrong side of fabric. Fuse in place following manufacturer's directions.

**STAYSTITCH** – Stitch 1/8" (3mm) from seamline in seam allowance (usually 1/2" (13mm) from raw edge) in the direction of the arrows.

**TOPSTITCH** – On outside, stitch 1/4" (6mm) from edge, seam or previous stitching, using presser foot as guide, or stitch where indicated in instructions.

**PATTERN PIECES WILL BE IDENTIFIED BY NUMBERS THE FIRST TIME THEY ARE USED.**

**STITCH 5/8" (1.5CM) SEAMS WITH RIGHT SIDES TOGETHER UNLESS OTHERWISE STATED.**

## JUMPSUIT A, B

- To make pleat on upper pocket (2), on OUTSIDE, bring broken lines together. Stitch along broken lines. Press pleat flat, bringing stitching to center.
- On OUTSIDE, **EDGESTITCH** and **TOPSTITCH** pressed edges of pocket, keeping edges free. Baste across raw edge.
- Press under 1/4" (6mm) on upper edge of pocket. Turn upper edge to OUTSIDE along fold line, forming facing. Stitch along seam line on raw edges. Trim seam allowance in the facing area to 1/4" (6mm).
- Turn corners RIGHT side out, turning facing to the WRONG side; press, pressing under raw edges along stitching. Stitch facing close to inner edge.
- FOR VIEW A** – Apply knob section of snap fastener to pocket at small dot through all thicknesses, following manufacturer's directions.

**CONTINUE AS FOLLOWS FOR BOTH VIEWS**

- STAYSTITCH** neck edge of bodice front (1). On OUTSIDE, pin pocket to front, matching large dots. **EDGESTITCH** and **TOPSTITCH** close to side and lower edges.
- Apply **INTERFACING** to flap (3). With RIGHT sides together, stitch facing to flap, leaving edge with small dots open. Trim seam and corners.
- Turn flap; press. Machine-baste 5/8" (1.5cm) from raw edge. **EDGESTITCH** and **TOPSTITCH** close to side and lower edges. **FOR VIEW A** – Apply socket section of snap fastener to flap at buttonhole marking through all thicknesses, following manufacturer's directions. **FOR VIEW B** – Make buttonhole at marking.

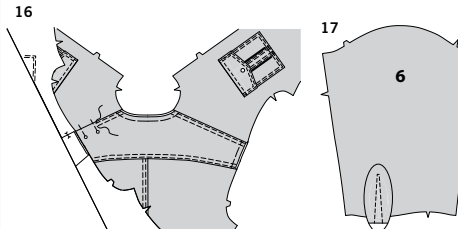
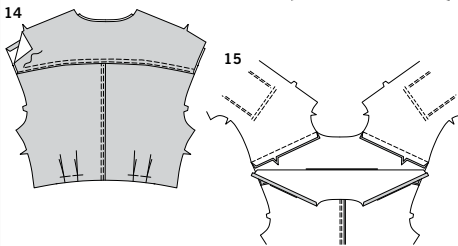
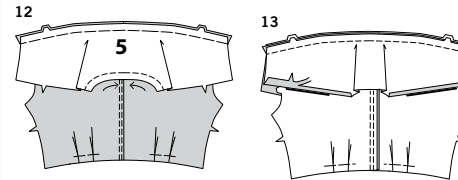
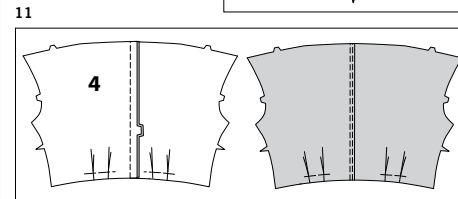
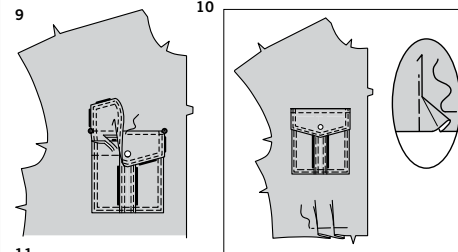

9

10

11

12

13

14

15

16

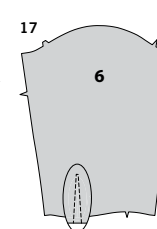
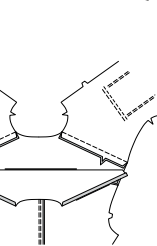
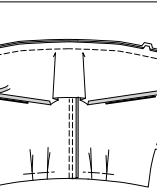
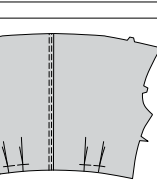
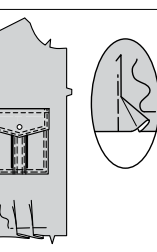

- On OUTSIDE, pin flap to bodice front, placing basting along flap line, matching small dots, as shown. Stitch along basting. Trim close to stitching. Turn flap down; press. **TOPSTITCH** close to upper edge.

- To make pleats on bodice front sections, on OUTSIDE, fold along solid lines. Bring folds to broken lines; pin. Baste across raw edge.

- Make pleats on back (4) sections in the same manner as bodice front. Stitch center back edges together. Press seam toward LEFT back. On OUTSIDE, **EDGESTITCH** and **TOPSTITCH** LEFT back along seamline.

- STAYSTITCH** neck edge of yoke back (5) and yoke back facing. With RIGHT sides together, pin back to yoke back, matching centers. Baste.

- Press under 5/8" (1.5cm) on shoulder edges of yoke facing; trim to 1/4" (6mm). Pin RIGHT side of yoke facing to WRONG side of back, matching centers. Baste. Stitch seam through all thicknesses.

- Press yoke and facing out. On OUTSIDE, **EDGESTITCH** and **TOPSTITCH** yoke along seamline.

- With RIGHT sides together, pin front sections to yoke back at forward shoulder seams. Baste. Stitch. Press seam toward yoke.

- Pin pressed edges of yoke facing over forward shoulder seams, placing pins on OUTSIDE. On OUTSIDE, **EDGESTITCH** and **TOPSTITCH** yoke along seamline, catching in pressed edge of yoke facing on the INSIDE. Baste neck, and armhole edges together.

- To make slash opening at lower edge of sleeve (6), stitch along stitching lines. Pivot and take one small stitch across the point.

S9822

3 of 4

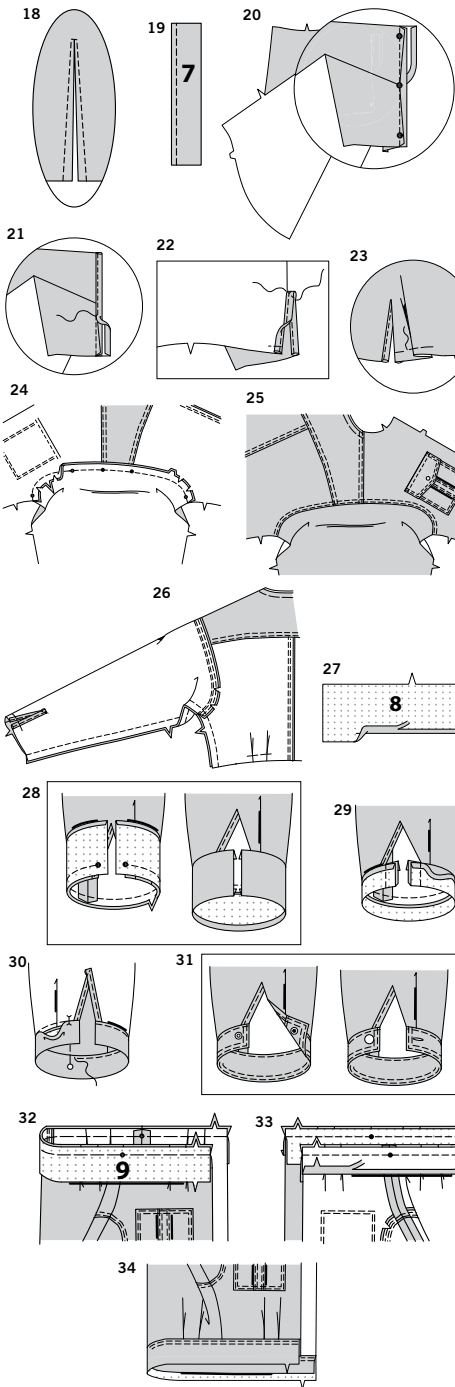

18. Slash between stitching, being careful not to slash through the point.

19. Stitch along stitching line on continuous lap (7).

20. Spread slashed edges of sleeve apart so that they form a straight line. Baste RIGHT side of lap to WRONG side of slashed edges, matching stitching lines and small dots. Stitch along stitching line. Press lap out, pressing seam toward lap. Press under 1/4" (6mm) on remaining long edge of lap.

21. Stitch pressed edge over seam.

22. Press front portion of lap to INSIDE; baste in place across lower edge. Stitch across upper edge of fold diagonally, as shown.

23. To make pleat, on OUTSIDE, fold along solid line. Bring fold to broken line; pin. Baste across lower edge.

24. With RIGHT sides together, pin sleeve to armhole edge with center small dot at shoulder seam, matching notches and remaining small dots. Stitch. Clip curves. Press seam toward garment.

25. On OUTSIDE, **EDGESTITCH** and **TOPSTITCH** bodice front and back close to armhole seam.

26. Stitch bodice front to back at entire underarm seam, matching armhole seams.

27. Apply **INTERFACING** to cuff (8). Press under 5/8" (1.5cm) on unnotched edge of cuff. Trim to 1/4" (6mm).

28. With RIGHT sides together, pin sleeve to cuff, placing opening edges at small dots. Baste. Stitch. Trim seam. Press seam toward cuff, pressing cuff out.

29. Fold cuff along fold line, with RIGHT sides together. Stitch ends. Trim seams.

30. Turn cuff; press. On INSIDE, pin pressed edge of cuff over seam, placing pins on OUTSIDE. On OUTSIDE, **EDGESTITCH** cuff close to seam, catching in pressed edge of cuff on INSIDE. If you prefer, **TOPSTITCH** cuff along edgestitch.

31. **EDGESTITCH** and **TOPSTITCH** remaining outer edges of cuff. **FOR VIEW A** – Apply socket section of snap fasteners at buttonhole marking, and knob section of snap at small dot, following manufacturer's directions. **FOR VIEW B** – Make buttonhole at marking. Sew button to cuff at small dot.

32. Apply **INTERFACING** to midriff (9). With RIGHT sides together, pin midriff to lower edge of bodice front and back, matching notches, placing small dots at side seams. Baste.

33. Press under 5/8" (1.5cm) on lower edge of midriff facing; trim to 1/4" (6mm). Pin RIGHT side of midriff facing to WRONG side of bodice front and back, matching notches, placing small dots at side seams. Baste. Stitch seam through all thicknesses.

34. Press midriff and midriff facing out. On OUTSIDE, **EDGESTITCH** and **TOPSTITCH** midriff along seamline.

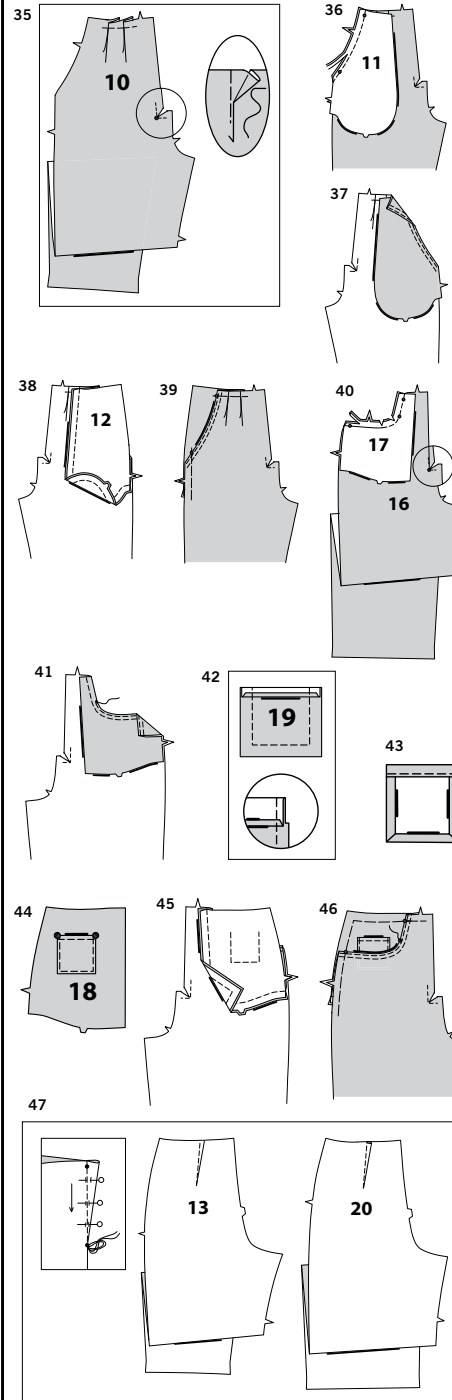

### PANTS FRONT A

35. Stitch along stitching lines at small dot at inner corner on pants front (10). Clip to stitching at the small dot. To make pleats on pants front, on OUTSIDE, fold along solid lines. Bring folds to broken lines; pin. Baste across raw edge.

36. With RIGHT sides together and raw edges even, pin pocket facing (11) to pants front, matching small dots. Stitch single notched, curved edge. Trim seam.

37. Turn facing to INSIDE; press. On OUTSIDE, **EDGESTITCH** and **TOPSTITCH** finished edge.

38. On INSIDE, with RIGHT sides together, pin side front and pocket (12) to pocket facing, having raw edges even. Stitch double notched edge, as shown.

39. On OUTSIDE, lap pants front over front and pocket section, matching small dots, having raw edges even; pin. Baste side and upper edges together.

### PANTS FRONT B

40. Stitch along stitching lines at small dot at inner corner on pants front (16). Clip to stitching at the small dot. With RIGHT sides together and raw edges even, pin pocket facing (17) to pants front, matching small dots. Stitch single notched, upper edge. Trim seam.

41. Turn facing to INSIDE; press. On OUTSIDE, **EDGESTITCH** to inner small dot and **TOPSTITCH** entire finished edge.

42. Press under a scant 1/4" (6mm) on upper edge of inside pocket (19). Turn upper edge to OUTSIDE along 5/8" (1.5cm) seam line, forming facing. Stitch along seam line on raw edges. Trim seam allowance in the facing area to 1/4" (6mm).

43. Turn corners RIGHT side out, turning facing to the WRONG side; press, pressing under raw edges along stitching. Stitch facing close to inner edge.

44. On OUTSIDE, pin inner pocket to RIGHT side front and pocket (18), matching large dots. **EDGESTITCH** close to side and lower edges.

45. On INSIDE, with RIGHT sides together, pin side front and pocket to pocket facing, having raw edges even. Stitch front and double notched edge, as shown.

46. On OUTSIDE, lap pants front over side front and pocket section, matching small dots, having raw edges even; pin. Baste side and upper edges together. **EDGESTITCH** pocket facing from inner small dot to upper edge, connecting to previous stitching.

### CONTINUE AS FOLLOWS FOR BOTH VIEWS

47. To make darts in pants back (13 OR 20), with RIGHT sides together, bring broken lines together, matching small dots. Stitch along broken line from wide end to point. Press dart toward center.

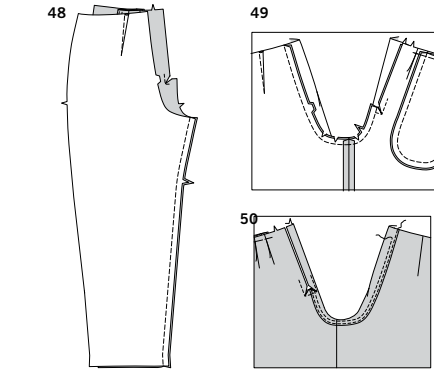

**48.** Pin pants front to pants back at inner leg edges, matching notches. Stitch.

**49.** With RIGHT sides together, pin center seam, matching inner leg seams and notches. Stitch notched edges. To reinforce seam, stitch again over first stitching. Clip seam along curve. Press seam toward LEFT side.

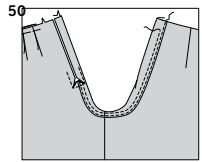

**50.** On OUTSIDE, **EDGE**STITCH and **TOP**STITCH LEFT side of center seam, as shown.

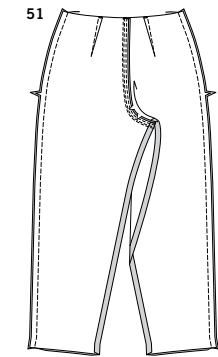

**51.** Stitch pants front to pants back at side edges.

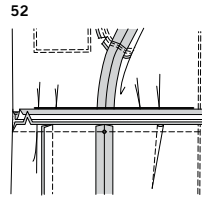

**52.** Move midriff facing away from seam allowance. With RIGHT sides together and raw edges even, pin upper edge of pants to lower edge of midriff, matching notches, placing small dots at side seams. Stitch. Press seam toward midriff.

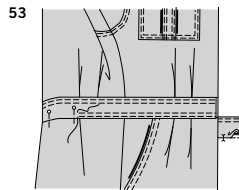

**53.** Pin pressed edge of midriff facing over seam, placing pins on OUTSIDE. On OUTSIDE, **EDGE**STITCH and **TOP**STITCH close to seam, catching in pressed edge of facing on the INSIDE.

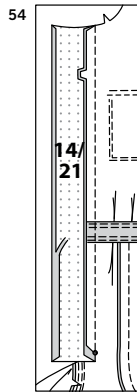

**54.** Apply **INTERFACING** to placket (14 OR 21) sections. Press under a scant 5/8" (1.5cm) on unnotched edge. Trim to 1/4" (6mm). With RIGHT sides together and raw edges even, pin placket to front edges, matching small dots and notches. Stitch from upper edge to small dot, back-stitching at dot to reinforce the seam. Press seam toward placket, pressing placket out.

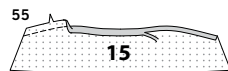

**55.** Apply **INTERFACING** to one collar (15) section. Machine-stitch 5/8" (1.5cm) from notched edge of collar. Press under raw edge along stitching. Trim to 3/8" (1cm).

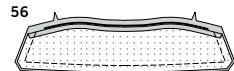

**56.** With RIGHT sides together, stitch facing to collar, leaving notched edge open. Trim seam and corners.

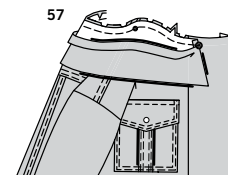

**57.** Turn collar, press. Clip neck edge of jumpsuit to stay-stitching. On OUTSIDE, pin collar facing to neck edge, matching centers and large dots, placing small dot at shoulder seam, keeping pressed edge of collar away from seam allowance. Stitch.

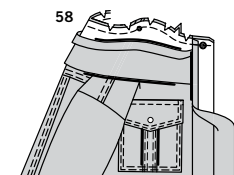

**58.** Turn front edge of placket to OUTSIDE along fold line, forming facing; stitch to neck edge, being careful not to catch in free edge of collar. Trim seam; clip curves.

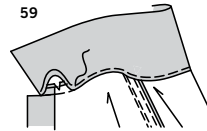

**59.** Turn placket facing to INSIDE along foldline, turning back neck seam toward collar; press. On INSIDE, stitch pressed edge of collar over neck seam.

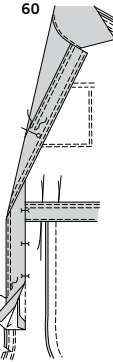

**60.** On INSIDE, pin pressed edge of placket over seam, placing pins on OUTSIDE. On OUTSIDE, **EDGE**STITCH and **TOP**STITCH placket close to seam line and front edge.

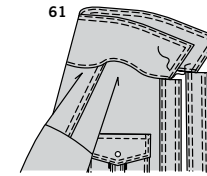

**61.** **EDGE**STITCH and **TOP**STITCH finished edges of collar.

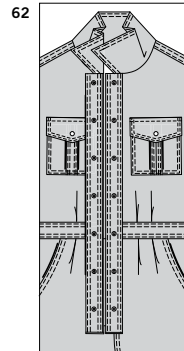

**62.** FOR VIEW A – Apply socket sections of snap fasteners to RIGHT placket at small dots, and knob sections to LEFT placket at small dots, following manufacturer's directions.

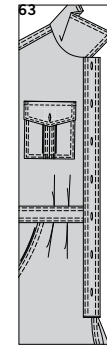

**63.** FOR VIEW B – Make buttonholes on RIGHT placket at markings.

#### CONTINUE AS FOLLOWS FOR BOTH VIEWS

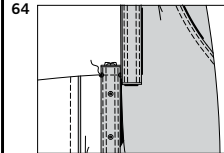

**64.** Fold RIGHT side of jumpsuit down with RIGHT sides together along stitching line at inner corner of pants front. Baste end of placket over upper edge of center seam, matching small dots, keeping LEFT placket free.

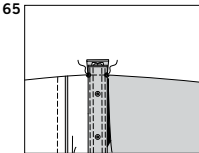

**65.** Fold LEFT side of jumpsuit down with WRONG sides together along stitching line at inner corner of pants front. Bring lower seam allowances of plackets together, lapping RIGHT placket over LEFT, matching centers, sandwiching center front seam allowance. Stitch between the small dots. Trim seam close to stitching.

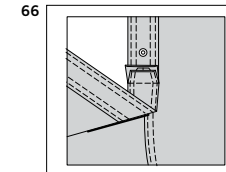

**66.** Press up plackets over seam allowance, matching centers. On OUTSIDE, **EDGE**STITCH and **TOP**STITCH placket close to seam.

#### FINISHING

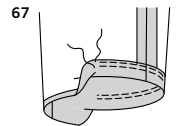

**67.** Press up hem allowance on lower edge of pant legs. Turn under raw edge 1/4" (6mm). **EDGE**STITCH and **TOP**STITCH hem in place.

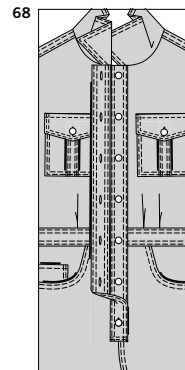

**68.** FOR VIEW B – Sew buttons to upper pocket at small dot, and LEFT placket under buttoholes.



# Congrats!

You've completed your sewing adventure

---

**SHARE  
YOUR** LOOK



Post your pattern and tag us  
**@simplicity\_creative\_group** and **#simplicitypatterns**  
for a chance to be featured on our social media.

Look for more PDF patterns at **simplicity.com**

Have a question or need help with your sewing project call us at  
1-888-588-2700



Simplicity ©2023 a division of IG Design Group Americas Inc. • Atlanta, GA 30342 USA [www.thedesigngroup.com](http://www.thedesigngroup.com) • All Rights Reserved. [www.simplicity.com](http://www.simplicity.com) • Made in the U.S.A. Fabriqué aux États-Unis.

To be used for individual private home use only and not for commercial or manufacturing purposes. • A usage privé seulement et non à des fins commerciales ou de production en série. • Para uso privado solamente, no se puede utilizar con propósitos de comercialización o de producción en serie.