

S9809

Simplicity



Shop all the pattern brands you love @

Simplicity.com

Average

PINCUSHION DOLLS, PROJECT ORGANIZER AND ETUI

Suggested Fabrics: Chambray, Chintz, Cotton Types, Linen Types. **A, B** also in Dupioni, Lightweight Velvet, Satin. **Pincushion D** in Felt. **Padding C, D:** Fusible Fleece. **Interfacing A, B, C, D:** Lightweight Fusible.

Notions: A, B: Fabric glue, 5" x 5" (13cm x 13cm) of foam core board, paper towel tube, tape, poly pellets, poly fiberfill, ½ yd. (0.5m) of large rick rack.

Also for A: 6" (15cm) doll, ¾ yd. (0.6m) of ¼" (6mm) cord, 1 yd. (1.0m) of ¼" (2.2cm) ribbon, ¾ yd. (0.7m) of ¾" - ½" (1cm - 1.3cm) lace edging, ¾ yd. (0.5m) of ¾" (1cm) ribbon (for hair), 4" (10cm) length of ¼" (3mm) cord (for crown).

Also for B: 3½" (9cm) doll, ¾ yd. (0.4m) of ¼" - ⅛" (3mm - 6mm) cord, ¼ yd. (0.3m) of ½" (1.3cm) ribbon, ¼ yd. (0.2m) of ¾" (1cm) ribbon (for bow), ¾ yd. (0.3m) of baby rick rack, ¾ yd. (0.3m) of ¾" - 1" (2cm - 2.5cm) flat lace or eyelet trim.

C: 1½ yds. (1.3m) of ½" (1.3cm) cord with lip, 1½ yds. (1.3m) of 1" (2.5cm) ribbon, ¼ yd. (0.3m) of ½" (1.3cm) ribbon, ¾ yd. (0.7m) of large rick rack, two 1" (2.5cm) plastic rings.

D: 1½ yds. (1.1m) of ½" (1.3cm) cord with lip, ¾ yd. (0.7m) of large rick rack, 1 yd. (1.0m) of ¾" (1.5cm) ribbon, ½ yd. (0.4m) of ¾" (1cm) elastic, one ¾" (1.5cm) plastic ring, ½" (1.3cm) length of ½" (1.3cm) hook and loop tape.

Pincushion Doll A

45** - ¼ yd. (115cm* - 0.2m)

Interfacing: 20" - ¼ yd. (51cm* - 0.2m)

Pincushion Doll B

45** - ¼ yd. (115cm* - 0.2m)

Interfacing: 20" - ¼ yd. (51cm* - 0.2m)

Organizer C

45** - ¾ yd. (115cm* - 0.7m)

Contrast 1 (Upper Pocket): 45** - ½ yd. (115cm* - 0.5m)

Contrast 2 (Lower Pocket): 45** - ¾ yd. (115cm* - 0.3m)

Contrast 3 (Binding): 21" x 21" (53cm x 53cm) fabric remnant

Contrast 4 (Middle Pocket): 11" x 11" (28cm x 28cm) fabric remnant

Padding: 45" - ½ yd. (115cm* - 0.5m)

Interfacing: 20" - 1½ yds. (51cm* - 1.3m)

Etui D

45** - ¾ yd. (115cm* - 0.3m)

Contrast 1 (Upper Front, Upper Front Pencil Pocket): 45** - ¾ yd. (115cm* - 0.3m)

Contrast 2 (Upper Front Pocket, Middle Upper Back): 45** - ¼ yd. (115cm* - 0.2m)

Contrast 3 (Lower Front Pocket, Upper Back Pocket): 9" x 11" (23cm x 28cm) fabric remnant

Contrast 4 (Binding): 13" x 13" (33cm x 33cm) fabric remnant

Contrast 5 (Pincushion): 4" x 5" (10cm x 13cm) felt remnant

Padding: 45" - ¾ yd. (115cm* - 0.4m)

Interfacing: 20" - ½ yd. (115cm* - 0.5m)

*with nap **without nap



A



B



B

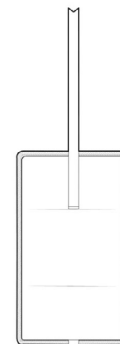

C

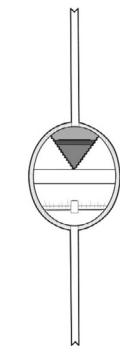

D

Simplicity® S9809

Thank you for purchasing this Simplicity pattern. We made every effort to provide you with a high quality product.

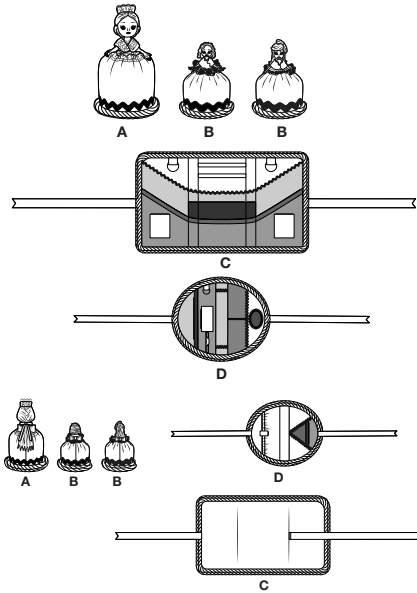

25 PIECES

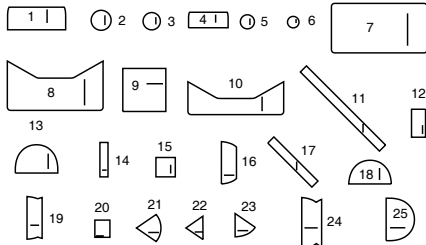

- 1 SKIRT - A
- 2 BASE - A
- 3 GUIDE - A
- 4 SKIRT - B
- 5 BASE - B
- 6 GUIDE - B
- 7 FRONT AND BACK - C
- 8 UPPER POCKET - C
- 9 MIDDLE POCKET - C
- 10 LOWER POCKET - C
- 11 BINDING - C
- 12 POCKET - C
- 13 UPPER FRONT - D
- 14 UPPER FRONT PENCIL POCKET - D
- 15 UPPER FRONT MIDDLE POCKET - D
- 16 UPPER FRONT POCKET - D
- 17 BINDING - D
- 18 LOWER FRONT - D
- 19 LOWER FRONT POCKET - D
- 20 PINCUSHION - D
- 21 MIDDLE UPPER BACK - D
- 22 UPPER BACK POCKET - D
- 23 SIDE UPPER BACK - D
- 24 LOWER BACK POCKET - D
- 25 LOWER BACK - D

Cutting Layouts

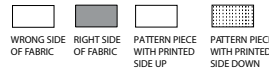

POSITION OF PATTERN PIECES MAY VARY SLIGHTLY ACCORDING TO YOUR PATTERN SIZE

General Directions For Cutting

PRE-SHRINK and iron all fabric.

FOR DOUBLE THICKNESS -Fold fabric with RIGHT sides together. Pin pattern to WRONG side of fabric.

FOR SINGLE THICKNESS -Pin pattern to RIGHT side of fabric.

★ If layout shows a piece extending past fold, cut out all pieces except piece that extends. Open out fabric to single thickness. Cut extending piece on RIGHT side of fabric in position shown.

* Mark small arrows along both selvages indicating direction of nap or design. Fold fabric crosswise with RIGHT sides together, and cut along fold. Turn one fabric layer around so arrows on both layers go in the same direction. Place RIGHT sides together.

PINCUSHION DOLL A

USE PIECE 1 2

45" (115CM) WITH NAP

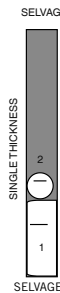

INTERFACING

USE PIECES 1 2

20" (51CM)

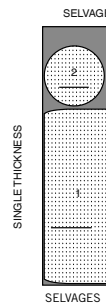

PINCUSHION DOLL B

USE PIECE 4 5

45" (115CM) WITH NAP



INTERFACING

USE PIECES 4 5

20" (51CM)

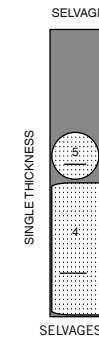

ORGANIZER C

USE PIECE 7 12

45" (115CM) WITH NAP

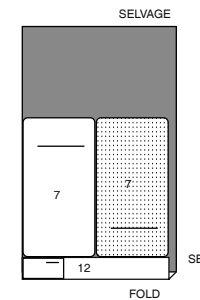

CONTRAST 1 (UPPER POCKET)

USE PIECE 8

45" (115CM) WITH NAP



CONTRAST 2 (LOWER POCKET)

USE PIECE 10

45" (115CM) WITH NAP



CONTRAST 3 (POCKET BINDING)

CUT ONE OF PIECE 11 FROM 21" X 21" (53CM X 53CM) FABRIC REMNANT

CONTRAST 4 (CENTER POCKET)

CUT ONE OF PIECE 9 FROM 11" X 11" (28CM X 28CM) FABRIC REMNANT

PADDING

USE PIECE 7

45" (115CM)

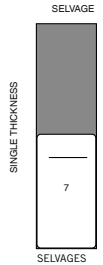

INTERFACING

USE PIECES 7 8 9 10 12

20" (51CM)

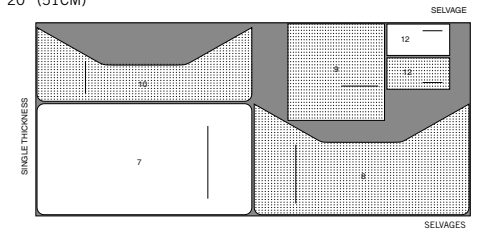

ETUI D

USE PIECES 15 18 23 24 25

45" (115CM) WITH NAP

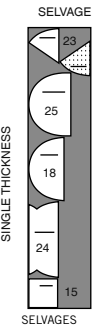

CONTRAST 1 (UPPER FRONT, UPPER FRONT PENCIL POCKET)

USE PIECES 13 14

45" (115CM) WITH NAP

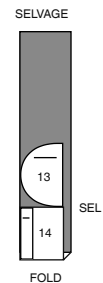

S9809

2 of 4

CONTRAST 2 (UPPER FRONT POCKET, MIDDLE UPPER BACK)

USE PIECES 16 21

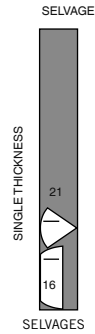
45" (115CM)
WITH NAP**CONTRAST 3 (LOWER FRONT POCKET, UPPER BACK POCKET)**

CUT ONE EACH OF PIECE 19 22 FROM FABRIC REMNANT

CONTRAST 4 (BINDING)

CUT ONE OF PIECE 17 FROM FABRIC REMNANT

CONTRAST 5 (PINCUSHION)

CUT ONE OF PIECE 20 FROM FELT REMNANT

PADDING

USE PIECE 13 18

45" (115CM)

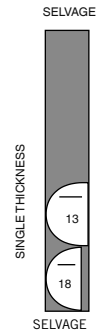
**INTERFACING**

USE PIECES 15 21 22 23 25

20" (51CM)

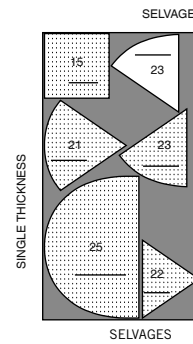
**Sewing Directions**

FABRIC KEY **RIGHT SIDE** **WRONG SIDE** **INTERFACING** **LINING** **LINING**

Read **General Directions** on page 1 before you begin.Sewing procedures **ITALICIZED** in Sewing Directions are defined below.

A- APPLY BINDING- Press under 3/8" (1cm) on one long edge of binding. With **RIGHT** sides together, pin the unpressed edge of the binding to the project, having cut edges even. Stitch in a 1/2" (1.3cm) seam.

B- Press the seam toward the binding, pressing binding out.

Fold the binding over so that it encases the cut edge and covers the stitching by at least 1/8" (3mm) on the **INSIDE**. Pin in place.

C- On **OUTSIDE**, stitch binding close to seam, catching in pressed edge on **INSIDE**.

APPLY CORD- On **OUTSIDE**, pin cord to project edges as instructed in Sewing Directions, having cord extend beyond seam line and lip edge within the seam allowance. Machine-baste as close to cord as possible without catching in the cord, using a zipper or cording foot.

When Cord Ends Meet: For a seamless effect when overlapping ends of twisted cord with lip, cut a piece of cord 3" (7.5cm) longer than the edge it is being applied to.

A - Machine-baste cord with lip in place as instructed in Sewing Directions, leaving 1-1/2" (3.8cm) un-basted at each end, where the cords will meet. At each end, separate the cords from the lip to about 1-1/2", using a seam ripper. Wrap tape around each cord separately to prevent unraveling. Lap ends of lip, tapering them slightly toward the seam allowance. Stitch in place.

B - Untwist cords on **RIGHT** side slightly and lay them over the lapped lip ends.

C - Untwist cords on **LEFT** side slightly, lay them over the **RIGHT** ones. Secure ends in place by tacking cords to lip and seam allowance, making sure the joined sections look like one continuous decorative cord along outer edge.

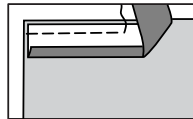
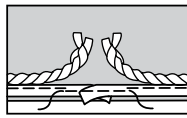
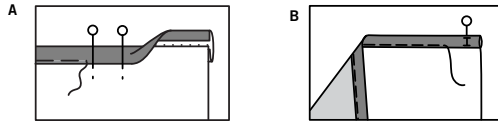
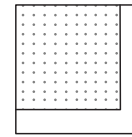
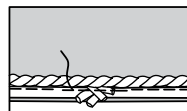
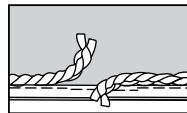
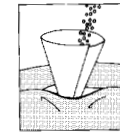
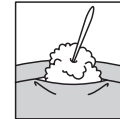
**APPLY BINDING****APPLY CORD****INTERFACING/
PADDING****PLASTIC PELLETS****STUFF**

INTERFACING/PADDING - Pin interfacing/fleece to **WRONG** side of fabric. Fuse interfacing/fleece in place following manufacturer's directions.

PLASTIC PELLETS- To make it easier to fill your project with plastic pellets, make a paper funnel by rolling up a rectangle of paper. Have a wider opening at the top and about a 1/2" (1.3cm) opening at the bottom. Place the small end in the opening. Use a small measuring cup to pour the plastic pellets into the top of the funnel.

STUFF - Pull fiberfill apart and fluff it before you use it. Break apart the lumps and thick spots. This will help to create a smoother looking project.

Use pieces about the size of a tennis ball. Pack into place using the end of a long handled wooden spoon or chop-stick.

Use small pieces and pack into place using the end of a crochet hook or chop-stick.

Pack firmly in place each time stuffing is added. Use both hands to mold and shape, being careful not to over stuff or make lopsided.

PATTERN PIECES WILL BE IDENTIFIED BY NUMBERS THE FIRST TIME THEY ARE USED.

STITCH 1/4" (6MM) SEAMS WITH RIGHT SIDES TOGETHER AND PRESS SEAMS OPEN UNLESS OTHERWISE STATED.

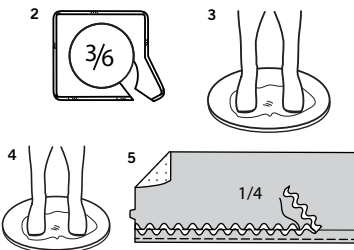
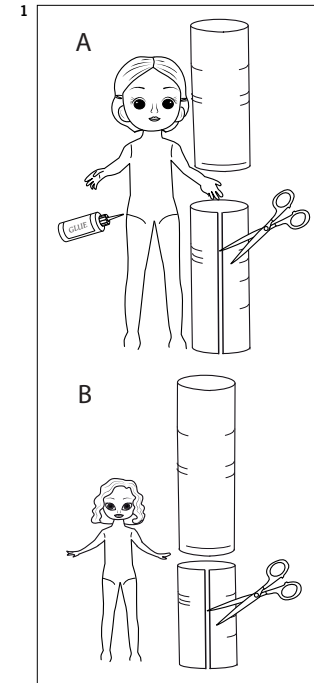
PINCUSHION DOLL A, B

1. Straighten the doll out in a standing position. Glue all the joints below the waist in a vertical position and allow to dry completely. Cut the length of paper towel tube from the waist to bottom of feet. Save the remaining tube. Cut along the length of tube.

2. Wrap the cardboard tightly around the doll at the waist area. Tape securely and repeat so you have a double layer of cardboard. Glue first layer of cardboard to the doll.

3. Trace guide (3 or 6) tissue pattern onto foam core. Cut along traced line.

4. Place cardboard tube with doll at center of foam core and trace. Remove the doll and cardboard. Place a puddle of glue **INSIDE** the circle and 1/4" (6mm) **OUTSIDE** the circle. Put the doll's feet end and cardboard into the glue and hold in place until dry. Cardboard is not shown for clarification purposes.

5. Apply **INTERFACING** to skirt (1 or 4). Machine-stitch along seam line on lower edge of skirt. On **OUTSIDE**, center rick rack along placement line for trim. Stitch along center of rick rack.

S9809

3 of 4

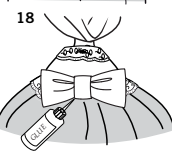
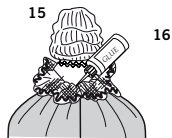
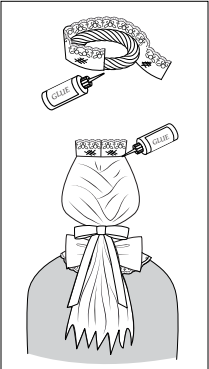
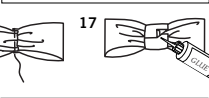
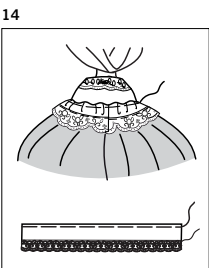
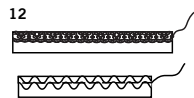
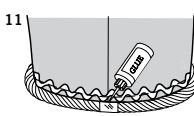
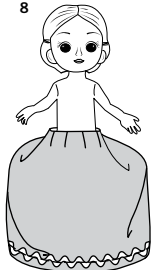
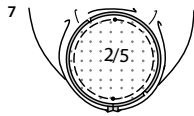
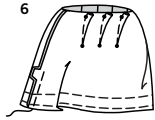

6. To make darts, with **RIGHT** sides together, bring broken lines together, matching small dots. Stitch along broken line from wide end to point. Press darts in one direction. Stitch center back seam of skirt from lower edge to notch; back-stitch at notch to reinforce seam.

7. Apply **INTERFACING** to base (2 or 5). Pin base to lower edge of skirt, matching small dots and placing remaining small dot at center back seam. Clip skirt to stitching, being careful not to clip through stitching. Stitch.

8. Turn skirt **RIGHT** side out. Insert the doll and tube into the skirt with the back of the doll at the center back seam. Pull the base snugly around the foam core with the seam allowance over the edge of the foam core. On the **INSIDE** of the skirt, glue generously around the seam allowances and foam core edges so they are held securely in place. Wait till glue fully dries.

9. Fill skirt gradually with **PLASTIC PELLETS** until it is three quarters full. Slip-stitch the center back opening edges together as you fill so you have maximum access as you work, leaving 1" (2.5cm) open at the top. **STUFF** the top one quarter of the skirt section. Push the stuffing down tightly into the pellets. Slip-stitch the remaining center back edges together. Add more stuffing through the waistline. Make the skirt full and firm, pushing stuffing in all around the darted top section with a chop-stick.

10. Hand-gather along the waist seam line and pull tightly to fit the doll's waist. Adjust dart placement evenly; fasten ends. Glue the gathered top edge of the skirt to the doll securely all around the waistline at the top of the cardboard edge.

11. Tape ends of cord to prevent raveling. Glue cord to the hem edge of the skirt over the seam, butting taped ends at center back seam.

12. FOR VIEW A- Cut a piece of ribbon 7" (18cm) long for bodice. Stitch lace edging to one edge of ribbon, as shown.
FOR VIEW B- Cut a piece of ribbon 5" (12.5cm) long for bodice. Stitch baby rick rack to one edge of ribbon, as shown.

13. FOR BOTH VIEWS- Place a drop of glue to the **UNDERSIDE** of the ribbon at the center of the ribbon. Place the ribbon with the trimmed edge at the back neck. Wrap both ends at the center front, placing **RIGHT** over **LEFT**. Adjust bodice piece so it fits over the shoulders and upper arms of the doll. Overlap and glue at the front, covering the front raw edges of skirt. Trim off excess ribbon ends diagonally after glue dries.

14. FOR VIEW A- Cut a piece of ribbon 14" (35.5cm) long for plume. Stitch lace edging to one edge of ribbon, as shown. Hand gather remaining edge of ribbon. Wrap gathered edge of ribbon around waist over raw edge of bodice front, pulling up gathering stitches to fit; fasten ends. Turn under and lap one end at center back seam. Glue gathered edge of ribbon in place all around the waist.

15. FOR VIEW B- Cut a piece of trim 8" (20cm) long for plume. Trim away jagged edge of eyelet. Hand gather straight edge of lace or eyelet trim. Wrap gathered trim around waist over raw edge of bodice front pulling up gathering stitches to fit; fasten ends. Turn under and lap one end at center back seam. Glue gathered edge of trim all around the waist.

16. For bow, cut a piece of ribbon 7" (18cm) long for **View A** or 3" (7.5cm) long for **View B**. Bring ends to **UNDERSIDE**, having ends extend 1/4+ (6mm) beyond center. Hand gather along center of bow. Pull up gathers; fasten. Glue ends in place.

17. For knot, cut a piece of ribbon 2" (5cm) long for **View A** or 1" (2.5cm) long for **View B**. Place knot around center of bow, turning under and lapping one end on **UNDERSIDE**. Glue in place.

18. Glue bow to center back of doll over bodice and skirt.

19. FOR VIEW A- Cut a piece of 1/2" (1.3cm) cord 4" (10cm) long. Butt ends and wrap with tape, forming a circle. Glue lace edging to circle to form a crown. Glue crown to doll's head. Wrap 3/8" (2cm) ribbon around hair into a bow for a pony tail.

20

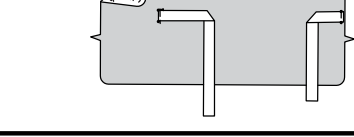
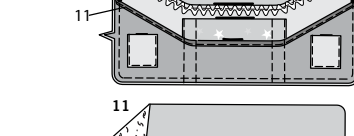
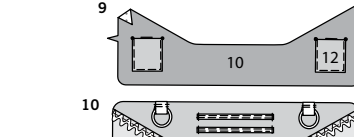
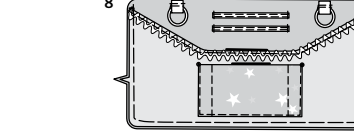
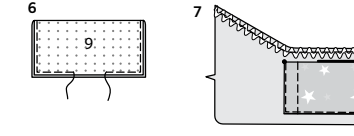
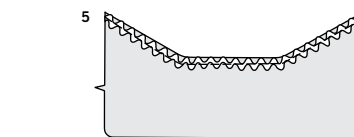
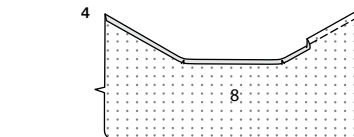
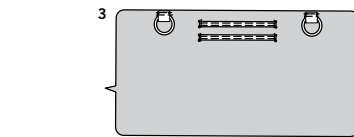
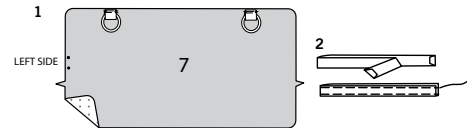

20. FOR VIEW B- Wrap baby rick rack around center of bow and glue. Glue bow to hair.
OR, glue a piece of rick rack to doll's head as shown on front of envelope.

ORGANIZER C

1. Apply **INTERFACING** to one front and back (7) section with the two small dots on the **LEFT** side edge, as shown. This is the **INSIDE** of the organizer. The remaining section is the **OUTSIDE** with the two small dots on the **RIGHT** side edge for the tie which will be applied in a later step.

Cut two pieces of ribbon each 2-1/2" (6.3cm) long. Slip ribbon through each ring, having raw ends even.
On **OUTSIDE**, pin rings to upper edge of **INSIDE** between small dots, having raw edges even. Baste. Stitch across ends of ribbon and 1/2" (1.3cm) below upper edge.

2. Cut two pieces of ribbon each 7-1/2" (19cm) long. Turn under 1/4" (6mm) on ends and fold ribbon in half, lengthwise, so it measures 1/2" (1.3cm) wide. Press. Stitch long edges together.

3. On **OUTSIDE**, pin ribbons to **INSIDE**, placing ends at small dots, as shown. Stitch close to ends of ribbon.

4. Apply **INTERFACING** to upper pocket (8). Machine-stitch along 1/2" (1.3cm) seam line on upper edge. Press under edge to **INSIDE** along stitching, clipping curves if necessary.

5. On **OUTSIDE**, stitch center of rick rack along upper edge of upper pocket, catching in raw edge on **INSIDE**.

6. Apply **INTERFACING** to middle pocket (9). Fold pocket along fold line, with **RIGHT** sides together. Stitch leaving an opening on lower edge for turning.

7. Turn pocket **RIGHT** side out; press, pressing under opening edges. On **OUTSIDE**, pin pocket to upper pocket along pocket lines, matching large dots and inner stitching lines. Stitch close to side and lower edges and along stitching lines.

8. On **OUTSIDE**, pin upper pocket to **INSIDE**, matching centers front, large dots and stitching lines, having raw edges even. Baste.

9. Apply **INTERFACING** to lower pocket (10). Make pockets (12) same as middle pocket in step 6. Turn pocket **RIGHT** side out; press, pressing under opening edges. On **OUTSIDE**, pin pockets to lower pocket along pocket lines, matching large dots. Stitch close to side and lower edges.

10. Apply **BINDING** (11) to upper edge of lower pocket. On **OUTSIDE**, pin lower pocket to upper pocket, matching stitching lines, placing upper side edges at small dots, having raw edges even. Baste. Stitch along stitching lines.

11. Apply **PADDING** to **OUTSIDE** section. Cut a piece of ribbon 16" (40.5cm) long for tie. Pin end of tie to **RIGHT** side edge between small dots, having raw edges even. Baste. Cut a piece of ribbon 24" (61cm) long for tie. Pin tie to **OUTSIDE**, placing raw end 1/4" (6mm) over solid line between small dots. Stitch 1/4" (6mm) from raw end of tie. Turn tie over raw end; press. Stitch 1/4" (6mm) from seam.

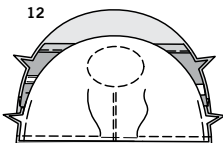
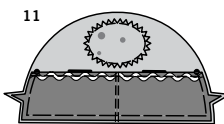
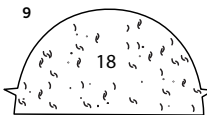
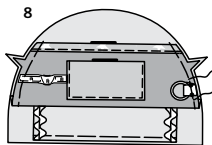
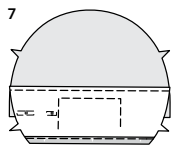
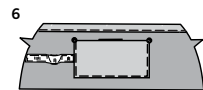
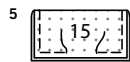
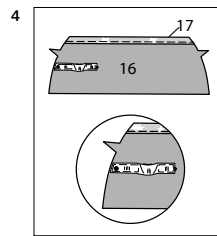
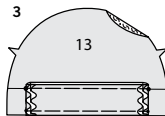
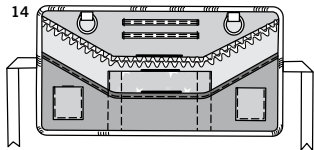
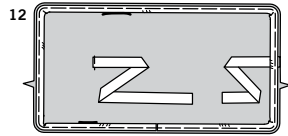

12. Apply **CORD** to outer edge of **OUTSIDE**, having ends meet on one long edge, easing in fullness along curves.

13. Pin sections together, having **RIGHT** sides together. Using a zipper or cording foot, stitch, leaving an opening large enough for turning. Be care not to catch in free ends of ties. Clip curves.

14. Turn organizer **RIGHT** side out. Slip-stitch opening edges together. Notch out ends of ties. Fold organizer and fasten ties into a bow.

ETUI D

1. Stitch upper and lower ends of upper front pencil pocket (14) sections together, matching small and large dots, leaving long edges open.

2. Turn **RIGHT** side out; press. Machine-baste raw edges together. Stitch rick rack along ends.

3. Apply **PADDING** to upper front (13). On **OUTSIDE**, pin pencil pocket to upper front, matching small and large dots, placing inner seam lines along pocket line, having raw edges even. Baste along seam lines.

4. Apply **BINDING** (17) to upper edge of upper front pocket (16). Save remaining binding for later. Cut a piece of elastic 3-1/2" (9cm) long for holder. On **OUTSIDE**, pin elastic to upper front pocket, placing inner end at small dot, and having raw edges even. Keep the elastic flat between small dots and solid lines, forming a loop between the solid lines. Stitch along long edges, squaring stitching at small dots and solid lines, keeping loop free.

5. Apply **INTERFACING** to upper front middle pocket (15). Fold pocket along fold line, with **RIGHT** sides together. Stitch leaving an opening on lower edge for turning.

6. Turn pocket **RIGHT** side out; press, pressing under opening edges. On **OUTSIDE**, pin upper front middle pocket to upper front pocket along pocket lines, matching large dots. Stitch close to side and lower edges.

7. With **RIGHT** sides together, pin upper front pocket to upper front, placing seam lines along pocket line. Stitch along seam line.

8. Turn up upper front pocket and pin to upper front, matching notches, having raw edges even. Press. Machine-baste raw edges together. Cut a piece of ribbon 2-1/2" (6.3cm) long. Slip ribbon through ring, having raw ends even. On **OUTSIDE**, pin ribbon to side edge of upper front pocket between small dots, having raw edges even. Baste.

9. Apply **PADDING** to lower front (18).

10. Stitch under 1/4" (6mm) on upper edge of lower front pocket (19) OR zig-zag over the edge OR overlock/serge over the edge. Turn upper edge to **INSIDE** long fold line forming facing. Baste.

11. On **OUTSIDE**, stitch rick rack along upper edge of lower front pocket. On **OUTSIDE**, pin lower front pocket to lower front, matching large dots and notches, having raw edges even. Machine-baste raw edges together. Stitch lower front pocket along the stitching lines. Using pinking shears, cut around pin cushion (20). On **OUTSIDE**, pin the cushion to lower front along broken line. Stitch in place.

12. With **RIGHT** sides together, pin upper front and lower front together. Stitch, leaving an opening large enough for turning later on.

13

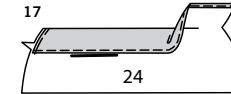
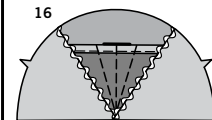
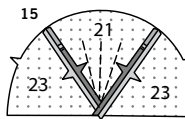
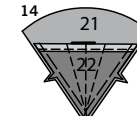
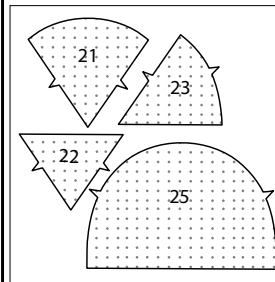

18

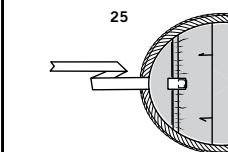
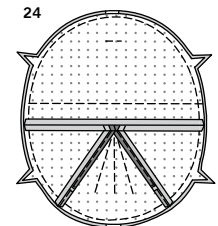
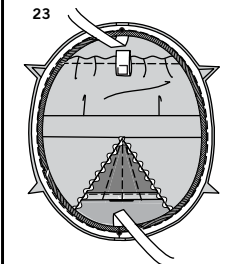
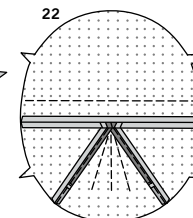
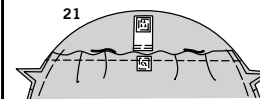
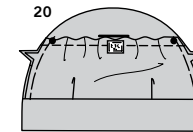
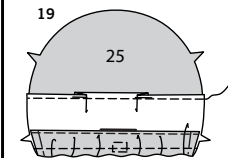
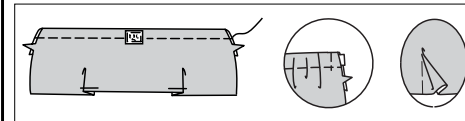

13. Apply **INTERFACING** to middle upper back (21), upper back pocket (22) side upper back (23) and lower back (25) sections.

14. Apply **BINDING** (17) to upper edge of upper back pocket. On **OUTSIDE**, pin upper back pocket to middle upper back, having side edges even. Machine-baste raw edges together. Stitch along stitching lines on upper back pocket.

15. Stitch side upper back to side edges of middle upper back.

16. On **OUTSIDE**, center rick rack over seams of upper back, folding out fullness at point. Stitch along center of rick rack.

17. Stitch under 1/4" (6mm) on upper edge of lower back pocket (24) OR zig-zag over the edge OR overlock/serge over the edge. Turn upper edge to **INSIDE** long fold line.

18. On **OUTSIDE**, stitch along stitching lines on lower back pocket, forming casing. Cut a piece of elastic 7-1/2" (19cm) long. Insert elastic through casing, having ends even. Stitch across ends of casing, catching in elastic.

To make pleats, on **OUTSIDE**, fold along solid lines. Bring folds to broken lines; pin. Baste across raw edge. Press. Separate hook and loop tape. Stitch loop half of tape to lower back pocket along solid line, keeping elastic flat while stitching. Set aside hook half of tape.

19. With **RIGHT** sides together, pin lower back pocket to lower back, placing seam lines along pocket line. Stitch along seam line.

20. Turn up lower back pocket and pin to lower back, matching large dots and notches, having raw edges even. Press. Machine-baste raw edges together.

21. Cut a piece of ribbon 3-1/2" (9cm) long. Fold ribbon in half, forming a loop. Baste raw ends together. On **OUTSIDE**, pin loop to lower back, placing raw ends 1/4" (6mm) over solid line. Stitch across end of loop along solid line and close to raw ends. Stitch hook half of tape to folded end of loop.

22. With **RIGHT** sides together, stitch upper and lower back sections.

23. Cut remaining ribbon in half for ties. On **OUTSIDE**, pin end of each tie to back at small dots, having raw edges even. Baste. Apply **CORD** to outer edge of back, easing in fullness along curves and having ends meet on middle upper back.

24. With **RIGHT** sides together, pin front to back, matching notches in upper front and upper back, making sure the upper and lower sections are coordinated. Using a zipper or cording foot, stitch, being careful not to catch in free ends of ties.

25. Turn etui **RIGHT** side out through opening in front. Slip-stitch opening edges of front together. Notch out ends of ties.



Congrats!

You've completed your sewing adventure

**SHARE
YOUR** LOOK



Post your pattern and tag us
@simplicity_creative_group and **#simplicitypatterns**
for a chance to be featured on our social media.

Look for more PDF patterns at **simplicity.com**

Have a question or need help with your sewing project call us at
1-888-588-2700



Simplicity ©2023 a division of IG Design Group Americas Inc. • Atlanta, GA 30342 USA www.thedesigngroup.com • All Rights Reserved. www.simplicity.com • Made in the U.S.A. Fabriqué aux États-Unis.

To be used for individual private home use only and not for commercial or manufacturing purposes. • A usage privé seulement et non à des fins commerciales ou de production en série. • Para uso privado solamente, no se puede utilizar con propósitos de comercialización o de producción en serie.