

S3091

Simplicity®



Designed and printed in USA.

easy-to-sew

Shop all the pattern brands you love @

**Simplicity**.com

For customers outside of the U.S. and Canada

sewdirect.com

sewdirect.com.au

Easy

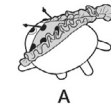

A

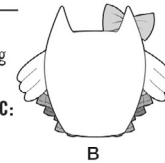

B

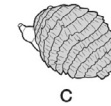

C

### PLUSH ANIMALS

**Suggested Fabrics:** Chambray, Cotton Types, Fleece, Linen Types, Seersucker. **A also in Felt.** **Lining B:** Muslin. **Appliqués A,B,C in Felt.** **Interfacing B,C:** Fusible Fleece.

**Notions: A,B,C:** Polyfiberfill. **Also for A:** Eleven ¼" (1.5cm) flat back gem stones, two 2mm flat back rhinestones, 7" (18cm) length of 3mm elastic cording, fabric glue, strong plastic adhesive glue. **Also for B:** Two ¼" (1.5cm) flat back gem stones, plastic pellets (for internal bean bag), one pkg. of medium rick rack, fabric glue, white paint. **Also for C:** Two ¼" (1cm) flat back gem stones, embroidery floss.

**Ladybug A** - 8" L x 10" W (20cm x 25cm)

36, 45, 60\*\* - ¾ yd. (91, 115, 150cm\* - 0.3m)

**Contrast (Wing, Wing Ruffle)**

45, 60\*\* - ¾ yd. (115, 150cm\* - 0.3m)

**Eye Appliqué** - 3" x 2" (8cm x 5cm) remnant each of felt and paper-backed fusible web

**Owl B** - 12" H x 10" W (30cm x 25cm)

45, 60\*\* - ½ yd. (115, 150cm\* - 0.5m)

**Contrast 1 (Ruffle 1 and 2, Bow, Knot):** 45, 60\*\* - ¾ yd. (115, 150cm\* - 0.3m)

**Contrast 2 (Ruffle 1 and 2, Ruffle 4):** 45, 60\*\* - ¼ yd. (115, 150cm\* - 0.2m)

**Contrast 3 (Ruffle 3):** 45, 60\*\* - ¼ yd. (115, 150cm\* - 0.2m)

**Eye Base Appliqué** - 5" x 3" (12cm x 8cm) felt remnant

**Beak Appliqué** - 4" x 3" (10cm x 8cm) felt remnant

**Bean Bag Lining** - 7" x 7" (18cm x 18cm) fabric remnant

**Wing Interfacing** - 7" x 13" (18cm x 33cm) fusible fleece remnant

**Paper-backed fusible web** - 4" x 10" (10cm x 25cm) remnant

**Hedgehog C** - 10" L x 5½" H (25cm x 14cm)

45, 60\*\* - ¾ yd. (115, 150cm\* - 0.3m)

**Contrast (Ruffle):** 45, 60\*\* - ¾ yd. (115, 150cm\* - 0.7m)

**Nose Appliqué** - 2" x 2" (5cm x 5cm) felt remnant

**Interfacing (for base)** - 5" x 6" (13cm x 15cm) fusible fleece remnant

\*with nap \*\*without nap

# Simplicity® s3091

Thank you for purchasing this Simplicity pattern. We made every effort to provide you with a high quality product.

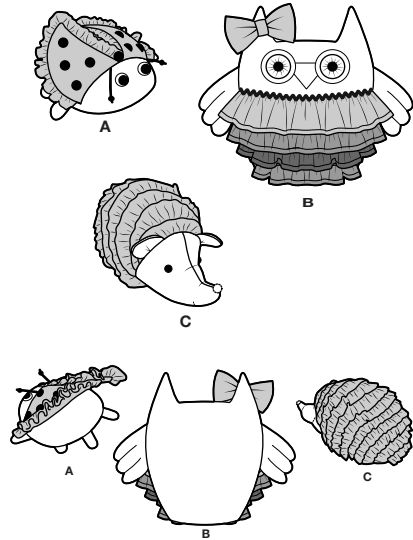

24 PIECES

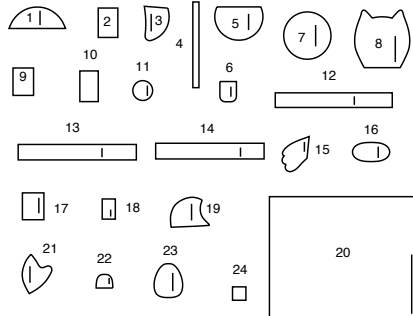

- |                          |                      |
|--------------------------|----------------------|
| 1 HEAD - A               | 13 RUFFLE 3 - B      |
| 2 EYE APPLIQUE - A       | 14 RUFFLE 4 - B      |
| 3 WING - A               | 15 WING - B          |
| 4 WING RUFFLE - A        | 16 BASE - B          |
| 5 TOP - A                | 17 BOW - B           |
| 6 LEG - A                | 18 KNOT - B          |
| 7 BOTTOM - A             | 19 BODY - C          |
| 8 FRONT AND BACK - B     | 20 RUFFLE - C        |
| 9 BEAK APPLIQUE - B      | 21 HEAD - C          |
| 10 EYE BASE APPLIQUE - B | 22 EAR - C           |
| 11 EYE - B               | 23 BOTTOM - C        |
| 12 RUFFLE 1 AND 2 - B    | 24 NOSE APPLIQUE - C |

## Cutting Layouts

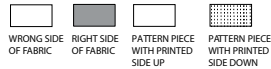

POSITION OF PATTERN PIECES MAY VARY SLIGHTLY ACCORDING TO YOUR PATTERN SIZE

### General Directions For Cutting

**PRE-SHRINK** and iron all fabric.

**FOR DOUBLE THICKNESS** -Fold fabric with RIGHT sides together. Pin pattern to WRONG side of fabric.

**FOR SINGLE THICKNESS** -Pin pattern to RIGHT side of fabric.

★ If layout shows a piece extending past fold, cut out all pieces except piece that extends. Open out fabric to single thickness. Cut extending piece on RIGHT side of fabric in position shown.

✱ Mark small arrows along both selvages in indicating direction of nap or design. Fold fabric crosswise with RIGHT sides together, and cut along fold. Turn one fabric layer around so arrows on both layers go in the same direction. Place RIGHT sides together.

### LADYBUG A

USE PIECES 1 5 6 7

36",45" OR 60" (91CM,115CM, OR 150CM) WITH NAP

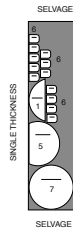

### CONTRAST (WINGS,WINGS RUFFLE)

USE PIECES 3 4

45" OR 60" (115CM OR 150CM) WITH NAP

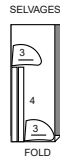

**EYE APPLIQUE** - CUT ONE PIECE 2 FROM FELT AND PAPER BACKED FUSIBLE WEB REMNANTS

### OWL B

USE PIECES 8 11 15 16

45" OR 60" (115CM OR 150CM) WITH NAP

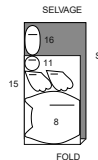

### CONTRAST 1 (RUFFLE 1 AND 2, BOW, KNOT)

USE PIECES 12 18

45" OR 60" (115CM OR 150CM) WITH NAP

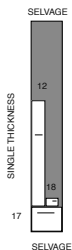

### CONTRAST 2 (RUFFLE 1 AND 2, RUFFLE 4)

USE PIECES 12 14

45" OR 60" (115CM OR 150CM) WITH NAP



### CONTRAST 3 (RUFFLE 3)

USE PIECE 13

45" OR 60" (115CM OR 150CM) WITH NAP

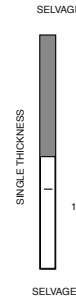

**EYE BASE APPLIQUE** - CUT ONE OF PIECE 10 FROM FELT REMNANT

**BEAK APPLIQUE** - CUT ONE OF PIECE 9 FROM FELT REMNANT

**BEAN BAG LINING** - CUT TWO OF PIECE 16 FROM LINING REMNANT

**WING INTERFACING** - CUT TWO OF PIECE 15 AND ONE OF PIECE 16 FROM FUSIBLE FLEECE REMNANT

**PAPER BACKED FUSIBLE** - CUT ONE EACH OF PIECE 9 10 FROM REMNANT

### HEDGEHOG C

USE PIECES 19 21 22 23

45" OR 60" (115CM OR 150CM) WITH NAP

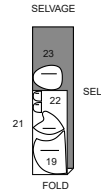

### CONTRAST (RUFFLE)

USE PIECE 20

45" OR 60" (115CM OR 150CM) WITH NAP

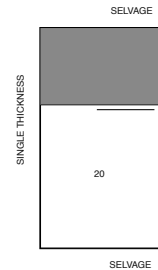

**NOSE APPLIQUE** - CUT ONE OF PIECE 24 OF FELT REMNANT

**INTERFACING (FOR BASE)** - CUT ONE OF PIECE 23 FROM FUSIBLE FLEECE REMNANT

## Sewing Directions

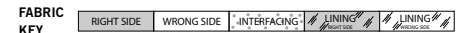

Read **General Directions** before you begin.

Sewing methods in **BOLD TYPE** have Sewing Tutorial Video available. Scan **QR CODE** to watch videos:

**NARROW HEM** - See Hems: "sewing narrow hems" video.

**SLIPSTITCH** - See Hand Stitching: "how to slip stitch" video.

**TRIM SEAM** - See Seams: "how to trim, clip and layer seams" video.

### GLOSSARY OF SEWING METHODS

Sewing methods shown in *ITALICS* are defined below:

**STUFF** - Pull fiberfill apart and fluff it, breaking apart lumps and thick spots. Use pieces about the size of a golf ball. Pack into place using the end of a long handled wooden spoon or chopstick. Pack firmly in place each time stuffing is added. Use both hands to mold and shape, being careful not to over stuff or make lopsided.

### SEWING TUTORIALS



Build your skills viewing short, easy-to-follow videos at [simplicity.com/sewingtutorials](http://simplicity.com/sewingtutorials)

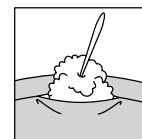

PATTERN PIECES WILL BE IDENTIFIED BY NUMBERS THE FIRST TIME THEY ARE USED.

STITCH 1/4" (6MM) SEAMS WITH RIGHT SIDES TOGETHER UNLESS OTHERWISE STATED.

## LADYBUG A

### PREPARE APPLIQUÉ

- To prepare EYE APPLIQUÉ (2) for application, apply paper backed fusible web to WRONG side of appliqué fabric following manufacturer's directions. Cut appliqué tissue block along outer solid line. Pin pattern to RIGHT side of prepared fabric. Cut out each appliqué.

### APPLY APPLIQUÉ

- Pin prepared eye appliqués to HEAD (1) between the broken lines. Fuse in place following manufacturer's directions.

### CONTINUE WITH LADYBUG AS FOLLOWS

- To make antennae, cut two pieces of 3mm elastic cord 3-1/2" (9cm) long. Knot ends. On OUTSIDE, pin each antenna to head over small dots with raw edges even. Baste in place along seamline.
- To gather upper edge of WING RUFFLE (4), loosen needle tension slightly. On OUTSIDE, stitch 1/4" (6mm) from cut edge using a long stitch. Stitch again 1/8" (3mm) from the first stitching within the seam allowance.
- On OUTSIDE, pin wing ruffle to WING (3) along unnotched edge, pulling up gathering stitches to fit and distributing gathers evenly. Turn under ends of ruffle 1/4" (6mm). Baste ruffle to wing along seamline.
- With RIGHT sides together and raw edges even, pin wing facing to wing. Stitch unnotched edge.
- Turn wing; press, pressing out the ruffle. On OUTSIDE, pin wings to TOP (5), matching small dots, large dots, and notches. Baste.

- With RIGHT sides together and raw edges even, pin head to top, matching notches. Stitch.

- To make each of six legs, with RIGHT sides together and raw edges even, pin two LEG (6) sections. Stitch curved edge. **TRIM SEAM.**

- Turn legs; press. On OUTSIDE, pin each leg to BOTTOM (7) between the sets of small dots. Baste.

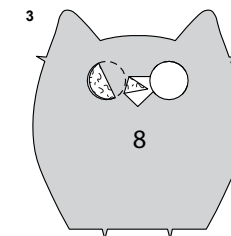
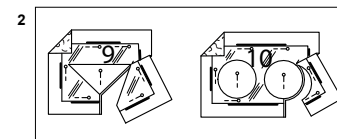
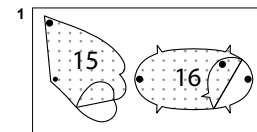
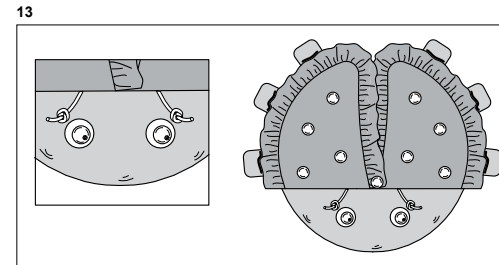
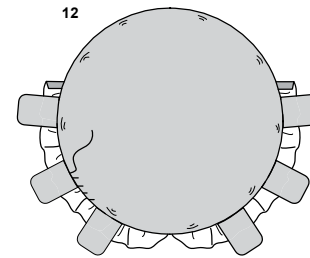
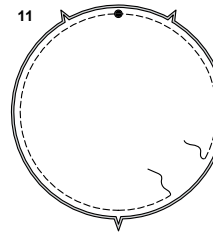
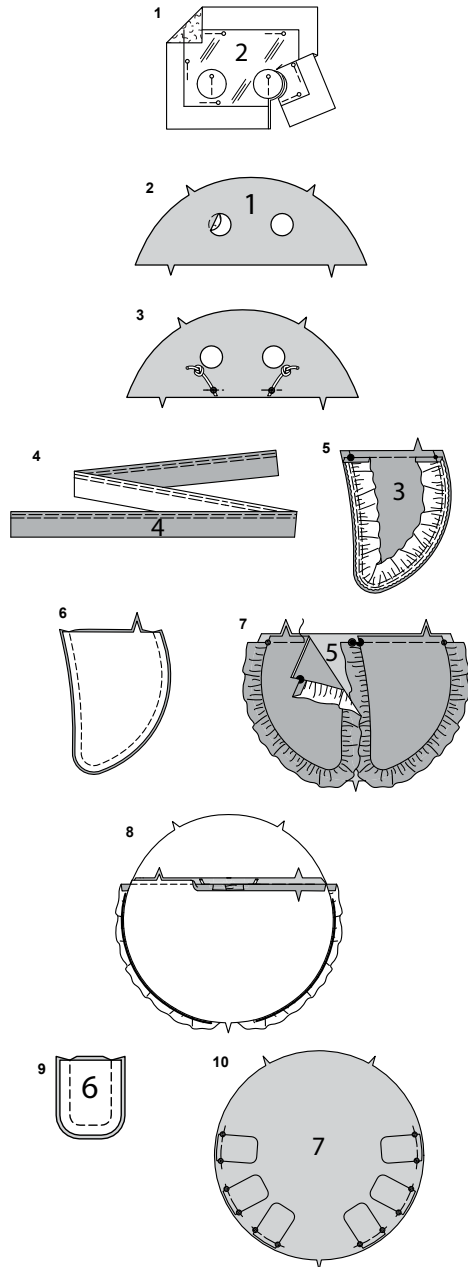

- With RIGHT sides together and raw edges even, pin bottom to head and top, matching large dots and notches. Stitch, leaving an opening for turning. **TRIM SEAM.**

- Turn ladybug; press. **STUFF** ladybug. **SLIPSTITCH** opening closed.

- To make each eye, adhere one 2mm flat backed rhinestone to one 5/8" (1.5cm) flat back gemstone, using a dot of super glue. Using fabric glue, adhere each eye to eye appliqué and remaining nine 5/8" (1.5cm) flat back gemstones to wings, as shown, or as you prefer.

## OWL B

### INTERFACING

- Pin interfacing to WRONG side of WING (15) and BASE (16). Fuse in place following manufacturer's directions.

### PREPARE APPLIQUÉ(S)

- To prepare BEAK APPLIQUÉ (9) and EYE BASE APPLIQUÉ (10) for application, apply paper backed fusible web to WRONG side of appliqué fabric following manufacturer's directions. Cut appliqué tissue block along outer solid line. Pin pattern to RIGHT side of prepared fabric. Cut out each appliqué.

### APPLY APPLIQUÉ

- Pin prepared beak appliqué to one FRONT AND BACK (8) section between the broken lines. Fuse in place following manufacturer's directions. Pin prepared eye base appliqués to front over beak between the broken lines, as shown, and fuse in the same manner.

## CONTINUE WITH OWL AS FOLLOWS

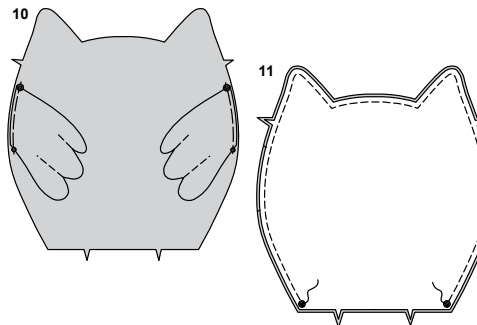
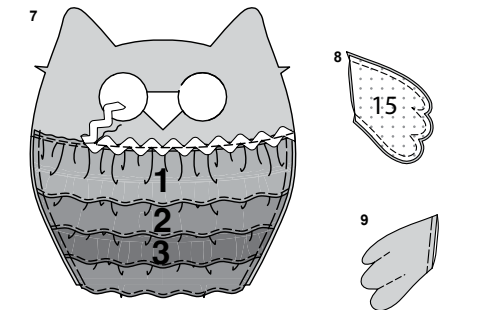
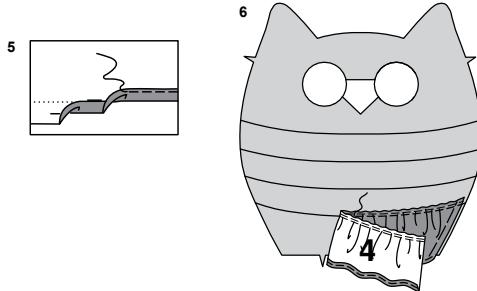
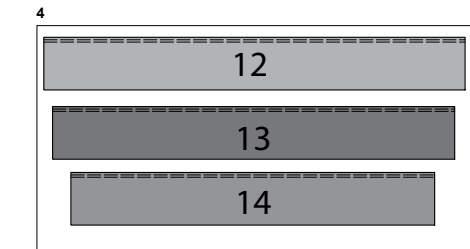

**4.** To gather upper edge of RUFFLE 1 (12), RUFFLE 2 (12), RUFFLE 3 (13), and RUFFLE 4 (14), loosen needle tension slightly. On OUTSIDE, stitch 1/4" (6mm) from cut edge using a long stitch. Stitch again 1/8" (3mm) from the first stitching within the seam allowance.

**5.** Press up 1/2" (1.3cm) on lower edge of ruffles. To form a **NARROW HEM**, tuck under raw edge to meet crease. Press. Stitch hem in place.

**6.** On OUTSIDE, pin ruffle 4 to front placing seamline along lowest placement line, pulling up gathering stitches to fit and distributing gathers evenly. Stitch along seamline. Baste raw ends to front. Pin and stitch remaining ruffles to front in ascending order along corresponding placement lines in the same manner.

**7.** Cut a piece of piece of medium rick rack the length of the upper placement line. On OUTSIDE, pin rick rack to front, placing center along upper raw edge of ruffle. Stitch in place through center of rick rack.

**8.** With RIGHT sides together and raw edges even, pin two WING (15) sections together. Stitch curved edges. **TRIM SEAM.**

**9.** Turn wings; press. Baste raw edges together. Stitch along stitching lines.

**10.** On OUTSIDE, pin wings to remaining front and back section, matching small and large dots. Baste.

**11.** With RIGHT sides together and raw edges even, pin front to back, matching lower large dots and notches. Stitch along curved edges between the large dots, back-stitching at dots to reinforce the seam. **TRIM SEAM.**

**12.** To make a pellet bag for added weight at bottom of owl, pin two BASE (16) lining sections with RIGHT sides together. Baste, leaving about a 1/2" (1.3cm) opening between the back notches.

**13.** Pin pellet bag to WRONG side of fabric BASE (16), matching notches. Baste, leaving an opening between the back notches.

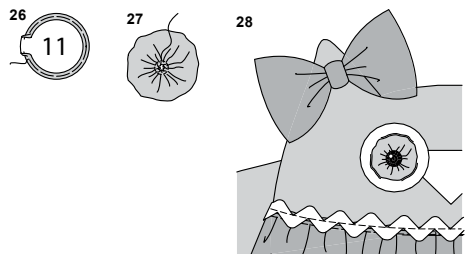
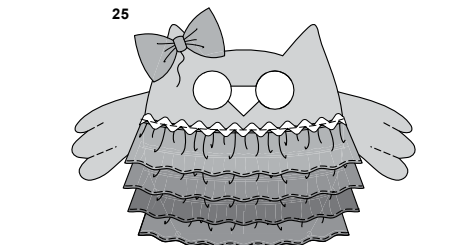
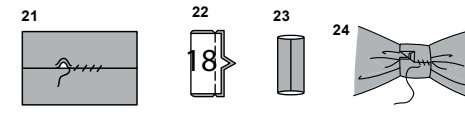
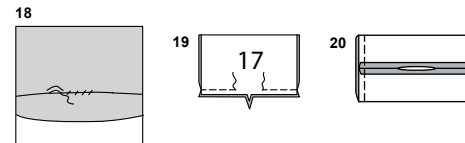
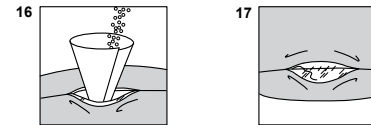
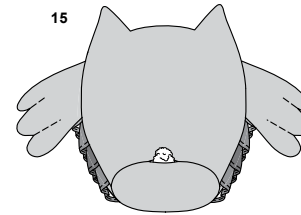

**14.** With RIGHT sides together and raw edges even, pin base to front and back, matching centers, large dots, and notches. Stitch, leaving an opening between the back notches. **TRIM SEAM.**

**15.** Turn owl; press. **STUFF** owl, keeping pellet bag free.

**16.** To fill the pellet bag with plastic pellets, make a paper funnel by rolling up a rectangle of paper. Have a wider opening at the top and a 1/2" (1.3cm) opening at the bottom. Place the small end in the opening (between two layers of lining). Using a small measuring cup, pour the plastic pellets into the top of the funnel, filling the bag.

**17.** **SLIPSTITCH** opening in lining closed.

**18.** On OUTSIDE, **SLIPSTITCH** opening in fabric base closed.

**19.** Fold BOW (17) in half, bringing notched edges together. Stitch notched edge, leaving an opening for turning.

**20.** Bring seam to underside of bow. Stitch across ends.

**21.** Turn bow; press. **SLIPSTITCH** opening closed.

**22.** Fold KNOT (18) in half, lengthwise, with RIGHT sides together. Stitch notched edge.

**23.** Turn knot RIGHT side out, bringing seam to center on UNDERSIDE; press.

**24.** Crush bow at center and place knot around center of bow, turning under and lapping one end on UNDERSIDE. **SLIPSTITCH** ends securely catching in UNDERSIDE of bow.

**25.** On OUTSIDE, pin bow to RIGHT ear and tack or glue in place, as shown on envelope.

**26.** Press under a generous 1/8" (3mm) on outer edge of EYE (11) and hand-gather along broken line, using a small running stitch, if you prefer, finger press under as you sew around the circle.

**27.** Pull up gathering stitches tightly. Fasten thread ends securely.

**28.** On OUTSIDE, tack or glue eye to eye base. Glue one 5/8" (1.5cm) flat back gemstone to center of each eye. Make a mark on each gemstone in white paint to simulate reflected light.

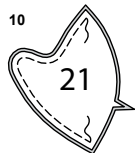
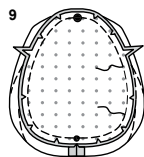
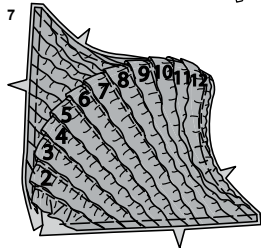
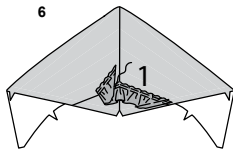
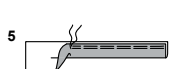
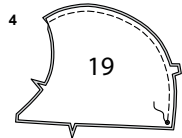
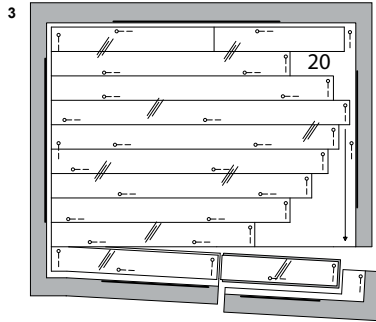
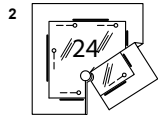
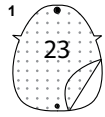

## HEDGEHOG C

### INTERFACING

1. Pin interfacing to **WRONG** side of **BOTTOM** (23). Fuse in place following manufacturer's directions.

### PREPARE APPLIQUÉ AND RUFFLE

2. To prepare **NOSE APPLIQUÉ** (24) for application, cut appliqué tissue block along outer solid line. Pin pattern to **RIGHT** side of fabric. Cut out appliqué.

3. To prepare **RUFFLE** (20) for application, cut tissue block along outer solid line. Pin pattern to **RIGHT** side of fabric. Cut out each ruffle along unmarked solid lines and along cutting lines. Transfer markings to **RIGHT** side of pieces and label each with ruffle number, using a washable fabric marking pen or pencil.

### CONTINUE WITH HEDGEHOG AS FOLLOWS

4. With **RIGHT** sides together and raw edges even, pin **BODY** (19) sections. Stitch double notched (back) edge from neck edge to small dot, back-stitching at dot to reinforce the seam. **TRIM SEAM.**

5. Fold ruffles in half along foldlines with **WRONG** sides together. Press. To gather upper edge of each, loosen needle tension slightly. On **OUTSIDE**, stitch 1/4" (6mm) from cut edge using a long stitch. Stitch again 1/8" (3mm) from the first stitching within the seam allowance.

6. On **OUTSIDE**, pin ruffle 1 to body placing seamline along lowest placement line, pulling up gathering stitches to fit and distributing gathers evenly. Stitch along seamline. Baste raw edges together.

7. Pin and stitch remaining ruffles to body in ascending order along corresponding placement lines in the same manner. Baste raw edges together.

8. Machine-stitch along seamline of **BOTTOM** (23). Clip seam allowance to stitching, being careful not to clip through stitching.

9. With **RIGHT** sides together and raw edges even, pin bottom to body, matching small dots, large dots, and notches. Stitch, leaving a 2" (5cm) opening in one side edge for turning. **TRIM SEAM.**

10. With **RIGHT** sides together and raw edges even, pin two **HEAD** (21) sections. Stitch unnotched edge between the seam allowances, back-stitching at ends to reinforce the seam. **TRIM SEAM.**

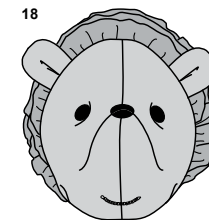
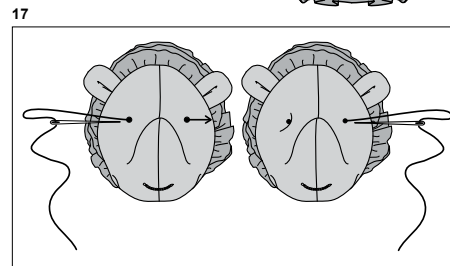
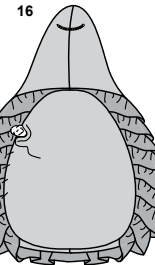
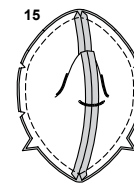
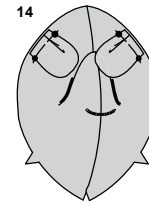
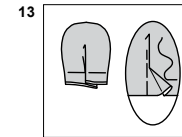
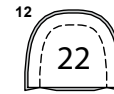
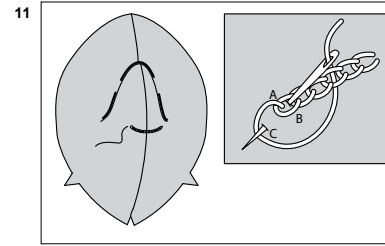

11. Open out the head; press. On **OUTSIDE**, using six strands of embroidery floss, stitch along solid line for mouth with a chain stitch.

To chain stitch, bring the needle to the **RIGHT** side of the fabric on the transferred design line (A). Make a small loop with the thread and hold it in place with your **LEFT** thumb. Insert the needle back close to where the thread first came up (B). Bring the needle out a little to the **LEFT**, over the thread loop (C).

12. To make each ear, pin two **EAR** (22) sections with **RIGHT** sides together. Stitch curved edge. **TRIM SEAM.**

13. Turn ear; press. Baste raw edges together. To make a pleat, fold ear along solid line, bring fold to broken line. Baste along seamline.

14. On **OUTSIDE**, pin ears to head, matching small and large dots. Baste.

15. With **RIGHT** sides together and raw edges even, pin head to body, matching seams and notches, clipping seam allowance as necessary. Stitch. **TRIM SEAM.**

16. Turn hedgehog through opening in body; press. **STUFF**. **SLIPSTITCH** opening closed.

17. To make hollows for eyes, thread a needle and take a small stitch through one small dot on face. Bring the needle through the stuffed face to the **INSIDE**, and back to the **OUTSIDE** at the remaining small dot. Make a small stitch and pull thread taut, making hollows at the eyes. Knot end, invisibly.

18. To make eyes, adhere 3/8" (1cm) flat backed gemstones to head over small dots, using fabric glue. Glue nose appliqué to face at remaining small dot.



# Congrats!

You've completed your sewing adventure

---

## SHARE YOUR LOOK



Post your pattern and tag us using [#simplicitypatterns](#)  
[@simplicity creative group](#)  
[@simplicitymccallsuk](#)  
[@simplicitymccallsaustralia](#)  
for a chance to be featured on our social media.

Look for more PDF patterns at [simplicity.com](#) or for customers outside the U.S. and Canada visit [sewdirect.com](#) and [sewdirect.com.au](#)

Have a question or need help with your sewing project contact us:  
[Simplicity.com](#)    [Sewdirect.com](#)    [Sewdirect.com.au](#)



Simplicity ©2024 a division of IG Design Group Americas Inc. • Atlanta, GA 30342 USA [www.thedesigngroup.com](#) • All Rights Reserved. [www.simplicity.com](#) • Made in the U.S.A. Fabriqué aux États-Unis.

To be used for individual private home use only and not for commercial or manufacturing purposes. • A usage privé seulement et non à des fins commerciales ou de production en série. • Para uso privado solamente, no se puede utilizar con propósitos de comercialización o de producción en serie.