

S3087

**Simplicity**<sup>®</sup>



Designed and printed in USA.

easy-to-sew

Shop all the pattern brands you love at

**Simplicity**<sup>®</sup>.com

For customers outside of the U.S. and Canada

sewdirect.com

sewdirect.com.au

**BODY MEASUREMENTS**

Size	S (8-10)	M (12-14)	L (16-18)	Inc.
Bust	33 1/2-35 1/2 (86-89)	36-38 (91-97)	39-41 (99-105)	1/2" (1cm)
Waist	24-25 (61-64)	26 1/2-28 (67-71)	30-32 (76-81)	1/2" (1cm)
Hip 8" below waist	33 1/2-34 1/2 (85-88)	36-38 (91-97)	40-42 (102-107)	1/2" (1cm)
Back-neck to waist	15 1/2-16 (40-40.5)	16 1/4-16 1/2 (41.5-42)	16 1/2-17 (42.5-43)	1/2" (1cm)

Very Easy

**APRONS IN SIZES S-M-L AND KITCHEN ACCESSORIES**

**Suggested Fabrics:** Broadcloth, Canvas, Chintz, Cotton Types, Ticking, Twill. **Towels D,E** also in Terry Cloth. **Appliqués A** also in Fleece, Nylon Spandex Fabrics, Satin. **Lining:** Muslin. **Interfacing A,B:** Lightweight Fusible. **Interfacing E,F:** Fusible Fleece. **Batting F:** Heat Resistant Cotton Batting.  
**Notions:** **A,B:** Five 7/8" (2.2cm) buttons, one pkg. of 1/4" (6mm) double fold bias tape. **C:** One pkg. of 1/4" (6mm) double fold bias tape. **F:** Two pkgs. of 1/2" (1.3cm) double fold bias tape.

Sizes	S	M	L	Yd. m
<b>Apron A</b>	45" - 7/8 yd. (115cm - 0.8m)			
<b>Contrast 1 (Strap, Waistband, Tie End)</b>	45"*	3/4	7/8	
	115cm*	0.7	0.7	
<b>Contrast 2 (Lower Band)</b>	45"* - 1/4 yd. (115cm - 0.2m)			
<b>Lining</b>	45"* - 1/4 yd. (115cm - 0.2m)			
<b>Interfacing</b>	20" - 1 yd. (51cm - 0.9m)			
<b>Paper-backed Fusible Web:</b>	17" - 3/8 yd. (43cm - 0.3m)			

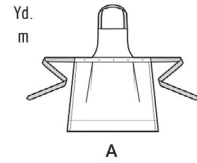

**Appliqués A**  
**Upper and Lower Bun Appliqués** - 6" x 7" (15cm x 18cm) remnant  
**Lettuce Appliqué** - 2" x 6" (5cm x 15cm) remnant  
**Burger Appliqué** - 3" x 6" (8cm x 15cm) remnant  
**Tomato Appliqué** - 3" x 4" (8cm x 10cm) remnant  
**Cheese Appliqué** - 4" x 6" (10cm x 15cm) remnant

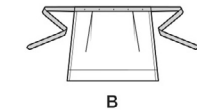

**Apron B** 45" - 7/8 yd. (115cm - 0.8m)  
**Contrast (Lower Band, Waistband, Tie End)**  
 45"\* - 3/8 yd. (115cm - 0.6m)  
**Lining** 45"\* - 7/8 yd. (115cm - 0.8m)  
**Interfacing** 20" - 1 yd. (51cm - 0.9m)



**Pocket Panel C (One Size)**  
 45"\* - 3/8 yd. (43cm - 0.6m)  
**Contrast (Pocket, Band):**  
 45"\* - 3/8 yd. (43cm - 0.4m)  
**Lining:** 8" x 15" (20cm x 38cm) remnant



**Towel E (One Size)**  
 45"\* - 3/8 yd. (115cm - 0.6m)  
**Contrast (Header):** 9" x 14" (23cm x 36cm) remnant



**Towel D (One Size)**  
 45"\* - 3/4 yd. (43cm - 0.7m)  
**Contrast (Band)**  
 45"\* - 1/4 yd. (115cm - 0.2m)

**Oven Mitt F (One Size)**  
 45"\* - 1/2 yd. (0.5m)  
**Contrast 1 (Band)** - Purchase same amount as for Oven Mitt  
**Contrast 2 (Pocket):** 45"\* - 3/8 yd. (43cm - 0.4m)  
**Lining:** Purchase same amount as for Contrast 2 (Pocket)  
**Batting:** 45" - 1/2 yd. (0.5m)  
**Interfacing:** 45" - 7/8 yd. (115cm - 0.8m)



\*with nap \*\*without nap

# Simplicity®

Thank you for purchasing this Simplicity pattern. We made every effort to provide you with a high quality product.

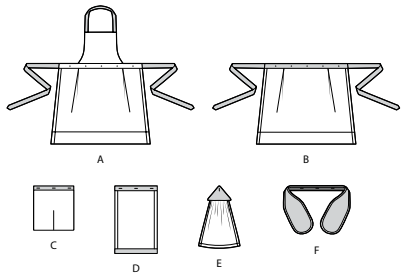
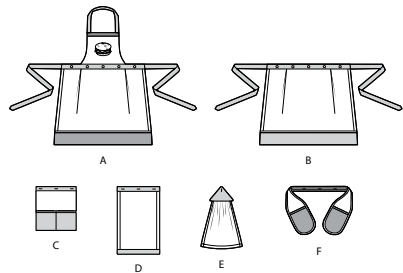

22 PIECES

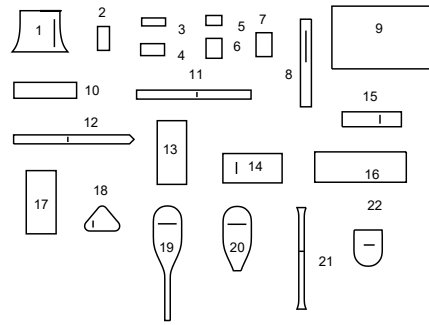

- 1 BIB - A
- 2 LOWER BUN APPLIQUE - A
- 3 LETTUCE APPLIQUE - A
- 4 BURGER APPLIQUE - A
- 5 TOMATO APPLIQUE - A
- 6 CHEESE APPLIQUE - A
- 7 UPPER BUN APPLIQUE - A
- 8 STRAP - A,B
- 9 APRON - A,B
- 10 LOWER BAND - A,B
- 11 WAISTBAND - A,B
- 12 TIE END - A,B
- 13 POCKET PANEL - C
- 14 POCKET - C
- 15 BAND - C,D
- 16 TOWEL - D
- 17 TOWEL - E
- 18 HEADER - E
- 19 OVEN MITT - F
- 20 OVEN MITT BATTING - F
- 21 OVEN MITT INTERFACING - F
- 22 POCKET - F

## General Directions

### The Pattern

- SYMBOLS**
- GRAIN LINE Place on straight grain of fabric parallel to selvage
  - PLACE SOLID LINE on fold of fabric.
  - CENTER FRONT OR BACK OF garment.
  - NOTCHES
  - DOTS
  - CUTTING LINE
  - LENGTHEN OR SHORTEN LINES

SEAM ALLOWANCE: 5/8" (1.5cm) unless otherwise stated is included but not printed on MULTI-SIZE PATTERNS. Mark your size with colored felt tip pen. See chart on tissue for how to use MULTI-SIZE PATTERNS.

**ADJUST IF NEEDED**  
Make adjustments before placing pattern on fabric.

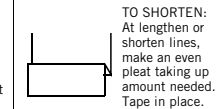
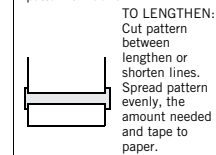

When lengthen or shorten lines are not given, make adjustments at lower edge of pattern.

### Cutting/Marking

**BEFORE CUTTING:**  
PRESS pattern pieces with a warm dry iron. PRE-SHRINK fabric by pre-washing washables or steam-pressing non-washables.

CIRCLE your cutting layout.  
PIN pattern to fabric as shown in Cutting Layouts.

- FOR DOUBLE THICKNESS: Fold fabric with RIGHT sides together.
- FOR SINGLE THICKNESS: Place fabric RIGHT side up.
- FOR PILE, SHADED OR ONE WAY DESIGN FABRICS: Use "with nap" layouts

**AFTER CUTTING:**  
Transfer markings to WRONG side of fabric before removing pattern. Use pin and chalk method or dressmaker's tracing paper and wheel.

**To Quick Mark:**

- Snip edge of fabric to mark notches, ends of fold lines and center lines.
- Pin mark dots.

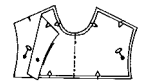

### Sewing

- SEW garment following Sewing Directions.
- PIN or machine-baste seams matching notches.
- STITCH 5/8" (1.5 cm) seams unless otherwise stated.
- PRESS seams open unless otherwise indicated clipping when necessary so seams will lie flat.
- TRIM seams to reduce bulk, as shown below.

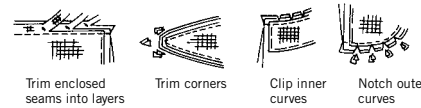

### SPECIAL CUTTING NOTES

★ If layout shows a piece extending past fold, cut out all pieces except piece that extends.

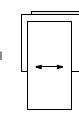

Open out fabric to single thickness. Cut extending piece on RIGHT side of fabric in position shown.

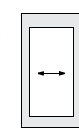

✱ Mark small arrows along both selvages indicating direction of nap or design. Fold fabric crosswise with RIGHT sides together, and cut along fold (a).

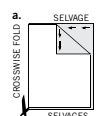

Turn one fabric layer around so arrows on both layers go in the same direction. Place RIGHT sides together (b).

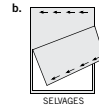

## Cutting Layouts

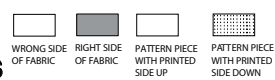

POSITION OF PATTERN PIECES MAY VARY SLIGHTLY ACCORDING TO YOUR PATTERN SIZE

### A,B APRON USE PIECE 9

45" (115CM)  
WITH NAP  
ALL SIZES

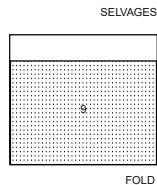

### A,B INTERFACING USE PIECE 11

20" (51CM)  
ALL SIZES

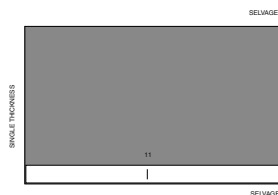

### A CONTRAST 1 (STRAP, WAISTBAND, TIE END) USE PIECES 8 11 12

45" (115CM)  
WITH NAP  
ALL SIZES

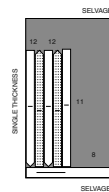

### A CONTRAST 2 (LOWER BAND) USE PIECE 10

45" (115CM)  
WITH NAP  
ALL SIZES

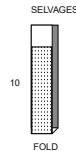

### A LINING USE PIECE 11

45" (115CM)  
WITHOUT NAP  
ALL SIZES

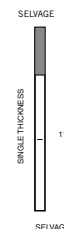

### A PAPER BACKED FUSIBLE WEB USE PIECE 2 4 5 7

17" (43CM)  
ALL SIZES



**A APPLIQUES:**  
UPPER AND LOWER BUN APPLIQUES - CUT ONE EACH OF PIECE 2 7 FROM REMNANT.  
LETTUCE APPLIQUE - CUT ONE OF PIECE 3 FROM REMNANT.  
BURGER APPLIQUE - CUT ONE OF PIECE 4 FROM REMNANT.  
TOMATO APPLIQUE - CUT ONE OF PIECE 5 FROM REMNANT.  
CHEESE APPLIQUE - CUT ONE OF PIECE 6 FROM REMNANT.

### B CONTRAST (LOWER BAND, WAISTBAND, TIE END) USE PIECES 10 11 12

45" (115CM)  
WITH NAP  
ALL SIZES

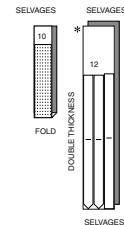

### B LINING USE PIECE 9

45" (115CM)  
WITHOUT NAP  
ALL SIZES

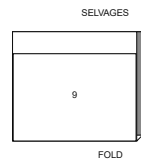

### C POCKET PANEL (ONE SIZE) USE PIECE 13

45" (115CM)  
WITH NAP  
ALL SIZES

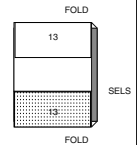

### C CONTRAST (POCKET, BAND) USE PIECES 14 15

45" (115CM)  
WITH NAP  
ALL SIZES

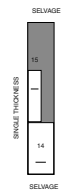

### C LINING CUT ONE OF PIECE 14 FROM REMNANT

# S3087

2 of 5

## D TOWEL (ONE SIZE)

USE PIECE 16

45" (115CM)  
WITH NAP

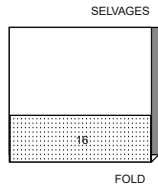

## E TOWEL (ONE SIZE)

USE PIECE 17

45" (115CM)  
WITH NAP

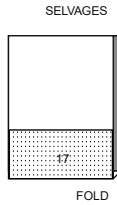

## E CONTRAST (HEADER)

CUT TWO OF PIECE 18 FROM REMNANT

## F OVEN MITT (ONE SIZE)

USE PIECE 19

45" (115CM)  
WITH NAP

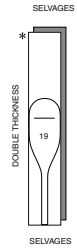

## F CONTRAST 1

FOLLOW SAME LAYOUT AS FOR OVEN MITT

## F CONTRAST 2 (POCKET)

USE PIECE 22

45" (115CM)  
WITH NAP

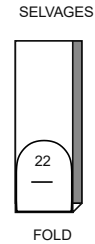

## F BATTING

USE PIECES 20 22

45" (115CM)

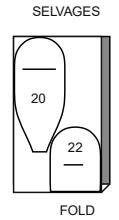

## F INTERFACING

USE PIECES 21 22

45" (115CM)

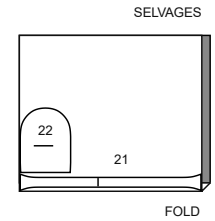

## D CONTRAST (BAND)

USE PIECE 15

45" (115CM)  
WITH NAP

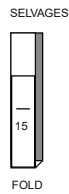

## F LINING

FOLLOW SAME LAYOUT AS FOR CONTRAST 2

SEWING TUTORIALS



Build your skills viewing short, easy-to-follow videos at [simplicity.com/sewingtutorials](http://simplicity.com/sewingtutorials)

## Sewing Directions

**FABRIC KEY** RIGHT SIDE WRONG SIDE INTERFACING LINING LINING

Read **General Directions** on page 1 before you begin.

Sewing methods in **BOLD TYPE** have Sewing Tutorial Video available. Scan QR CODE to watch videos:

**EDGESTITCH** – See **Machine Stitches: "how to sew an edgestitch"** video.

**TOPSTITCH** – See **Machine Stitches: "how to topstitch"** video.

**TRIM SEAM** – See **Seams: "how to trim, clip and layer seams"** video.

**PATTERN PIECES WILL BE IDENTIFIED BY NUMBERS THE FIRST TIME THEY ARE USED.**

**STITCH 3/8" (1CM) SEAMS WITH RIGHT SIDES TOGETHER UNLESS OTHERWISE STATED.**

### APRON A, B

#### INTERFACING

1. Pin interfacing to **WRONG** side of **WAISTBAND** (11). Fuse in place following manufacturer's directions.

#### BIB A

2. To prepare **LOWER BUN APPLIQUÉ** (2), **BURGER APPLIQUÉ** (4), **TOMATO APPLIQUÉ** (5), and **UPPER BUN APPLIQUÉ** (7), apply paper backed fusible web to **WRONG** side of appliqué fabric following manufacturer's directions. Cut appliqué fabric along outer solid line. Pin pattern to **RIGHT** side of prepared fabric. Cut out each appliqué. Transfer markings to **RIGHT** side of appliqué using a washable fabric marking pen or pencil. **LOWER BUN APPLIQUÉ** is shown.

3. Prepare **LETTUCE APPLIQUÉ** (3) and **CHEESE APPLIQUÉ** (6) in the same manner, omitting paper backed fusing web. With **RIGHT** sides together, fold cheese appliqué along foldline. Stitch notched edge. **TRIM SEAM.**

4. Turn cheese appliqué; press. Baste raw edges together.

5

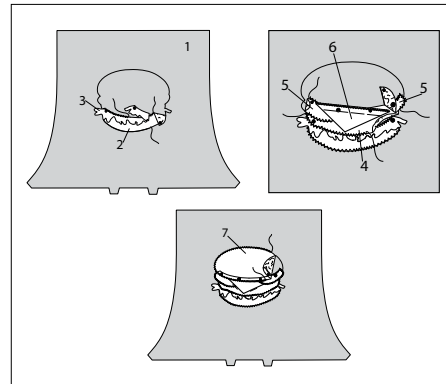

5. Apply appliqués to **BIB** (1) in ascending order, (except for the tomato appliqués which sandwich the cheese appliqué), along the solid line, matching small dots, beginning with lower bun appliqué (2). Fuse fusible appliqués in place, following manufacturer's directions. Zigzag stitch or straight stitch close to fused appliqué edges, leaving lettuce and cheese appliqué edges loose, as shown.

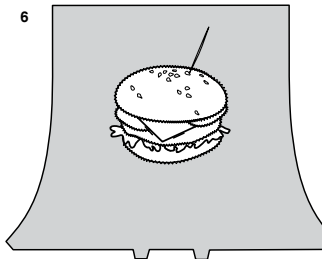

6. With a toothpick, apply small daubs of a light-colored fabric paint on top of upper bun to create "sesame seeds". Allow paint to dry completely before proceeding.

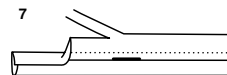

7. Cut a piece of 1/4" (6mm) double fold bias tape the length of the placement line. Open out the center fold of the tape. Trim one edge of tape 1/8" (3mm) from center fold and discard, leaving a 1/4" (6mm) wide strip with turned under edges. Press.

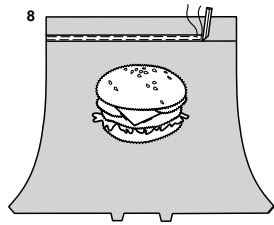

**8.** Pin tape to bib with inner edge of tape along placement line. **EDGESTITCH** close to both long edges of tape.



**9.** Fold STRAP (8) in half, lengthwise with **RIGHT** sides together. Stitch. **TRIM SEAM.**

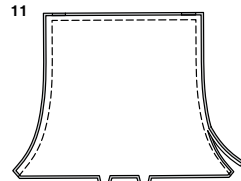
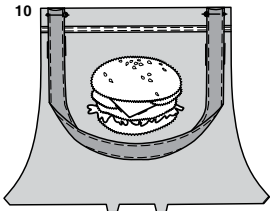

**10.** Turn strap; press. **EDGESTITCH** close to long edges. On **OUTSIDE**, pin strap to bib, matching small and large dots. Baste.

**11.** With **RIGHT** sides together and raw edges even, pin bib facing to bib. Stitch unnotched edges. **TRIM SEAM.**

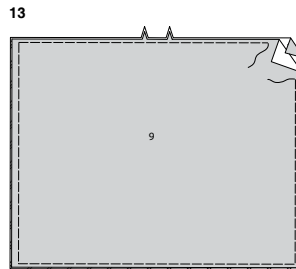
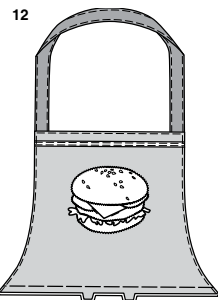

**12.** Turn bib; press, pressing out the strap. **EDGESTITCH** bib close to finished edges; baste raw edges together.

#### APRON LINING B

**13.** Pin APRON (9) to apron lining with **WRONG** sides together. Baste along seam allowance.

#### CONTINUE AS FOLLOWS FOR BOTH VIEWS

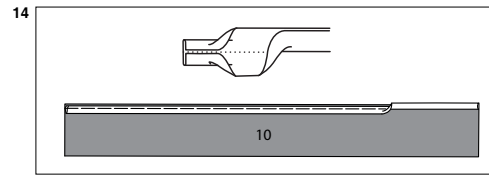

**14.** Cut a piece of 1/4" (6mm) double fold bias tape the length of the LOWER BAND (10). Open out inner folds; press. On **OUTSIDE**, pin bias strip to upper edge of lower band, placing fold 1/4" (6mm) from seamline and raw edges within the seam allowance. Baste along seamline. Turn under seam allowance along basting; press, pressing out the tape.

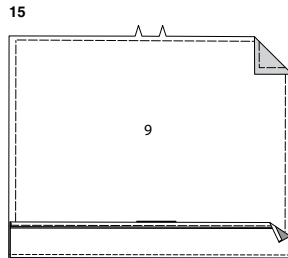

**15.** Pin **RIGHT** side of band to **WRONG** side of APRON (9) along lower edge. Stitch lower edge. **TRIM SEAM.**

**16.** Turn band to **OUTSIDE**; press. Baste raw edges together. On **OUTSIDE**, **TOPSTITCH** 1/8" (3mm) from lower edge of band, and **EDGESTITCH** close to upper edge of band, keeping bias tape fold free.

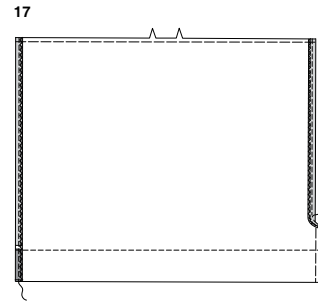

**17.** Stitch 1/4" (6mm) from raw side edges of apron and finish with zigzag stitches or overlock stitches. Turn under 3/4" (2cm) hem allowance on side edges of apron; press. Stitch in place 1/2" (1.3cm) from pressed edge.

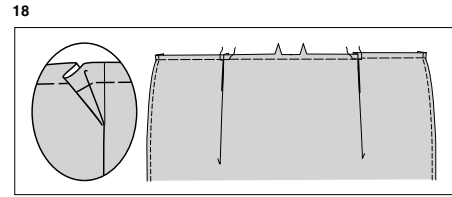

**18.** To make pleats, on **OUTSIDE**, fold along solid lines. Bring folds to broken lines; pin. Baste across raw edge.

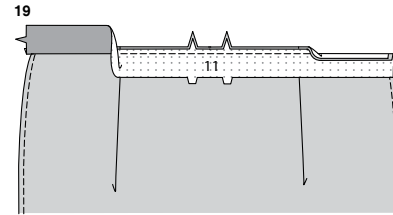

**19.** With **RIGHT** sides together and raw edges even, pin WAISTBAND (11) to apron, matching notches. Stitch. Press seam toward waistband, pressing waistband out.

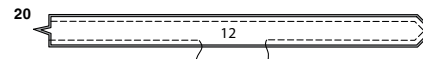

**20.** To make two ties, pin two TIE END (12) sections with **RIGHT** sides together. Stitch unnotched edges, leaving an opening in one long edge for turning.



**21.** Turn tie; press, pressing under opening edges. **EDGESTITCH** close to finished edges. Baste notched edges together.

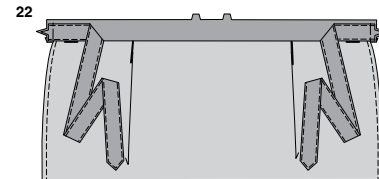

**22.** On **OUTSIDE**, pin ties to ends of waistband, matching notches. Baste.

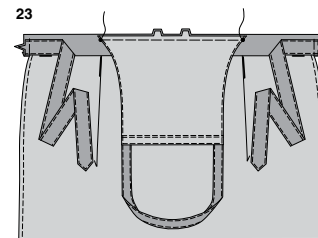

**23. FOR VIEW A** – With **RIGHT** sides together and raw edges even, pin lower edge of bib to upper edge of waistband matching large dots and notches. Baste, being careful not to catch in finished edges of ties.

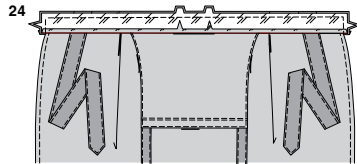

25

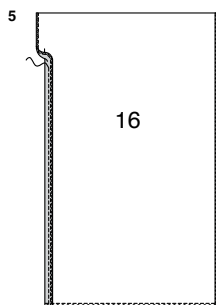
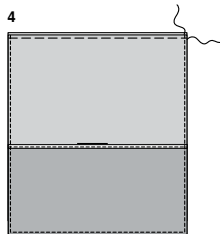
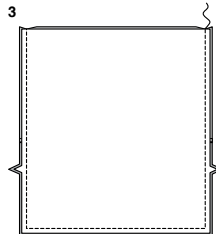
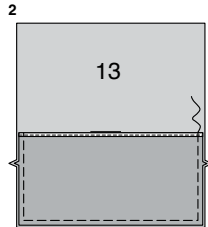
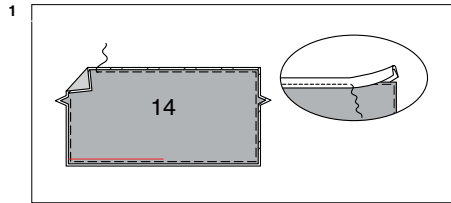
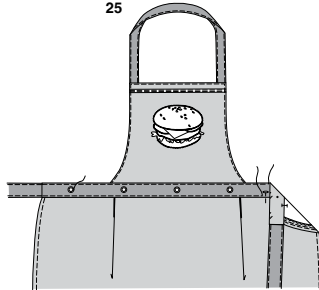

**24. FOR BOTH VIEWS** – Press under 3/8" (1cm) seam allowance on lower edge of waistband lining/facing. On OUTSIDE, pin facing to waistband with raw edges even, matching notches. Stitch upper edge and ends, being careful not to catch in finished edges of ties. **TRIM SEAM.**

**25.** Turn waistband lining/facing to the INSIDE; press, pressing out ties, and bib for View A. On INSIDE, pin pressed edge of lining/facing over seam, placing pins on OUTSIDE. On OUTSIDE, **EDGESTITCH** waistband close to seam, catching in pressed edge of lining/facing on the INSIDE. **EDGESTITCH** close to upper edge of waistband. Sew 7/8" (2.5cm) buttons to waistband at small dots.

## POCKET PANEL C, TOWEL D

### POCKET PANEL C

**1.** Pin POCKET (14) to pocket lining with WRONG sides together. Baste 1/8" (3mm) from raw edges. Cut a piece of 1/4" (6mm) double fold bias tape the length of the upper edge of pocket. To finish upper edge of pocket, slip the pocket between the folds of the bias tape placing the raw edge against the center crease and the wider folded edge of the tape on the INSIDE of the pocket. Stitch the tape in place from the OUTSIDE, being sure to catch in the folded edge on the INSIDE.

**2.** On OUTSIDE, pin pocket to POCKET PANEL (13), matching notches and having raw edges even. Baste along seamline.

**3.** With RIGHT sides together and raw edges even, pin pocket panel to facing. Stitch side and lower edges. **TRIM SEAM.**

**4.** Turn pocket panel; press. **EDGESTITCH** close to finished edges. Baste 1/4" (6mm) from upper edges.

### TOWEL D

**5.** Stitch 1/4" (6mm) from raw side edges of TOWEL (16) and finish with zigzag stitches or overlock stitches. Turn under 5/8" (1.5cm) hem allowance on side edges of towel; press. Stitch in place 1/2" (1.3cm) from pressed edge.

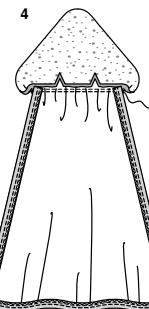
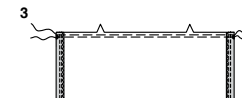
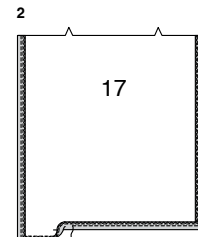
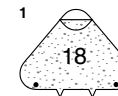
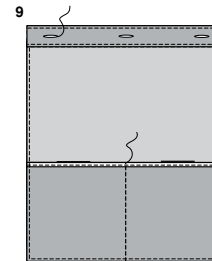
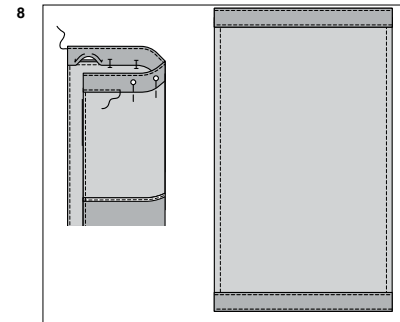
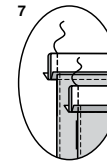
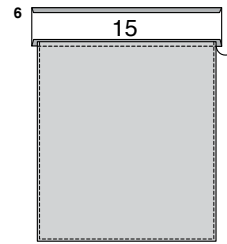

## CONTINUE AS FOLLOWS FOR BOTH VIEWS

**6.** Press under 3/8" (1cm) on upper edge of BAND (15). With RIGHT sides together and raw edges even, pin band to upper edge of pocket panel or towel. Stitch. Press seam toward band, pressing band out. **TRIM SEAM.**

**7.** Fold band along foldline with RIGHT sides together. Stitch ends. **TRIM SEAM.**

**8.** Turn band; press. On INSIDE, pin pressed edge of band over seam, placing pins on OUTSIDE. On OUTSIDE, **EDGESTITCH** band close to seam, catching in pressed edge of facing on the INSIDE. **TOPSTITCH** 1/8" (3mm) from long outer edge of band.  
**FOR VIEW D** – Stitch second band to lower edge of towel in the same manner.

**9.** Make buttonholes in upper band at markings for View D. Stitch along stitching line on pocket.

## TOWEL E

### INTERFACING

**1.** Pin fusible fleece interfacing to WRONG side of HEADER (18) and header facing. Fuse in place following manufacturer's directions.

### TOWEL AND HEADER

**2.** Stitch 1/4" (6mm) from side and lower edges of TOWEL (17) and finish with zigzag stitches or overlock stitches. Turn under 1/2" (1.3cm) hem allowance on side edges of towel; press. Stitch in place 1/2" (1.3cm) from pressed edge.

**3.** To gather upper edge of towel between the small dots, stitch 3/8" (1.3cm) from cut edge using a long stitch. Stitch again 1/8" (3mm) from the first stitching within the seam allowance.

**4.** With RIGHT sides together and raw edges even, pin upper edge of towel to lower edge of header, matching small dots and notches, pulling up gathering stitches to fit. Stitch between the small dots, back-stitching at dots to reinforce the seam. Press seam toward header, pressing header out.

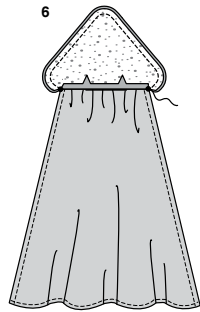
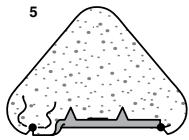

5. To reinforce header facing at the small dots, stitch along seam line for about 1/2" (1.3cm) each side of the small dots, stitching through the dots, as shown. Clip to stitching at the dots. Turn under clipped edge between the dots. Press.

6. With RIGHT sides together and raw edges even, pin facing to header, matching small dots. Stitch outer edges between the dots, back-stitching at dots to reinforce the seam. **TRIM SEAM.**

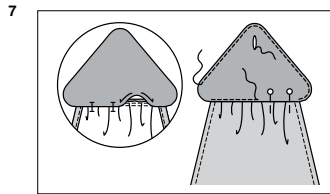

7. Turn header; press. On INSIDE, pin pressed edge of header over seam, placing pins on OUTSIDE. On OUTSIDE, **EDGESTITCH** header close to seam, catching in pressed edge of facing on the INSIDE. **EDGESTITCH** remaining finished edges of header. Make buttonhole at marking.

## OVEN MITT F

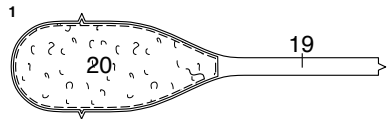

1. Pin OVEN MITT BATTING (20) to WRONG side of OVEN MITT (19). Baste 1/8" (3mm) from raw edges.

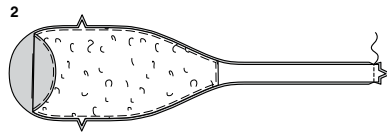

2. Stitch oven mitt sections together at notched ends.

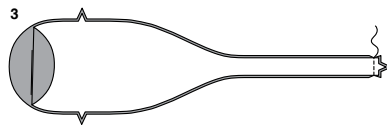

3. Stitch oven mitt contrast lining sections together at notched ends.

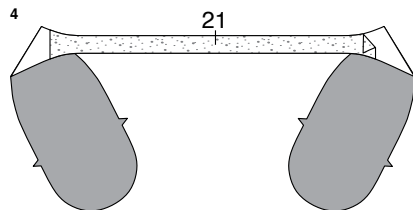

4. Pin OVEN MITT INTERFACING (21) to oven mitt contrast lining. Fuse in place following manufacturer's directions.

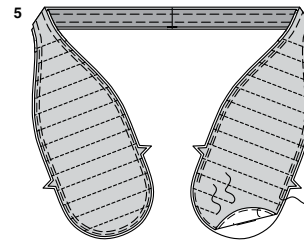

5. Pin oven mitt to oven mitt lining with WRONG sides together and raw edges even, matching seams and notches. Stitch along stitching lines. Baste 3/8" (1cm) from raw edges.

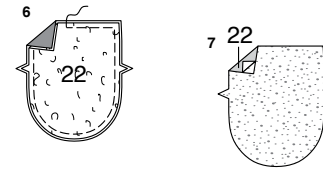

6. Pin pocket batting to WRONG side of POCKET (22). Baste 1/8" (3mm) from raw edges.

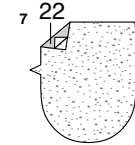

7. Pin fleece interfacing to WRONG side of POCKET (22) lining. Fuse in place following manufacturer's directions.

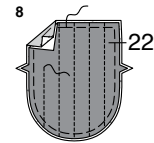

8. Pin pocket to pocket lining with WRONG sides together and raw edges even, matching notches. Stitch along stitching lines. Baste 3/8" (1cm) from raw edges.

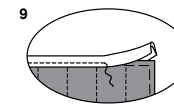

9. Cut a piece of 1/2" (1.3cm) double fold bias tape the length of the upper edge of pocket. To finish upper edge of pocket, slip the pocket between the folds of the bias tape placing the raw edge against the center crease and the wider folded edge of the tape on the INSIDE of the pocket. Stitch the tape in place from the OUTSIDE, using a 1/8" (3mm) wide zigzag stitch or 1/8" (3mm) wide stretch stitch or a straight stitch, being sure to catch in the folded edge on the INSIDE.

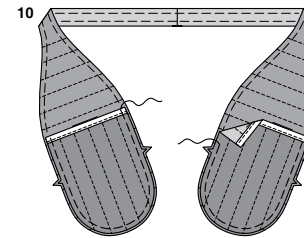

10. Pin pocket to oven mitt with lining sides together, matching notches. Baste 3/8" (1cm) from raw edges.

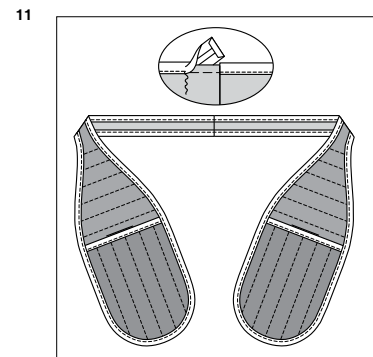

11. Cut a piece of binding the length of the outer edge of mitt, plus 1/2" (1.3cm). Open out the ends and turn under 1/4" (6mm) on each. Pin binding to outer edge of mitt in the same manner as pocket, having ends meet at center seam. Stitch in the same manner as pocket.

**TIP:** To apply binding to curved sections, pre-shape it with a steam iron by stretching the single fold edge and pressing.

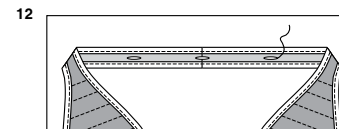

12. Make buttonholes at markings.



# Congrats!

You've completed your sewing adventure

---

## SHARE YOUR LOOK



Post your pattern and tag us using [#simplicitypatterns](#)  
[@simplicity\\_creative\\_group](#)  
[@simplicitymccallsuk](#)  
[@simplicitymccallsaustralia](#)  
for a chance to be featured on our social media.

Look for more PDF patterns at [simplicity.com](#) or for customers outside the U.S. and Canada visit [sewdirect.com](#) and [sewdirect.com.au](#)

Have a question or need help with your sewing project contact us:  
[Simplicity.com](#)    [Sewdirect.com](#)    [Sewdirect.com.au](#)



Simplicity ©2024 a division of IG Design Group Americas Inc. • Atlanta, GA 30342 USA [www.thedesigngroup.com](#) • All Rights Reserved. [www.simplicity.com](#) • Made in the U.S.A. Fabriqué aux États-Unis.

To be used for individual private home use only and not for commercial or manufacturing purposes. • A usage privé seulement et non à des fins commerciales ou de production en série. • Para uso privado solamente, no se puede utilizar con propósitos de comercialización o de producción en serie.