

S3058

Simplicity[®]



easy-to-sew

Shop all the pattern brands you love @

Simplicity[®].com

Very Easy

APRON IN ONE SIZE AND KITCHEN ACCESSORIES

Suggested Fabrics: A,B,C,D,E in Cotton Types, Linen Types. A,C,D,E also in Chintz, Denim, Twill. B also in Terry Cloth. F,G,H,I,J in Laminates. **Batting:** Heat-Resistant Cotton Batting.

Notions: C,D,E: One pkg. of ½" (1.3cm) double fold bias tape. F,G: ¼" (6mm) elastic: ¾ yd. (0.8m) for F, ¾ yd. (0.6m) for G. H,I,J: ¼" (6mm) elastic: ¾ yd. (0.7m) for H, ¾ yd. (0.6m) for I, ¾ yd. (0.6m) for J, one pkg. of ½" (1.3cm) single fold bias tape.

Apron A - one size fits most

45, 60** - 1½ yd. (115, 150cm* - 1.4m)

Hand Towel B - 16" x 24" (41cm x 61cm)

45, 60** - ¾ yd. (115, 150cm* - 0.8m)

Oven Mitt C

45** - ½ yd. (115cm* - 0.5m)

Batting: 45" - ½ yd. (115cm* - 0.5m)

Pot Holder D - 7½" x 7½" (19cm x 19cm)

45** - ¾ yd. (115cm* - 0.3m) each of fabric and batting

Pot Holder E - 9½" diameter (25cm)

45** - ¾ yd. (115cm* - 0.3m) each of fabric and batting

Pan Cover F - Fits 9" x 13" pan (23cm x 33cm)

45** - ¾ yd. (115cm* - 0.5m)

Pan Cover G - Fits 8" x 8" pan (21cm x 21cm)

45** - ½ yd. (115cm* - 0.5m)

Bowl Cover H - Fits 8¾" diameter bowl (23cm)

45** - ½ yd. (115cm* - 0.5m)

Bowl Cover I - Fits 9½" diameter bowl (25cm)

45** - ½ yd. (115cm* - 0.5m)

Bowl Cover J - Fits 11¼" diameter bowl (29cm)

45** - ½ yd. (115cm* - 0.5m)

*with nap **without nap

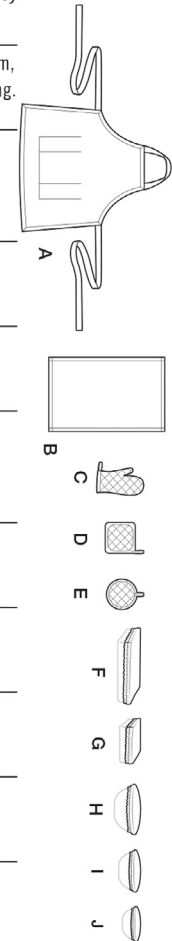

Simplicity® S3058

Thank you for purchasing this Simplicity pattern. We made every effort to provide you with a high quality product.

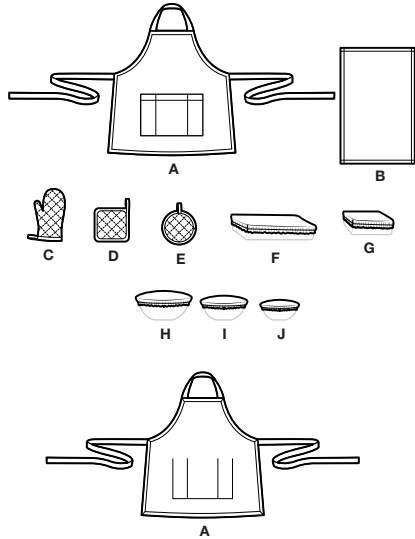

Cutting Layouts

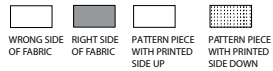

POSITION OF PATTERN PIECES MAY VARY SLIGHTLY ACCORDING TO YOUR PATTERN SIZE

General Directions For Cutting

PRE-SHRINK and iron all fabric.

FOR DOUBLE THICKNESS -Fold fabric with **RIGHT** sides together. Pin pattern to **WRONG** side of fabric.

FOR SINGLE THICKNESS -Pin pattern to **RIGHT** side of fabric.

★ If layout shows a piece extending past fold, cut out all pieces except piece that extends. Open out fabric to single thickness. Cut extending piece on **RIGHT** side of fabric in position shown.

✱ Mark small arrows along both selvages in dicing direction of nap or design. Fold fabric crosswise with **RIGHT** sides together, and cut along fold. Turn one fabric layer around so arrows on both layers go in the same direction. Place **RIGHT** sides together.

APRON A

USE PIECES 1,2,3,4
CUT ONE OF PIECE 3

45" (115CM)
WITH NAP

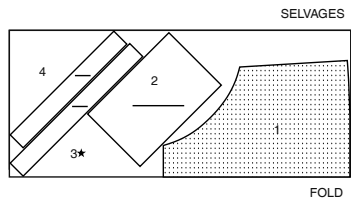

HAND TOWEL B

USE PIECE 5

45" (115CM)
WITH NAP

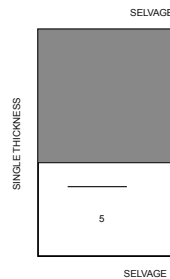

OVEN MITT C

USE PIECE 6

45" (115CM)
WITH NAP

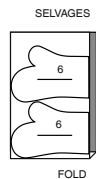

BATTING

USE PIECE 6

45" (115CM)
WITH NAP

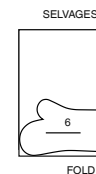

POT HOLDER D

USE PIECE 7

45" (115CM)
WITH NAP

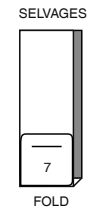

FOR BATTING FOLLOW SAME LAYOUT

POT HOLDER E

USE PIECE 8

45" (115CM)
WITH NAP



FOR BATTING FOLLOW SAME LAYOUT

PAN COVER F

USE PIECE 9

45" (115CM)
WITH NAP



PAN COVER G

USE PIECE 10

45" (115CM)
WITH NAP

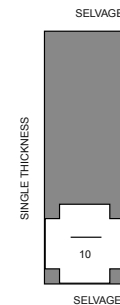

BOWL COVER H

USE PIECE 11

45" (115CM)
WITH NAP

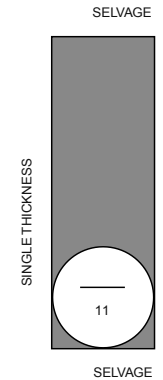

BOWL COVER I

USE PIECE 12

45" (115CM)
WITH NAP

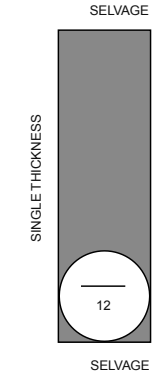

BOWL COVER J

USE PIECE 13

45" (115CM)
WITH NAP

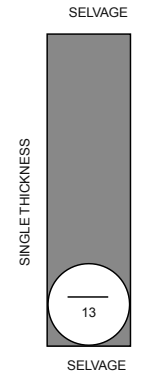

13 PIECES

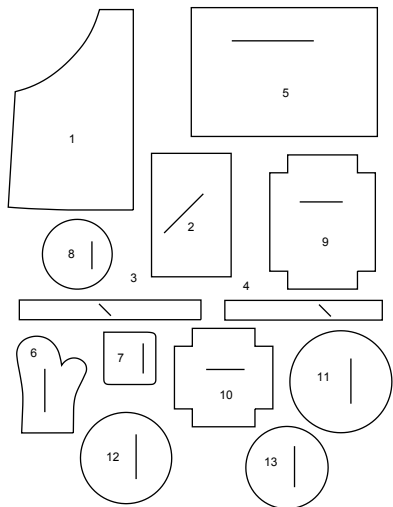

- 1 APRON - A
- 2 POCKET - A
- 3 NECK STRAP - A
- 4 TIE END - A
- 5 TOWEL - B
- 6 MITT - C
- 7 POT HOLDER - D
- 8 POT HOLDER - E
- 9 COVER - F
- 10 COVER - G
- 11 COVER - H
- 12 COVER - I
- 13 COVER - J

SEWING TUTORIALS



Build your skills viewing short, easy-to-follow videos at simplicity.com/sewingtutorials

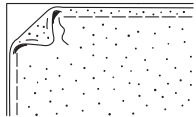

BATTING or INTERLINING

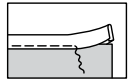

BINDING



INWARD CURVE



OUTWARD CURVE

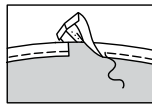

ENDS

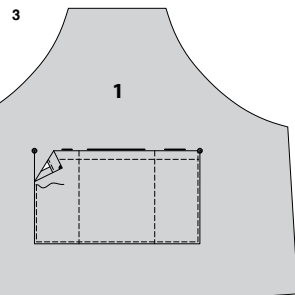
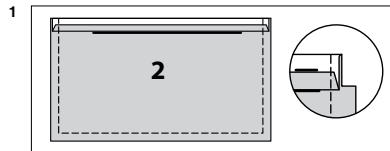

Sewing Directions

FABRIC KEY RIGHT SIDE WRONG SIDE INTERFACING LINING LACING

Sewing methods in **BOLD TYPE** have Sewing Tutorial Video available. Scan **QR CODE** to watch videos:

EDGESTITCH - see **Machine Stitches: "how to edgestitch"** video.

SLIPSTITCH - Slide needle through a folded edge, then pick up a thread of underneath fabric.

PATTERN PIECES WILL BE IDENTIFIED BY NUMBERS THE FIRST TIME THEY ARE USED.
STITCH SEAMS WITH RIGHT SIDES TOGETHER UNLESS OTHERWISE STATED.

NOTE: Under each sub-heading, the first view will be illustrated, unless otherwise illustrated.

BATTING or INTERLINING -Pin padding to **WRONG** side of project section, having raw edges even. Baste padding in place along seam lines.

BINDING -Double fold bias tape comes with one side slightly wider than the other. The wider side is used on the **INSIDE** so that when the tape is stitched in place from the **OUTSIDE**, both edges are caught in the stitching.

To finish edge of your project, slip the edge between the folds of the bias tape placing the raw edge against the center crease and the wider folded edge of the tape on the **WRONG** side of your project. Stitch the tape in place from the **OUTSIDE**, being sure to catch in the folded edge on the **UNDERSIDE**.

Curves:

If tape is applied to a curved surface, first, preshape it with a steam iron.

For an inward curve, stretch the double edges and press.

For an outward curve, stretch the fold edge and press.

ENDS:

Turn tape ends under to finish or enclose in the seam when possible. When tape completely encloses an edge, arrange to have ends meet at a seam; then turn both ends under where they meet and tack together invisibly after stitching on tape.

APRON A

1. Press under 1/2"(1.3cm) on upper edge of **POCKET (2)**. Turn upper edge to **OUTSIDE** along foldline, forming facing. Stitch in a 1/2"(1.3cm) seam on raw edges. Trim seam allowance in the facing area to 1/4"(6mm).

2. Turn corners **RIGHT** side out, turning facing to the **WRONG** side; press, pressing under raw edges along stitching. Stitch facing close to inner edge.

3. On **OUTSIDE**, pin pocket to **APRON (1)** along pocket lines, matching centers and dots. Stitch close to sides and lower edge. Stitch pocket along stitching lines, stitching through all layers.

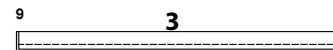
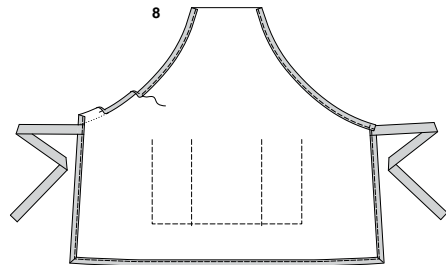
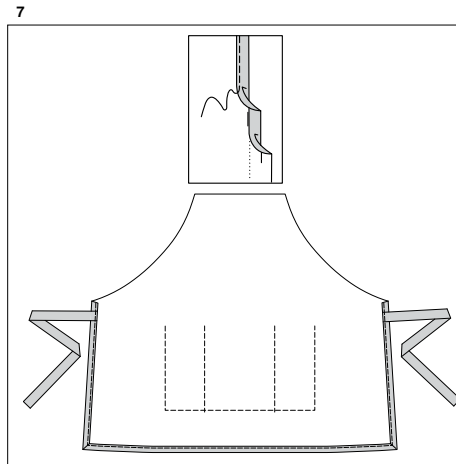
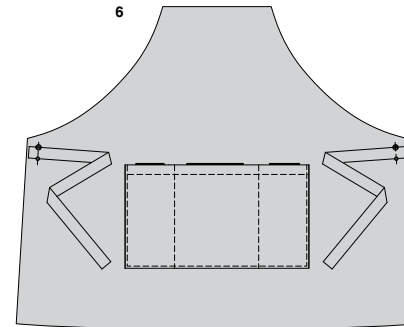
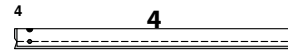

4. With **RIGHT** sides together, fold each **TIE END (4)** in half lengthwise, matching small dots. Stitch in a 3/8"(1cm) seam, leaving end with dots open; trim seams.

5. Turn **RIGHT** side out; press. Baste raw edges.

6. On outside, pin ties to side edges of apron, matching dots, having raw edges even. Stitch along hem allowance.

7. Press up 1"(2.5cm) hem on side edges of apron with a double hem. To make a double hem, turn under 1/2"(1.3cm) on side edges. Turn under 1/2"(1.3cm) again; press. Stitch hem in place close to fold, keeping ends of tie ends free of stitching, folding in fullness at corners. Hem lower edge of apron in the same manner as for side edges.

8. Press up 1"(2.5cm) hem on curved edges of apron with a double hem. To make a double hem, turn under 1/2"(1.3cm) on curved edges. Turn under 1/2"(1.3cm) again; press. Stitch hem in place close to fold, easing in fullness, if necessary, folding in fullness at corners.

9. With **RIGHT** sides together, fold each **NECK STRAP (3)** in half lengthwise. Stitch in a 3/8"(1cm) seam, leaving short ends open; trim seams.



10. Turn RIGHT side out; press. Baste raw edges.

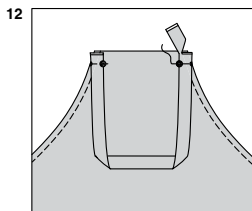
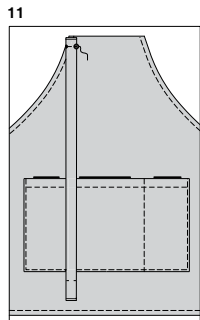

11. On outside, pin end of strap (without extension) to upper edge of apron, matching dots; having raw edges even. Baste.

12. Pin end of strap with extension to upper edge of apron, matching dots. Try on and adjust length of strap if necessary. If desired, cut excess strap even upper edge of apron. Baste.

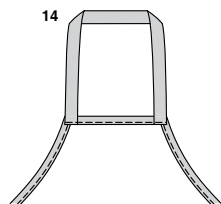
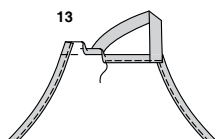

13. Press up 1"(2.5cm) hem on upper edge of apron with a double hem. To make a double hem, turn under 1/2"(1.3cm) on upper edge. Turn under 1/2"(1.3cm) again; press. Stitch hem in place close to fold, keeping ends of strap free of stitching, folding in fullness at corners.

14. Turn strap over hem, as shown; press.

TOWEL B

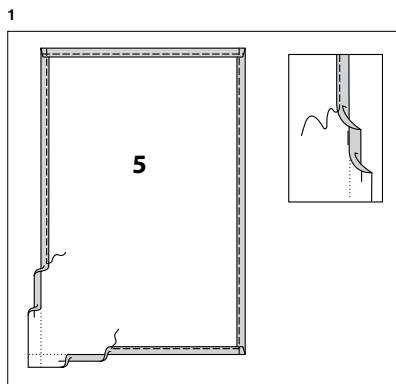

1. Finish long edges of TOWEL (5) with a double hem. To make a double hem, turn under 1/2"(1.3cm) on long edges. Turn under 1/2"(1.3cm) again; press. Stitch hem in place close to fold. Hem upper and lower edges of towel in the same manner as for long edges.

OVEN MITT C

NOTE: You have cut four oven mitt sections of fabric. Two sections will be referred to as mitt lining and used to finish the INSIDE of oven mitt.

1. Pin **BATTING** to wrong side of two MITT (6) sections, having raw edges even. Baste. (This is mitt front.)
2. On OUTSIDE, stitch each mitt front along stitching lines, through all thicknesses.

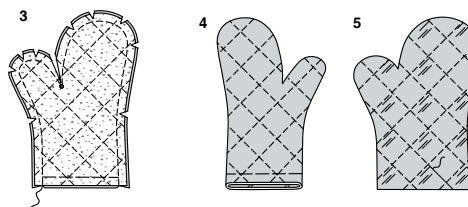

3. With RIGHT sides together, pin mitt front sections, matching dots, having raw edges even. Stitch sides and upper edge, pivoting at dot, leaving lower edge free. Trim seams; clip curves and slash inward corner to dot.

4. Turn mitt RIGHT side out; press.

5. On OUTSIDE, stitch each mitt LINING (6) along stitching lines.

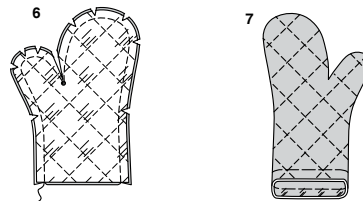

6. With RIGHT sides together, pin lining sections, matching dots, having raw edges even. Stitch sides and upper edge, pivoting at dot, leaving lower edge free. Trim seams; clip curves and slash inward corner to dot.

7. With WRONG sides together, slip lining inside mitt, matching seams, having lower edges are even. Baste lower edge.

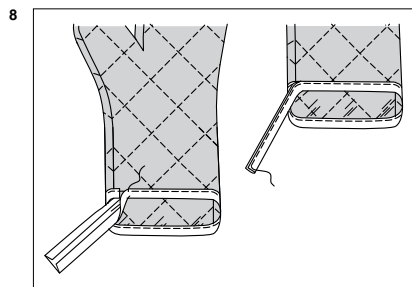

8. Starting at seam on thumb section of mitt, encase lower edge in double fold bias tape, having end extending 5"(12.5cm) beyond thumb seam. Stitch bias tape close to inner edge, continuing to stitch pressed edges of extending bias tape together.

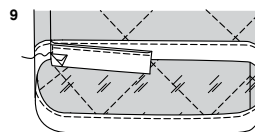

9. Fold end of extending bias tape down, forming loop. Press under end and stitch in place along previous stitching.

POT HOLDER D

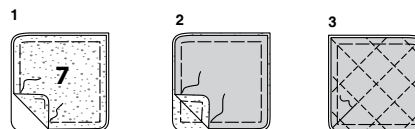

1. Apply **BATTING** to wrong side of each POT HOLDER (7) section, having raw edges even.

2. With batting sides together, pin pot holder sections, having raw edges even; baste.

3. On OUTSIDE, stitch pot holder along stitching lines, through all thicknesses.

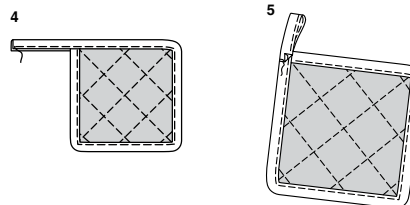

4. Encase outer edges of pot holder in double fold bias tape, easing tape along curves, having end extending 4"(10cm) beyond straight edge of pot holder. Stitch bias tape close to inner edge, continuing to stitch pressed edges of extending bias tape together.

5. Fold end of extending bias tape down, forming loop. Press under end and stitch in place along previous stitching.

POT HOLDER E

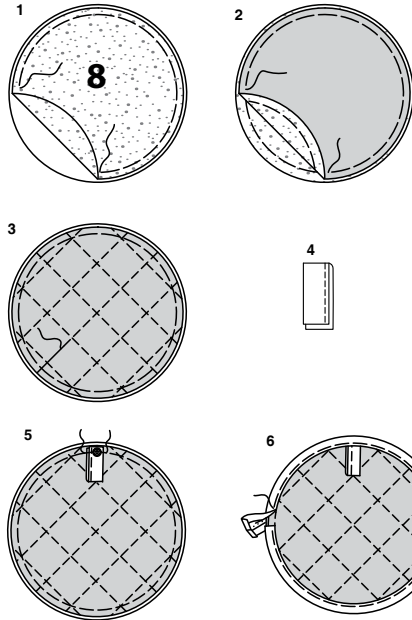

1. Apply **BATTING** to wrong side of each POT HOLDER (8) section, having raw edges even.
2. With batting sides together, pin pot holder sections, having raw edges even; baste.
3. Stitch pot holder along stitching lines, through all thicknesses.
4. To make loop, cut a 4*(10cm) piece of double fold bias tape. Stitch pressed edges of tape together. Fold loop in half, having ends even.
5. Baste loop to pot holder, centering over large dot, having raw edges even.
6. Encase outer edges of pot holder in double fold bias tape, easing tape along curve, turning under one end and lapping over starting point. **EDGESTITCH** inner edge of tape.

PAN COVER F, G

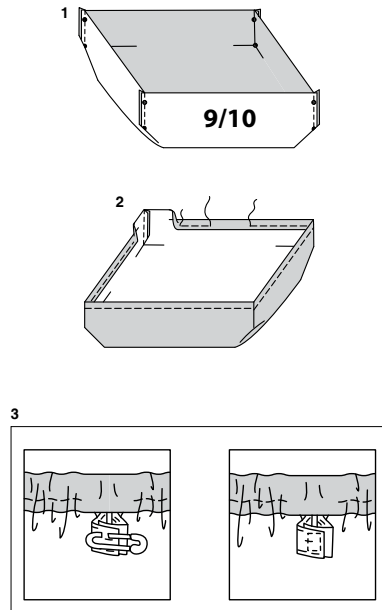

1. To form corners, fold COVER (9) or (10), **RIGHT** sides together, matching dots. Stitch along dart seams.
2. Turn pan cover to inside along foldline, forming casing. Stitch turned edge along stitching line, leaving an opening to insert elastic.
FOR VIEW F: Cut elastic 25-1/2*(65cm) long.
FOR VIEW G: Cut elastic 20-1/2*(52cm) long.
3. Insert elastic through casing, lapping ends 1/4*(6mm). Hold with a safety pin. Try on pan and adjust if necessary. Stitch ends of elastic securely.

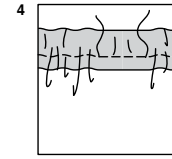

4. Stitch opening in casing, stretching elastic while stitching.



1. Open out one folded edge of bias tape. Press lightly.

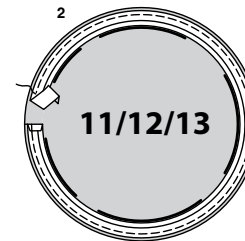

2. Pin this edge to outer edge of COVER (11), (12) or (13), **RIGHT** sides together, having raw edges even, turning under 1/4*(6mm) on ends. Stitch in a 1/4*(6mm) seam. Trim seam to a scant 1/4*(6mm).

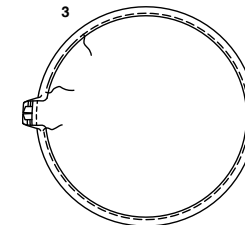

3. Turn bias tape to inside along seam, forming casing. Baste close to inner edge. Stitch close to basted edge, stretching tape to fit.
FOR VIEW H: Cut elastic 21-1/2*(55cm) long.
FOR VIEW I: Cut elastic 19-1/2*(49.5cm) long.
FOR VIEW J: Cut elastic 17-1/2*(44.5cm) long.

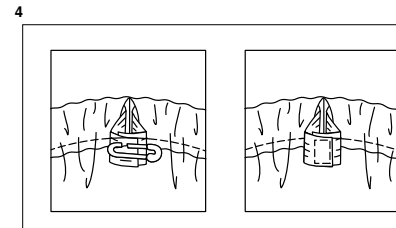

4. Insert elastic through casing, lapping ends 1/4*(6mm). Hold with a safety pin. Stitch ends of elastic securely.

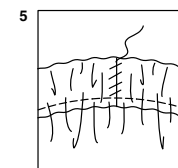

5. **SLIPSTITCH** ends of casing together.



Congrats!

You've completed your sewing adventure

**SHARE
YOUR** LOOK



Post your pattern and tag us
[@simplicity_creative_group](#) and [#simplicitypatterns](#)
for a chance to be featured on our social media.

Look for more PDF patterns at simplicity.com

Have a question or need help with your sewing project call us at
1-888-588-2700



Simplicity ©2024 a division of IG Design Group Americas Inc. • Atlanta, GA 30342 USA www.thedesigngroup.com • All Rights Reserved. www.simplicity.com • Made in the U.S.A. Fabriqué aux États-Unis.

To be used for individual private home use only and not for commercial or manufacturing purposes. • A usage privé seulement et non à des fins commerciales ou de production en série. • Para uso privado solamente, no se puede utilizar con propósitos de comercialización o de producción en serie.