

S3031

# Simplicity<sup>®</sup> COSTUMES



 Designed and printed in USA.

Average

## ADULT COSTUME HATS

**Suggested Fabrics:** A,B,C,D: Brocade, Cotton Types, Dupioni, Jacquard, Linen Types, Satin, Shantung, Taffeta, Velvet. E: Lace, Novelty Mesh, Tulle. **Interfacing:** Felt.

**Notions:** A,B,C,D: ½" (1.3cm) vinyl tape, fabric glue or hot glue gun and glue sticks, assorted charms, flowers, ribbons and embellishments as desired, 15-gauge wire: 2½ yds. (1.9m) for A,C, 1½ yds. (1.4m) for B,D, E: 2½ yds. (2.7m) of 1½" (4cm) single-edge galloon/scalloped lace trim.

### Hat A

45, 60"\* - ¾ yd. (115, 150cm\* - 0.7m)

**Contrast (Brim, Crown):** 45, 60"\* - ¾ yd. (115, 150cm\* - 0.7m)

**Interfacing:** 72" - ¾ yd. (115, 150cm\* - 0.7m)

### Hat B

45, 60"\* - ⅝ yd. (115, 150cm\* - 0.6m)

**Contrast (Brim, Crown):** 45, 60"\* - ⅝ yd. (115, 150cm\* - 0.6m)

**Interfacing:** 72" - ⅝ yd. (115, 150cm\* - 0.6m)

### Hat C

45, 60"\* - ¾ yd. (115, 150cm\* - 0.7m)

**Contrast (Brim, Crown):** 45, 60"\* - ¾ yd. (115, 150cm\* - 0.7m)

**Interfacing:** 72" - ¾ yd. (115, 150cm\* - 0.7m)

### Hat D

45, 60"\* - ⅝ yd. (115, 150cm\* - 0.6m)

**Contrast (Brim, Crown):** 45, 60"\* - ⅝ yd. (115, 150cm\* - 0.6m)

**Interfacing:** 72" - ⅝ yd. (115, 150cm\* - 0.6m)

### Veil E

45, 60"\* - 1 yd. (115, 150cm\* - 0.9m)



A



B



C



D

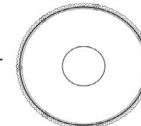

E

\*with nap \*\*without nap

Shop all the pattern brands you love @

**Simplicity<sup>®</sup>.com**

# Simplicity® S3031

Thank you for purchasing this Simplicity pattern.  
We made every effort to provide you with a high quality product.

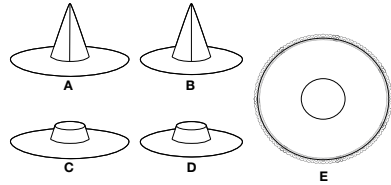
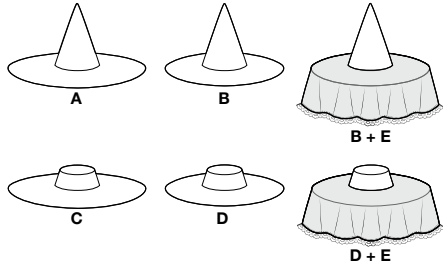

6 PIECES

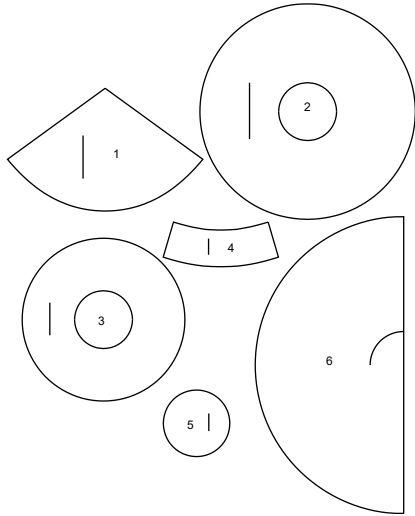

- 1 CROWN - A,B
- 2 BRIM - A,C
- 3 BRIM - B,D
- 4 CROWN - C,D
- 5 TOP - C,D
- 6 VEIL - E

## Cutting Layouts

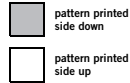

POSITION OF PATTERN PIECES MAY VARY SLIGHTLY ACCORDING TO YOUR PATTERN SIZE

### General Directions For Cutting

**PRE-SHRINK** and iron all fabric.

**FOR DOUBLE THICKNESS** -Fold fabric with **RIGHT** sides together. Pin pattern to **WRONG** side of fabric.

**FOR SINGLE THICKNESS** -Pin pattern to **RIGHT** side of fabric.

★ If layout shows a piece extending past fold, cut out all pieces except piece that extends. Open out fabric to single thickness. Cut extending piece on **RIGHT** side of fabric in position shown.

✳ Mark small arrows along both selvages in dicing direction of nap or design. Fold fabric crosswise with **RIGHT** sides together, and cut along fold. Turn one fabric layer around so arrows on both layers go in the same direction. Place **RIGHT** sides together.

### HAT A

USE PIECES 1 2

45°, 60° (115,150CM) WITH NAP

FOR FELT INTERFACING FOLLOW SAME LAYOUT

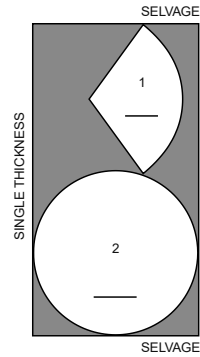

### CONTRAST (BRIM, CROWN)

USE PIECES 1 2

45°, 60°(115,150CM) WITH NAP

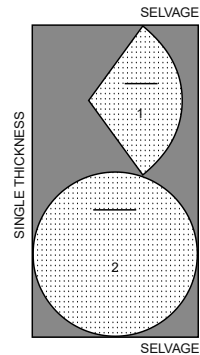

### HAT B

USE PIECES 1 3

45°, 60° (115,150CM) WITH NAP

FOR FELT INTERFACING FOLLOW SAME LAYOUT

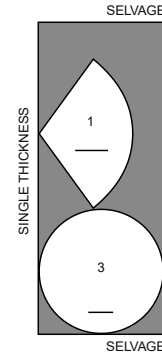

### CONTRAST (BRIM, CROWN)

USE PIECES 1 3

45°, 60° (115,150CM) WITH NAP

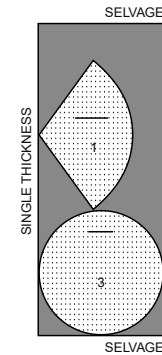

### HAT C

USE PIECES 2 4 5

45°, 60° (115,150CM) WITH NAP

FOR FELT INTERFACING FOLLOW SAME LAYOUT

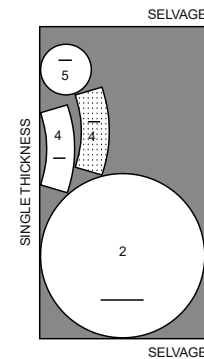

### CONTRAST (BRIM, CROWN)

USE PIECES 2 4 5

45°, 60° (115,150CM) WITH NAP

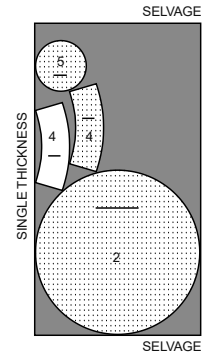

### HAT D

PIECES 3 4 5

45°, 60° (115,150CM) WITH NAP

FOR FELT INTERFACING FOLLOW SAME LAYOUT

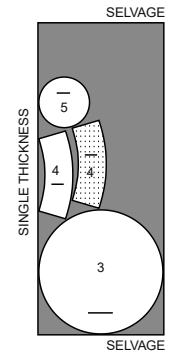

### CONTRAST (BRIM, CROWN, TOP)

USE PIECES 3 4 5

45°, 60° (115,150CM) WITH NAP

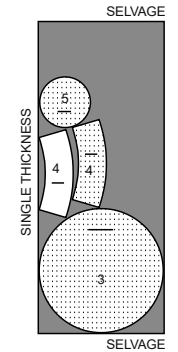

### VEIL E

USE PIECE 6

45°, 60° (115,150CM) WITH NAP

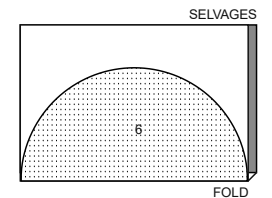

## SEWING TUTORIALS



Build your skills viewing short, easy-to-follow videos at [simplicity.com/sewingtutorials](https://www.simplicity.com/sewingtutorials)

## Sewing Directions

FABRIC KEY



Read **General Directions** on page 1 before you begin.

Sewing methods in **BOLD TYPE** have Sewing Tutorial Video available. Scan QR CODE to watch videos:

**EDGESTITCH** – See Machine Stitches: “how to sew an edgestitch” video.

**SLIPSTITCH** – See Hand Stitching: “how to slip stitch” video.

**TRIM SEAM** – See Seams: “how to trim, clip and layer seams” video.

**UNDERSTITCH** – See Machine Stitches: “how to understitch” video.

**PATTERN PIECES WILL BE IDENTIFIED BY NUMBERS THE FIRST TIME THEY ARE USED.**

**STITCH 1/2" (1.3CM) SEAMS WITH RIGHT SIDES TOGETHER UNLESS OTHERWISE STATED.**

COSTUME HAT A, B, C, D,  
WITH OPTIONAL VEIL E

## PIECE PREPARATION

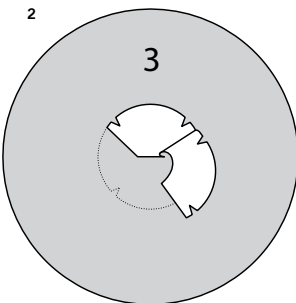
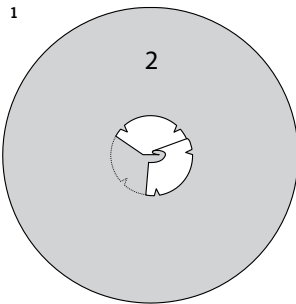

1. **FOR VIEW A, C** – Cut inner circle away from BRIM (2) sections.

2. **FOR VIEW B, D** – Cut inner circle away from BRIM (3) sections.

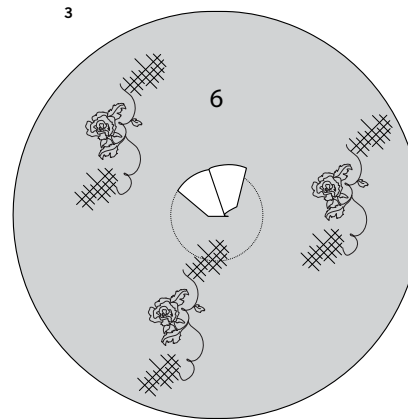

3. **FOR VIEW E** – Cut inner circle away from Veil (6) section.

## INTERFACING

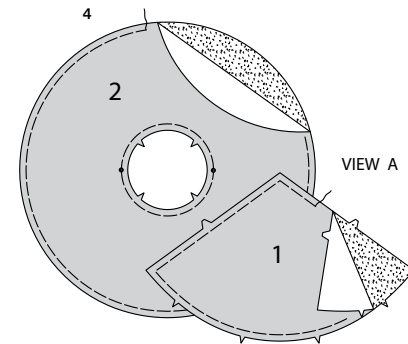

4. **FOR VIEW A** – Pin felt interfacing to **WRONG** side of CROWN (1) and BRIM (2) sections. Baste a scant 1/2" (1.3 cm) from raw edges.

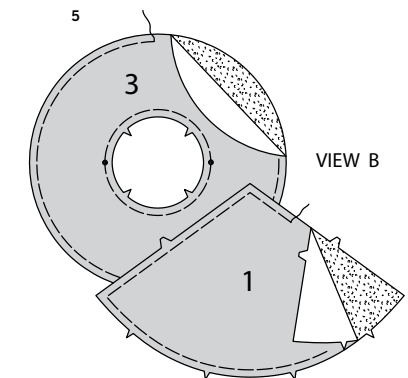

5. **FOR VIEW B** – Pin felt interfacing to **WRONG** side of CROWN (1) and BRIM (3) sections. Baste a scant 1/2" (1.3 cm) from raw edges.

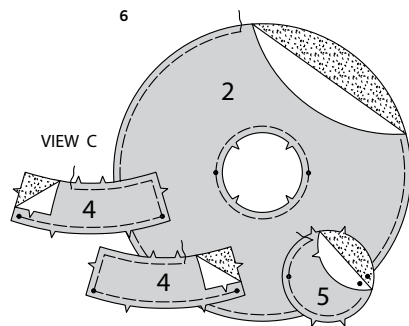

6. **FOR VIEW C** – Pin felt interfacing to **WRONG** side of CROWN (4), TOP (5), and BRIM (2) sections. Baste a scant 1/2" (1.3 cm) from raw edges.

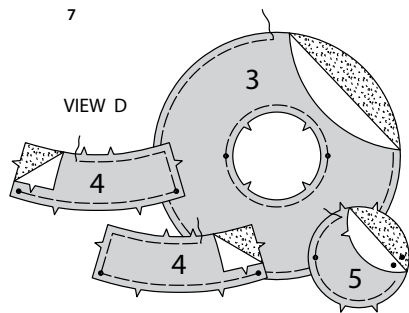

7. **FOR VIEW D** – Pin felt interfacing to **WRONG** side of CROWN (4), TOP (5), and BRIM (3) sections. Baste a scant 1/2" (1.3 cm) from raw edges.

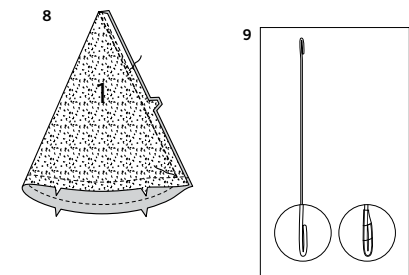

8. Machine-stitch 1/2" (1.3 cm) from curved edge of CROWN (1). Stitch center back edges together from upper edge to lower seamline, back-stitching to reinforce. To form casing for wire, stitch along seam allowance a generous 1/8" (1.3 cm) from seam.

9. Cut a piece of wire 13" (33cm) long. Turn under 3/4" (2cm) on ends and wrap with 1/2" (1.3cm) wide tape to hold in place.

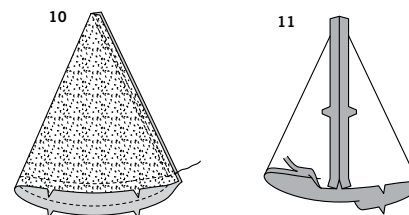

10. Thread wire through casing in crown. Baste along lower seamline.

11. Stitch center back edges of crown contrast lining together from upper edge to lower seamline, back-stitching to reinforce. **TRIM SEAM.** Press seam open. Press under lower edge of crown lining along seamline. Trim to 1/4" (6 mm).

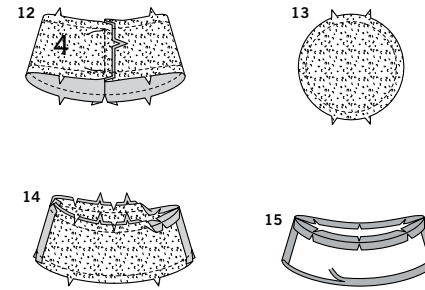

### CROWN C, D

12. Machine-stitch 1/2" (1.3 cm) from curved edges of CROWN (4) sections. Stitch side edges together between upper and lower seamlines, back-stitching to reinforce.

13. Machine-stitch 1/2" (1.3 cm) from raw edge of TOP (5).

14. With **RIGHT** sides together and raw edges even, pin crown to top, matching centers and notches, placing side seams at small dots, clipping to stitching, as necessary. Baste; stitch. Press seam open.

15. Stitch crown and top contrast lining sections together in the same manner. Press under lower edge of crown lining along seamline. Trim to 1/4" (6mm).

### BRIM A, C

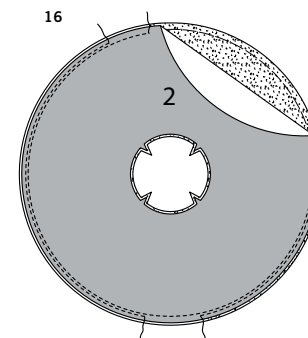

16. With **RIGHT** sides together and raw edges even, pin BRIM (2) to brim contrast lining. Stitch unnotched edge. To form casing for wire, stitch along seam allowance 1/4" (6mm) from seam, leaving an opening to insert wire.

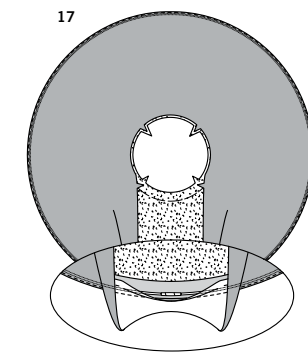

17. **UNDERSTITCH** the lining. Turn brim; press. Cut a piece of wire 70" (178cm) long. Pre-shape wire to match outer edge of brim. Open out the lining. On **INSIDE**, thread wire through opening in casing. Lap ends and wrap with 1/2" (1.3cm) wide tape to hold in place.

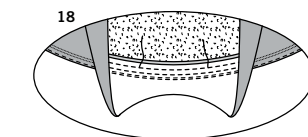

18. Stitch opening closed.

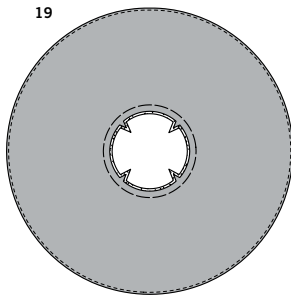

19. Press lining back in place. Baste raw edges together.

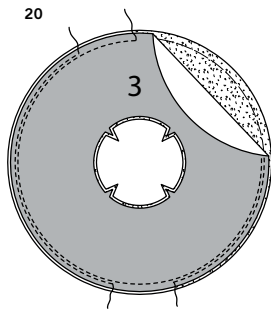

### BRIM B, D

20. With RIGHT sides together and raw edges even, pin BRIM (3) to brim contrast lining. Stitch unnotched edge. To form casing for wire, stitch along seam allowance 1/4" (6mm) from seam, leaving an opening to insert wire.

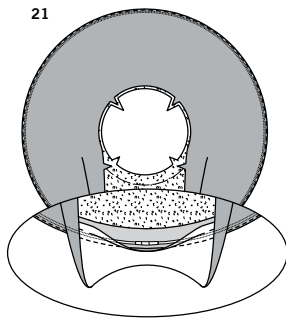

21. **UNDERSTITCH** the lining. Turn brim; press. Cut a piece of wire 51-1/2" (131.3cm) long. Pre-shape wire to match outer edge of brim. Open out the lining. On INSIDE, thread wire through opening in casing. Lap ends and wrap with 1/2" (1.3cm) wide tape to hold in place.

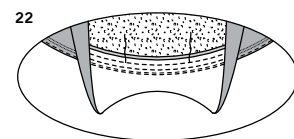

22. Stitch opening closed.

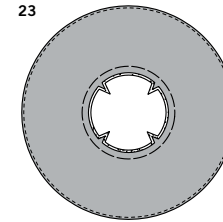

23. Press lining back in place. Baste raw edges together.

### CONTINUE AS FOLLOWS FOR ALL VIEWS

**NOTE:** View D will be shown in the following illustrations.

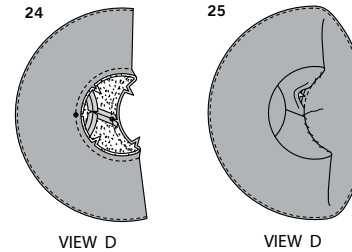

24. With RIGHT sides together and raw edges even, pin brim to crown, matching centers and notches, and placing small dots at side seams for View C and D. Clip seam allowance to stitching as needed. Stitch. Press seam toward crown.

25. Turn hat. With wrong sides together, pin pressed edge of crown lining to crown over seam, matching centers. **SLIPSTITCH** in place.

As you prefer or as shown on envelope, embellish hat using assorted charms, flowers, and ribbons, hand-sewing or tacking in place, or applying with fabric glue or hot glue.

### VEIL E

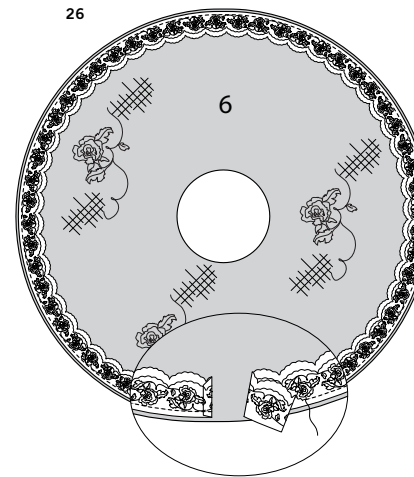

26. With RIGHT sides together and edges even, pin straight edge of scalloped lace to outer edge of VEIL (6), turning under and lapping ends at center back. Stitch 1/8" (6mm) from straight edge of lace.

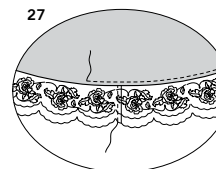

27. Press out lace, pressing seam toward veil. **EDGESTITCH** close to lapped end, as shown. Trim seam. If you prefer, **EDGESTITCH** veil close to seam. Place **WRONG** side of veil to **RIGHT** side of brim, as shown on front of envelope.



# Congrats!

You've completed your sewing adventure

---

**SHARE  
YOUR** LOOK



Post your pattern and tag us  
[@simplicity\\_creative\\_group](#) and [#simplicitypatterns](#)  
for a chance to be featured on our social media.

Look for more PDF patterns at [simplicity.com](http://simplicity.com)

Have a question or need help with your sewing project call us at  
1-888-588-2700



Simplicity ©2024 a division of IG Design Group Americas Inc. • Atlanta, GA 30342 USA [www.thedesigngroup.com](http://www.thedesigngroup.com) • All Rights Reserved. [www.simplicity.com](http://www.simplicity.com) • Made in the U.S.A. Fabriqué aux États-Unis.

To be used for individual private home use only and not for commercial or manufacturing purposes. • A usage privé seulement et non à des fins commerciales ou de production en série. • Para uso privado solamente, no se puede utilizar con propósitos de comercialización o de producción en serie.