

McCall's

M8521



Designed and printed in USA

Shop all the pattern brands you love @

Simplicity.com

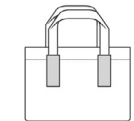
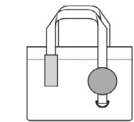
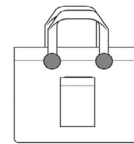
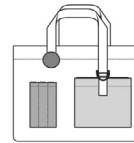
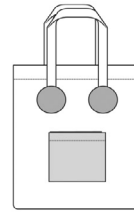
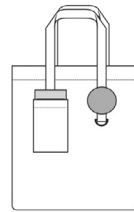

C

TOTE BAGS

Suggested Fabrics: Canvas, Chintz, Cotton Duck, Denim, Twill. **A,B,C Contrasts** in Faux Leather, Vinyl. **Lining:** Cotton Types. **Interfacing:** Fusible Fleece.

Notions: A,B,C 1" (2.5cm) nylon webbing: 2½ yds. (1.9m) for A, 1½ yds. (1.4m) for B,C, 1" (2.5cm) D-Ring(s): one for A,C, two for B.

Tote A

45, 60** - ⅝ yd.

A Contrast 1 (Rectangle Patch, Back Pocket) - 7" x 10" remnant

A Contrast 2 (Circle Patch) - 4" x 10" remnant

Lining: 45*** - ⅝ yd.

Interfacing: 45" - ¾ yd.

Tote B

45, 60** - ½ yd.

B Contrast 1 (Front Pocket) - 7" x 7" remnant

B Contrast 2 (Pencil Pocket) - 4" x 7" remnant

B Contrast 3 (Patch) - 3" x 19" remnant

Lining: 45*** - ½ yd.

Interfacing: 45" - ½ yd.

Tote C

45, 60** - ½ yd.

C Contrast 1 (Circle Patch) - 4" x 4" remnant

C Contrast 2 (Rectangle Patch) - 4" x 10" remnant

Lining: 45*** - ½ yd.

Interfacing: 45" - ½ yd.

SACS FOURRE-TOUT

Tissus Conseillés: Canevas, Chintz, Coutil de coton, Denim, Twill. **A,B,C Contrastes** en Simili cuir, Vinylé.

Doubleure: Types coton. **Entoilage:** Molleton thermocollant.

Mercerie: A,B,C: Sangle en nylon de 2.5cm: 1.9m pour A, 1.4m pour B,C, anneau(x) D de 2.5cm: 1 pour A,C, 2 pour B.

Tote A

115, 150cm* - 0.6m

A Contraste 1 (Patch rectangulaire, Poche dos) - Morceau de tissu contrastant de 18cm x 25cm

A Contraste 2 (Patch circulaire) - Morceau de tissu contrastant de 10cm x 25cm

Doubleure: 115cm** - 0.6m

Entoilage: 115cm - 0.7m

Tote B

115, 150cm* - 0.5m

B Contraste 1 (Poche devant) - Morceau de tissu contrastant de 18cm x 18cm

B Contraste 2 (Poche crayon) - Morceau de tissu contrastant de 10cm x 18cm

B Contraste 3 (Patch) - Morceau de tissu contrastant de 8cm x 48cm

Doubleure: 115cm** - 0.5m

Entoilage: 115cm - 0.5m

Tote C

115, 150cm* - 0.5m

C Contraste 1 (Patch circulaire) - Morceau de tissu contrastant de 10cm x 10cm

C Contraste 2 (Patch rectangulaire) - Morceau de tissu contrastant de 4cm x 25cm

Doubleure: 115cm** - 0.5m

Entoilage: 115cm - 0.5m

*with nap **without nap

avec sens *sans sens

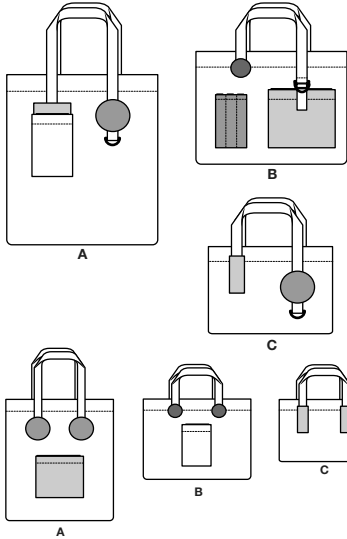

12 PATTERN PIECES

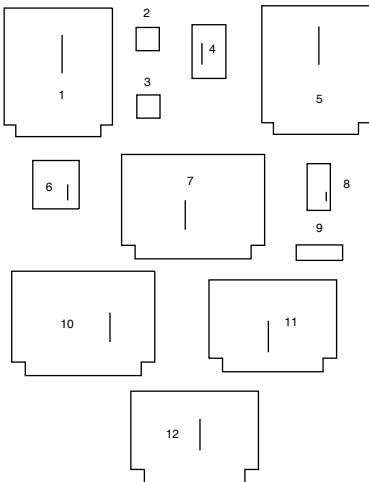

- 1 FRONT - A
- 2 RECTANGLE PATCH - A,C
- 3 CIRCLE PATCH - A,C
- 4 POCKET - A,B
- 5 BACK - A
- 6 BACK POCKET- A/ FRONT POCKET- B
- 7 FRONT - B
- 8 PENCIL POCKET - B
- 9 PATCH - B
- 10 BACK - B
- 11 FRONT - C
- 12 BACK - C

PATTERN MARKINGS

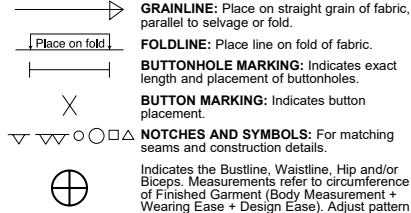

GRAINLINE: Place on straight grain of fabric, parallel to selvage or fold.
FOLDLINE: Place line on fold of fabric.
BUTTONHOLE MARKING: Indicates exact length and placement of buttonholes.
BUTTON MARKING: Indicates button placement.
NOTCHES AND SYMBOLS: For matching seams and construction details.
 Indicates the Bustline, Waistline, Hip and/or Biceps. Measurements refer to circumference of Finished Garment (Body Measurement + Wearing Ease + Design Ease). Adjust pattern if necessary. The measurement excludes pleats, tucks, darts and seam allowances.
SEAM ALLOWANCE: 5/8" (1.5cm) included unless otherwise indicated, but not printed on tissue.

ADJUST IF NECESSARY

Lengthen or Shorten at adjustment lines (==) or where indicated on pattern. If substantial length is added, you may need to purchase additional fabric.
TO SHORTEN: Crease along adjustment line. Make a fold half the amount needed. Tape in place.
TO LENGTHEN: Slash between adjustment lines. Spread amount as needed, keeping edges parallel. Tape over paper.
 When Alteration lines are not on tissue, lengthen or shorten at lower edge.

CUTTING AND MARKING

SHRINK FABRIC if not labeled pre-shrunk. Press.

CIRCLE LAYOUT for View, Size, Fabric Width.

Use **WITH NAP** layout for fabrics with one-way designs, nap, pile or surface shading. Because most knits have surface shading, a with nap layout is used.

For **DOUBLE THICKNESS (WITH FOLD)** - fold fabric with right sides together.

*** DOUBLE THICKNESS (WITHOUT FOLD)** - For fabrics with nap, fold fabric crosswise, right sides together. Mark as shown. Cut along crosswise fold of fabric (A). Turn upper layer 180° so arrows go in same direction and place over lower layer, right sides together (B).

For **SINGLE THICKNESS** - place fabric right side up. (For Fur Pile fabrics, place pile side down.)

★ Cut other pieces first, allowing enough fabric to cut this piece. Open fabric. For "Cut 1" pieces, cut piece once on single layer of fabric with piece face up on right side of fabric.

Pattern may have cutting lines for several sizes. Select the proper cutting line or pattern pieces for your size.

Before **CUTTING** place all pieces on fabric according to layout. Pin. (**Layouts show approximate position of pattern pieces; position may vary according to your pattern size.**) Cut **ACCURATELY**, cutting notches outward.

Before removing pattern, **TRANSFER MARKINGS** and lines of construction to Wrong Side of fabric, using the Pin and Chalk Pencil method or Tracing Paper and Dressmaker Wheel. Markings needed on right side of fabric should be thread traced.

NOTE: Broken-line boxes (a! b! c!) in layouts represent pieces cut by measurements provided.

CUTTING LAYOUTS

RIGHT SIDE OF PATTERN	WRONG SIDE OF PATTERN	RIGHT SIDE OF FABRIC	WRONG SIDE OF FABRIC
-----------------------	-----------------------	----------------------	----------------------

CONTRAST A, B, C

NOTE: FOR LEATHER-LIKE FABRIC, ALTER TISSUE PATTERN BEFORE CUTTING.

PLACE PINS WITHIN SEAM ALLOWANCE OR USE MASKING TAPE.
DO NOT USE A TRACING WHEEL TO TRANSFER MARKING

INTERFACING A

USE PIECES: 1 2 3 5

45" (115 CM) WITH NAP ALL SIZES

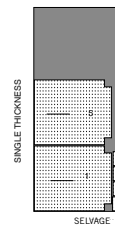

LINING B

USE PIECES: 7 10

45" (115 CM) WITH NAP ALL SIZES



LINING C

USE PIECES: 11 12

45" (115 CM) WITH NAP ALL SIZES

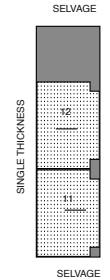

NOTE: FOR INTERFACING FOLLOW SAME LAYOUT

TOTE A

USE PIECES: 1 4 5

45" (115 CM) WITH NAP ALL SIZES



TOTE B

USE PIECES: 4 7 10

45" (115 CM) WITH NAP ALL SIZES

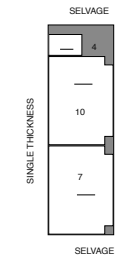

TOTE C

USE PIECES: 11 12

45" (115 CM) WITH NAP ALL SIZES

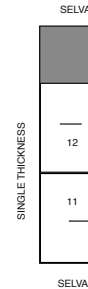

A CONTRAST 1 (RECTANGLE PATCH BACK POCKET)

NOTE: CUT ONE EACH OF PIECE 2 6 FROM REMNANTS

A CONTRAST 2 (CIRCLE PATCH)

NOTE: CUT THREE OF PIECE 3 FROM REMNANTS

B CONTRAST 1 (FRONT POCKET)

NOTE: CUT ONE OF PIECE 6 FROM REMNANTS

B CONTRAST 2 (PENCIL POCKET)

NOTE: CUT ONE OF PIECE 8 FROM REMNANT

B CONTRAST 3 (PATCH)

NOTE: CUT ONE OF PIECE 9 FROM REMNANT

C CONTRAST 1 (CIRCLE PATCH)

NOTE: CUT ONE OF PIECE 3 FROM REMNANTS

C CONTRAST 2 (RECTANGLE PATCH)

NOTE: CUT THREE OF PIECE 2 FROM REMNANTS

INTERFACING B

USE PIECES: 2 3 11 12

45" (115 CM) WITH NAP ALL SIZES

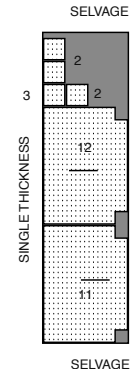

SEWING INFORMATION
FABRIC KEY

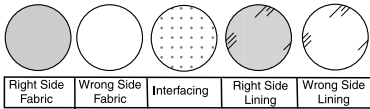

SEAM ALLOWANCES

Use 1/4" (6mm) seam allowances unless otherwise indicated.

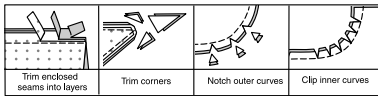

PIN AND FIT

Pin or baste seams, RIGHT SIDE TOGETHER, matching notches. Fit garment before stitching major seams.

PRESS

Press seam allowances flat; then open unless otherwise stated. Clip where necessary so they lie flat.

GLOSSARY

Read General Directions on page 1 before you begin.

EDGE STITCH – see *Machine Stitches: "how to sew an edgestitch"* video.

SLIPSTITCH – see *Hand Stitching: "how to slip stitch"* video.

TOPSTITCH – see *Machine Stitches: "how to topstitch"* video.

PATTERN PIECES WILL BE IDENTIFIED BY NUMBERS THE FIRST TIME THEY ARE USED.

STITCH 1/2" (1.3CM) SEAMS WITH RIGHT SIDES TOGETHER UNLESS OTHERWISE STATED.

SEWING TUTORIALS



Build your skills viewing short, easy-to-follow videos at simplicity.com/sewingtutorials

TOTE A, B, C

NOTE: Since pinholes will remain in faux leather or vinyl fabrics, use basting tape, binder, or seam clips to hold in pieces in place before stitching.

INTERFACING

1. FOR VIEW A – Pin fusible fleece interfacing to WRONG side of FRONT (1) and BACK (5). Fuse interfacing in place following manufacturer's directions.

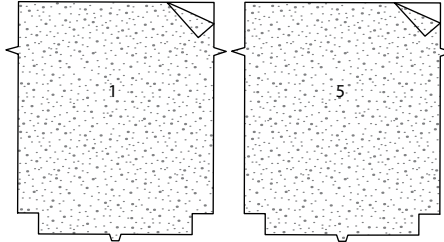

2. FOR VIEW B – Pin fusible fleece interfacing to WRONG side of FRONT (7) and BACK (10). Fuse interfacing in place following manufacturer's directions.

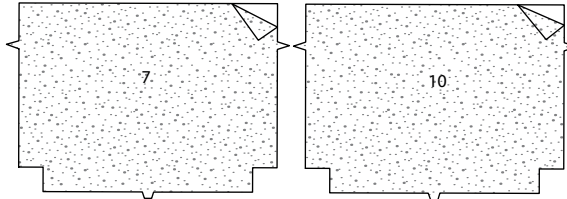

3. FOR VIEW C – Pin fusible fleece interfacing to WRONG side of FRONT (11) and BACK (12). Fuse interfacing in place following manufacturer's directions.

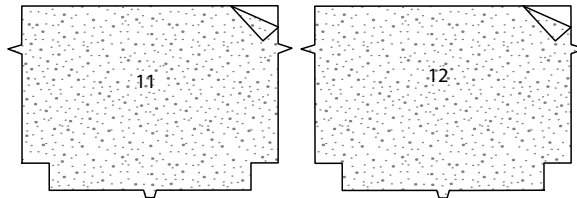

4. FOR VIEW A, C – Apply fusible fleece interfacing to WRONG side of RECTANGLE PATCH (2) and CIRCLE PATCH (3) contrast sections. Fuse interfacing in place following manufacturer's directions. Cut tissue block along outer solid line. Clip or tape pattern to RIGHT side of prepared contrast section. Cut out each shape.

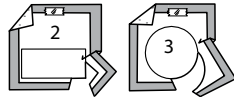

5. FOR VIEW B – Apply fusible fleece interfacing to WRONG side of PATCH (9) contrast section. Fuse interfacing in place following manufacturer's directions. Cut tissue block along outer solid line. Clip or tape pattern to RIGHT side of prepared contrast section. Cut out each shape.

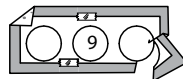

TOTE FRONT A

6. To make front handle, cut a piece of webbing 38" (97cm) long. On OUTSIDE, pin one end of handle to FRONT (1) lapping lower placement line of rectangle 5/8" (1.5cm). Stitch across end.

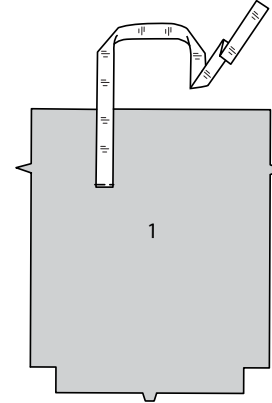

7. Thread remaining end of webbing through a D-ring. Fold under end 3" (7.5cm). On OUTSIDE, pin webbing to front with fold lapping lower placement line of circle a scant 1-1/4" (3.2cm). Stitch across raw end through all thicknesses.

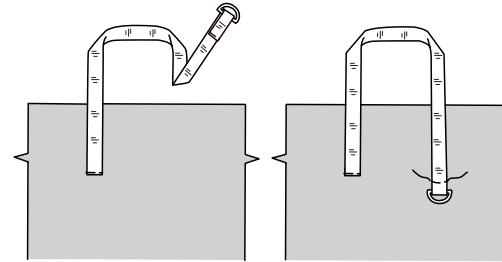

8. Tape RECTANGLE PATCH (2) and CIRCLE PATCH (3) to front between placement lines. **EDGE STITCH** in place.

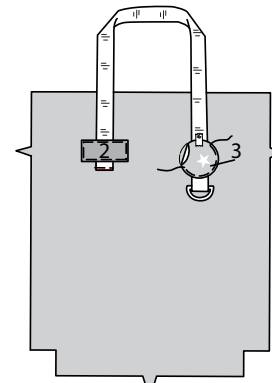

9. Press under 1/4" (6mm) on upper edge of POCKET (4). Turn upper edge to OUTSIDE along fold line, forming facing. Stitch along seam line on raw edges. Trim seam allowance in the facing area to 1/4" (6mm).

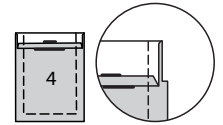

10. Turn corners RIGHT side out, turning facing to the WRONG side, press, pressing under raw edges along stitching. Stitch facing close to inner edge.

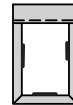

11. On OUTSIDE, pin pocket to front along placement line. Stitch close to side and lower edges.

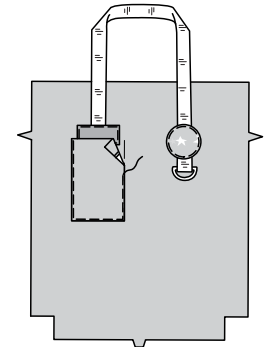

TOTE BACK A

12. To make back handle, cut a piece of webbing 33" (84cm) long. On OUTSIDE, pin ends of handle to BACK (5) along placement lines. Stitch across end.

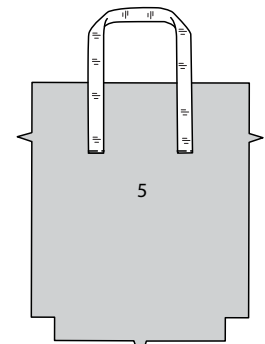

13. Tape circle patches to back between placement lines. **EDGESTITCH** in place.

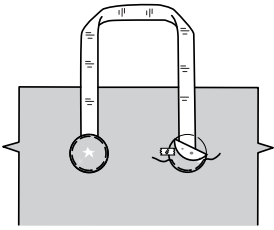

14. Press upper edge of **BACK POCKET** (6) to **INSIDE** along foldline. **EDGESTITCH** inner edge. On **OUTSIDE**, tape pocket to back along placement line. **EDGESTITCH** in place along side and lower edges.

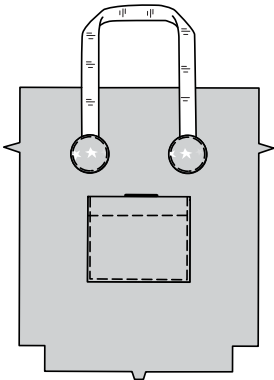
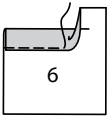

TOTE FRONT B

15. To make front handle, cut a piece of webbing 23" (97cm) long. On **OUTSIDE**, pin one end of handle to **FRONT** (7) lapping placement line of circle. Stitch across end over stitching lines.

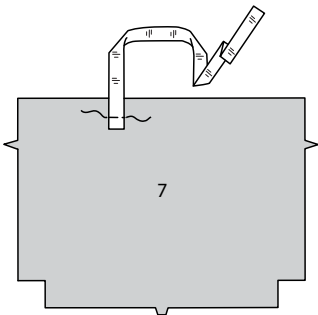

16. Tape **CIRCLE PATCH** (9) to front between placement lines. **EDGESTITCH** in place.

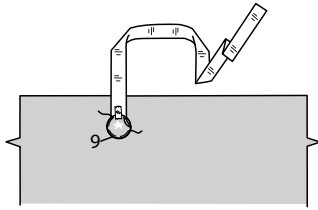

17. Thread remaining end of webbing through two D-rings. Fold under end 3-1/2" (9cm). On **OUTSIDE**, pin webbing to front with fold lapping lower placement line 3/4" (2cm). Stitch across stitching and placement lines through all thicknesses. **EDGESTITCH** handle between placement lines.

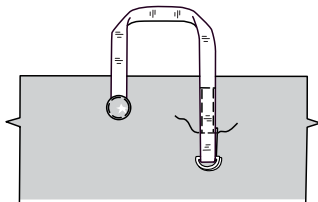
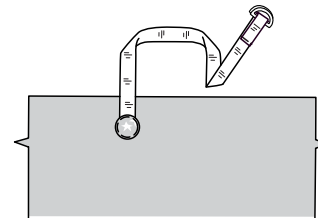

18. Cut a piece of webbing 7-1/2" (19cm) long. Press under 1/2" (1.3cm) on one end. Turn under raw edge to meet crease. Stitch across inner pressed edge.

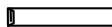

19. Press upper edge of **FRONT POCKET** (6) to **INSIDE** along foldline. **EDGESTITCH** inner edge. Tape raw edge of webbing to **INSIDE** of pocket between placement lines. Stitch in place over stitching lines.

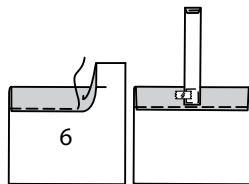

20. On **OUTSIDE**, tape pocket to front along placement line. **EDGESTITCH** in place along side and lower edges. **TOPSTITCH** pocket 1/8" (6mm) from previous stitching.

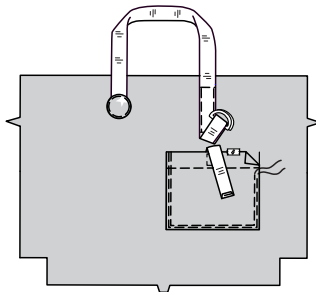

21. Press upper edge of **PENCIL POCKET** (8) to **INSIDE** along foldline. **EDGESTITCH** inner edge.



22. On **OUTSIDE**, tape pocket to front along placement line. **EDGESTITCH** in place along side and lower edges. **TOPSTITCH** pocket 1/8" (6mm) from previous stitching. Stitch along remaining stitching lines through all thicknesses.

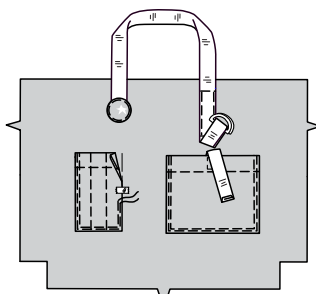

TOTE BACK B

23. To make back handle, cut a piece of webbing 18" (46cm) long. On **OUTSIDE**, pin ends of handle to **BACK** (10) along placement lines. Stitch across ends along placement lines.

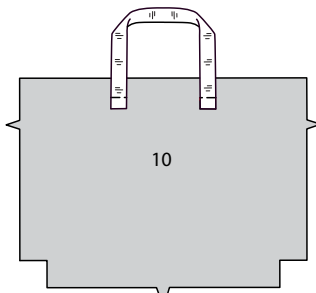

24. Tape remaining circle patches to back between placement lines. **EDGESTITCH** in place.

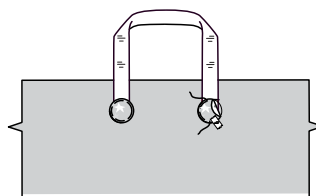

25. Press under 1/4" (6mm) on upper edge of **POCKET** (4). Turn upper edge to **OUTSIDE** along fold line, forming facing. Stitch along seam line on raw edges. Trim seam allowance in the facing area to 1/4" (6mm).

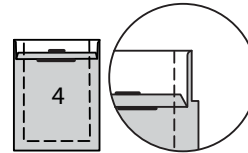

26. Turn corners **RIGHT** side out, turning facing to the **WRONG** side; press, pressing under raw edges along stitching. Stitch facing close to inner edge.

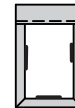

27. On **OUTSIDE**, pin pocket to back along placement line. Stitch pocket close to side and lower edges, and 1/8" (6mm) from previous stitching.

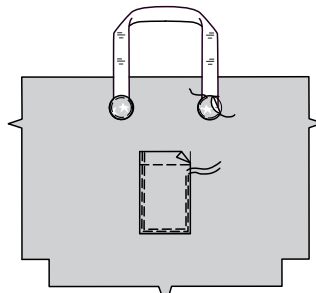

TOTE FRONT C

28. To make front handle, cut a piece of webbing 26-1/2" (67.3cm) long. On **OUTSIDE**, pin one end of handle to **FRONT** (11) along placement lines. Stitch across ends along placement lines.

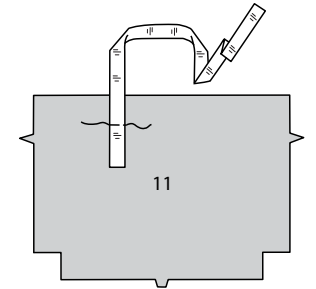

29. Tape **RECTANGLE PATCH** (2) over end of webbing between the placement lines. **EDGESTITCH** close to inner edges of patch.

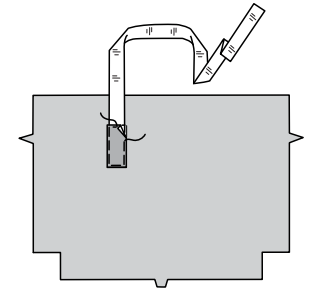

30. Thread remaining end of webbing through a D-ring. Fold under end 2-1/2" (6.3cm). On **OUTSIDE**, pin webbing to front with fold lapping lower placement line of circle a generous 1" (2.5cm). Stitch across stitching and placement lines through all thicknesses.

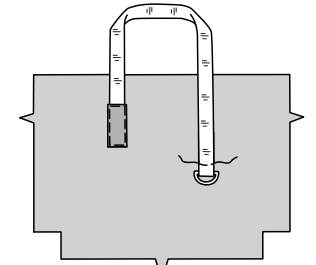
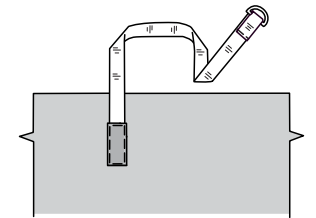

31. Tape CIRCLE PATCH (3) to front between placement lines. **EDGESTITCH** in place.

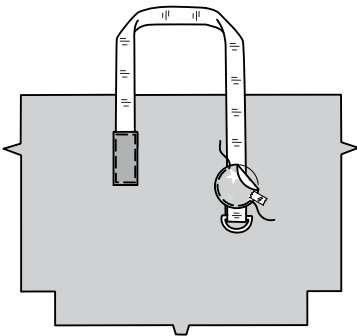

TOTE BACK C

32. To make back handle, cut a piece of webbing 22-1/2" (57.3cm) long. On OUTSIDE, pin ends of handle to BACK (12) along placement lines. Stitch across ends along placement lines.

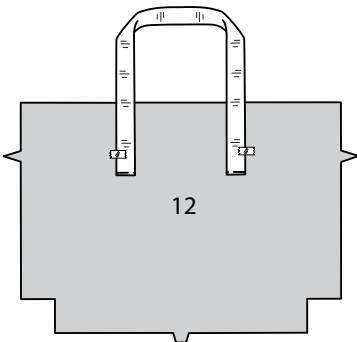

33. Tape remaining rectangle patches over each end of webbing between the placement lines. **EDGESTITCH** close to inner edges of patches.

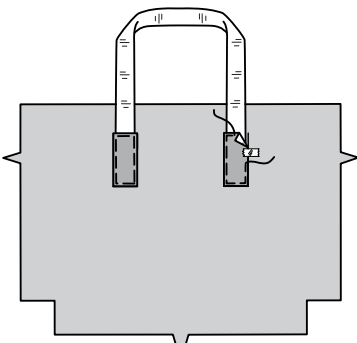

CONTINUE AS FOLLOWS FOR ALL VIEWS

34. With RIGHT sides together, stitch front to back along side and lower edges.

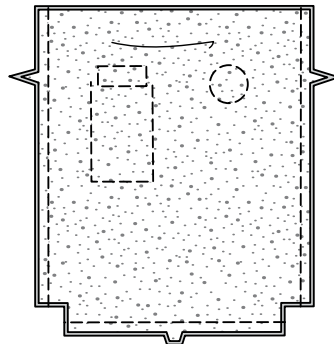

35. To make dart seams at corners, on INSIDE, bring broken lines together, matching small dots and seams. Stitch along broken line between outer small dots.

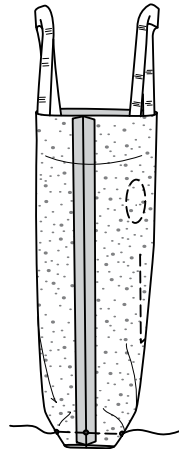

36. Turn bag RIGHT side out; press.

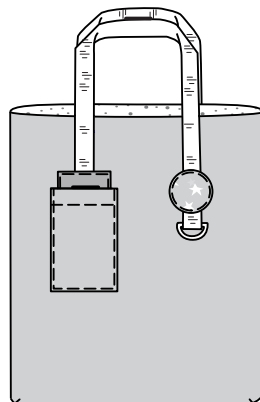

37. Make tote lining in the same manner as tote, leaving an opening in one side edge for turning.

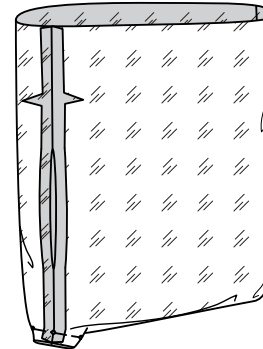

38. With RIGHT sides together and raw edges even, pin lining to tote. Stitch along upper edge. **TRIM SEAM.**

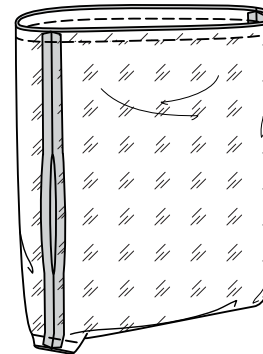

39. Turn lining to INSIDE; press. **SLIPSTITCH** opening closed.

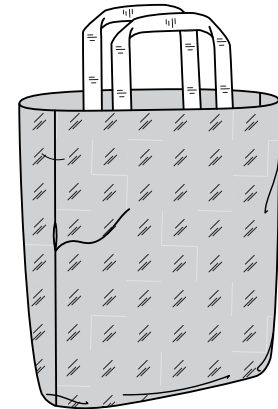

40. FOR VIEWS A, C - On OUTSIDE, **TOPSTITCH** 1-1/4" (3.2cm) from upper edge of tote, breaking stitching at straps.

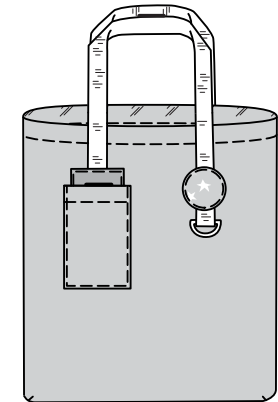

41. FOR VIEW B - On OUTSIDE, **TOPSTITCH** 1-1/4" (3.2cm) from upper edge of tote, breaking stitching at circle patches.

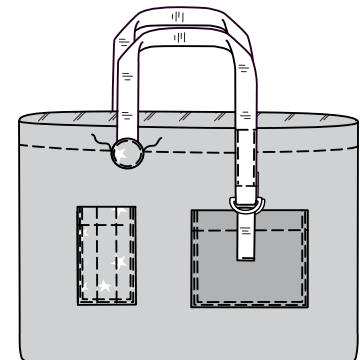



Congrats!

You've completed your sewing adventure

**SHARE
YOUR** LOOK



Post your pattern and tag us
[@simplicity_creative_group](#) and [#simplicitypatterns](#)
for a chance to be featured on our social media.

Look for more PDF patterns at [simplicity.com](https://www.simplicity.com)

Have a question or need help with your sewing project call us at
1-800-782-0323

McCall's
by **design**_{group}

McCall's ©2024 a division of IG Design Group Americas Inc. • Atlanta, GA 30342 USA www.thedesigngroup.com • All Rights Reserved. www.mccall.com • Made in the U.S.A. Fabriqué aux États-Unis.
To be used for individual private home use only and not for commercial or manufacturing purposes. • A usage privé seulement et non à des fins commerciales ou de production en série. • Para uso privado solamente, no se puede utilizar con propósitos de comercialización o de producción en serie.