

# McCall's<sup>®</sup> by design<sub>group</sub> M8300



>> GARDEN ITEMS  
SKILL LEVEL: EASY



PDF PATTERNS

## FRONT

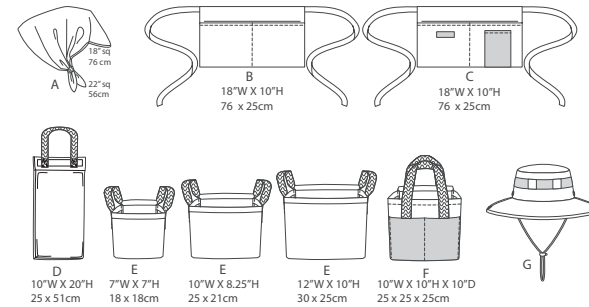

## BACK

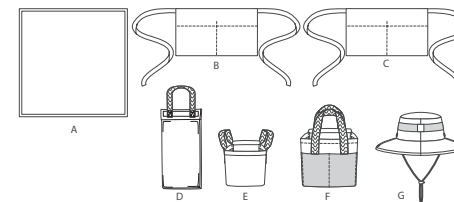

Your printed tile pieces should be assembled before you move on to this step!

### PIECES (18)

- 1 Kerchief A
- 2 Apron B, C
- 3 Tie End B, C
- 4 Tab C
- 5 Pocket C
- 6 Cover D
- 7 Pad D
- 8 Large Planting Bag E
- 9 Medium Planting Bag E
- 10 Small Planting Bag E
- 11 Bag F
- 12 Pocket F
- 13 Top G
- 14 Upper Crown G
- 15 Middle Crown G
- 16 Tab G
- 17 Lower Crown G
- 18 Brim G

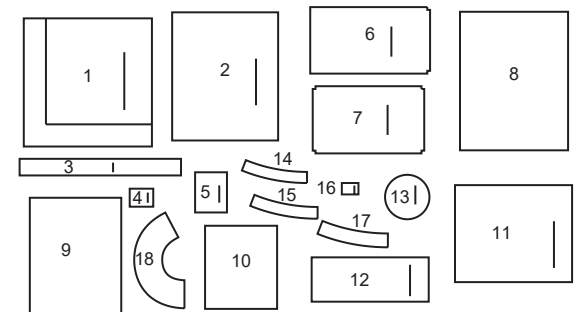

## YARDAGE CHART

**THINGS YOU NEED:**

**D:** 1½ yds. (1.1m) of 1" (2.5cm) wide webbing (straps), ¾ yd. (0.7m) of 1" (2.5cm) wide hook and loop tape, 10" x 18" (25.5cm x 45.5cm) piece of 1" (2.5cm) thick foam. **E,F:** 2" (5cm) wide webbing: 1¼ yds. (1.2m) for **Small Bag E**, 1¾ yds. (1.3m) for **Medium Bag E**, 1½ yds. (1.4m) for **Large Bag E**; 1¼ yds. (1.2m) for **Garden Tote F**. **G:** 1 yd. (1.0m) of ½" (1.3cm) cord, cord stopper, two magnetic snaps.

**SUGGESTED FABRICS:**

**A,B,C, Contrast C:** Cotton/ Cotton Blends. **D,F,G, Also B,C:** Home Dec Fabric, Canvas, Twill, Denim.  
**Contrast D:** Vinyl. **E:** One pkg. of 3' x 50' (91.5cm x 1524cm) Landscape Fabric, Heavy Duty UV Resistant Thread. **Contrast G:** Sport Mesh. **Interfacing G,F:** Heavy Craft Weight or Buckram.

**KERCHIEF A - 18" square (46cm), 22" square (56cm)**

45"\* (115cm\*) - ¾ yd. (0.7m)

**APRON B - 18"W x 10"H (46cm x 25.5cm)**

45"\* (115cm\*) - 1 yd. (1.0m)

**APRON C - 18"W x 10"H (46cm x 25.5cm)**

45"\* (115cm\*) - 1 yd. (1.0m)

**CONTRAST - 45"\* (115cm\*) - ⅜ yd. (0.4m)****KNEEL PAD D - 10"W x 20"H (25.5cm x 51cm)**

45"\* (115cm\*) - ⅞ yd. (0.7m); 60"\* (150cm\*) - ½ yd. (0.5m)

**CONTRAST - 60"\* (150cm\*) - ½ yd. (0.5m)****PLANTING BAG E - Cut from Landscaping Fabric**

**Small:** 7"W x 7"H (18cm x 18cm)

**Medium:** 10"W x 8¼"H (25.5cm x 21cm)

**Large:** 12"W x 10"H (30cm x 25.5cm)

**GARDEN TOTE F - 10"W x 10"H x 10"D (25.5cm x 25.5cm x 25.5cm)**

45,60"\* (115,150cm\*) - ⅝ yd. (0.6m)

**CONTRAST - 45,60"\* (115,150cm\*) - ⅝ yd. (0.6m)****HAT G - XS - 21½" (54.5cm), S - 22¼" (56.5cm), M - 23" (58.5cm), L - 23¾" (60.5cm)**

45,60"\* (115,150cm\*) - 1 yd. (0.8m)

**CONTRAST - 60"\* (150cm\*) - ¼ yd. (0.3m)****INTERFACING - 20" (51cm) - 1⅞ yds. (1.1m)**

## CUTTING AND MARKING

- > **SHRINK FABRIC** if not labeled pre-shrunk. Press.
- > **CIRCLE LAYOUT** for View, Size, Fabric Width.
- > Use **WITH NAP** layout for fabrics with one-way designs, nap, pile or surface shading. Because most knits have surface shading, a with nap layout is used.
- > For **DOUBLE THICKNESS (WITH FOLD)**, fold fabric with right sides together.
- > \***DOUBLE THICKNESS (WITHOUT FOLD)**, for fabrics with nap, fold fabric crosswise, right sides together. Mark as shown. Cut along crosswise fold of fabric (A). Turn upper layer 180° so arrows go in same direction and place over lower layer, right sides together (B).
- > For **SINGLE THICKNESS**, place fabric right side up. (For Fur Pile fabrics, place pile side down.)

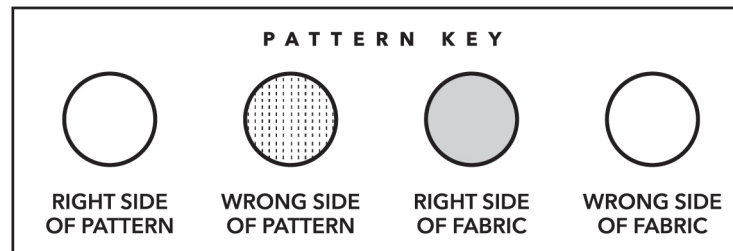
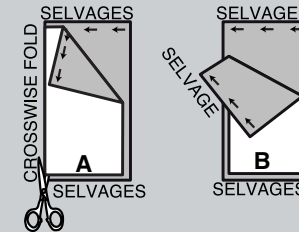

- > Before **CUTTING**, place all pieces on fabric according to layout. Pin.  
(Layouts show approximate position of pattern pieces; position may vary according to your pattern size.)
  - > ★ Cut other pieces first, allowing enough fabric to cut this piece. Open fabric. Cut piece on single layer of fabric with piece face up on right side of fabric.
  - > Cut accurately, cutting notches outward.
  - > Before removing pattern, **TRANSFER MARKINGS** and lines of construction to **WRONG SIDE** of fabric, using Pin and Chalk Pencil method or Tracing Paper and Dressmaker Wheel. Markings needed on right side of fabric should be thread traced.
- NOTE:** Broken-line boxes (a! b! c!) in layouts represent pieces cut by measurements provided.
- > Prewash your fabric using a method that's suitable for the fabric type.
  - > Fold fabric with right sides together, matching **SELVAGES**.
  - > Pin your pattern pieces to the fabric as shown below and cut them out using a sharp pair of dressmaker's shears.



**CUTTING LAYOUTS**

**KERCHIEF A**

use piece: 1

45" (115 cm)  
with nap  
all sizes



**APRON B**

use pieces: 2,3

45" (115 cm)  
with nap  
all sizes

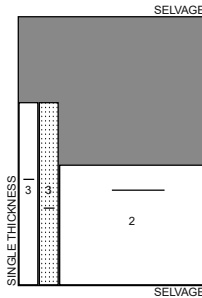

**APRON C**

use pieces: 2,3

45" (115 cm)  
with nap  
all sizes

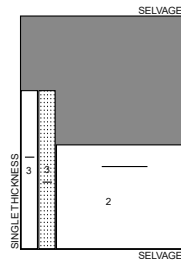

**CONTRAST C**

use pieces: 4,5

45" (115 cm)  
with nap  
all sizes

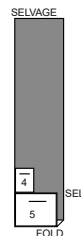

**KNEEL PAD D**

use pieces: 2,3

45" (115 cm)  
with nap  
all sizes

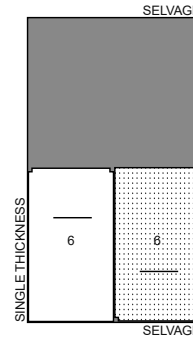

60" (150 cm)  
with nap  
all sizes

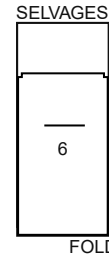

**CONTRAST D**

use piece: 7

60" (150 cm)  
with nap  
all sizes

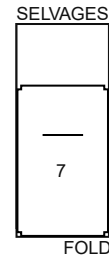

**PLANTING BAG E** - See Sewing Directions  
for cutting instructions.

**GARDEN TOTE F**

use piece: 11

45",60" (115,150 cm)  
with nap  
all sizes

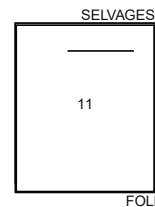

**CONTRAST F**

use piece: 12

45",60" (115,150 cm)  
with nap  
all sizes

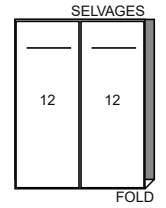

**HAT G**

use pieces: 13,14,16,17,18

45",60" (115,150 cm)  
with nap  
all sizes

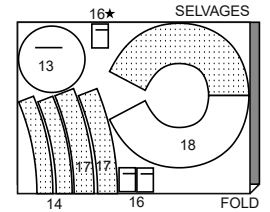

**CONTRAST G**

use piece: 15

60" (150 cm)  
with nap  
all sizes

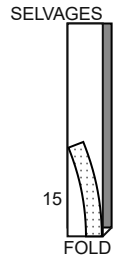

**INTERFACING G**

use piece: 18

20" (51 cm)  
with nap  
all sizes

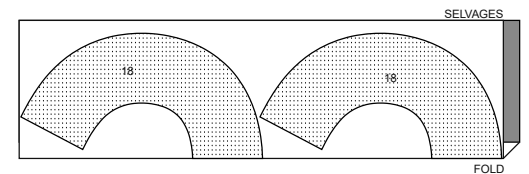

PATTERN PIECES WILL BE IDENTIFIED BY NUMBERS THE FIRST TIME THEY ARE USED.

### SEWING INFORMATION

**5/8" (1.5cm) SEAM ALLOWANCES ARE INCLUDED,**  
(unless otherwise indicated)

#### ILLUSTRATION SHADING KEY

Right Side	Wrong Side	Interfacing	Lining	Underlining

Pin or baste seams, right side together, matching notches. Fit garment before stitching major seams.

Press seam allowances flat; then open unless otherwise stated. Clip where necessary so they lie flat.

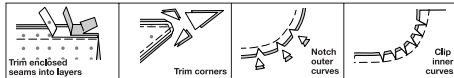

### GLOSSARY

Sewing terms appearing in **BOLD TYPE** in Sewing Instructions are explained below.

**FRENCH SEAM** -To make French seam, stitch first seam on **OUTSIDE**, a scant 1/4" (6mm) from seam line; trim close to stitching. Turn to **INSIDE** and stitch through seam allowance, encasing first seam.

**NARROW HEM** - Press under 1/2" (1cm) where indicated. To form hem, tuck under raw edge to meet crease; press. Stitch hem close to inner pressed edge.

## SEWING DIRECTIONS

**NOTE:** 1/2" (1.3cm) seam allowances are included.

### KERCHIEF A

**1. NARROW HEM** outer edges of kerchief (1), mitering corners as shown.

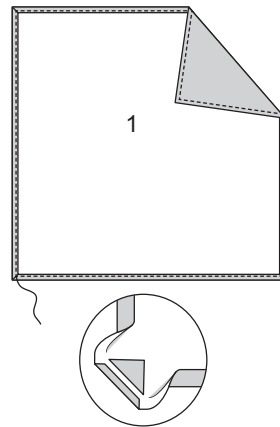

### Apron B, C

**2.** Fold tie end (3) in half, lengthwise along foldline, with **RIGHT** sides together, matching small dots. Stitch, leaving end with dots open. Trim seams. Trim corners.

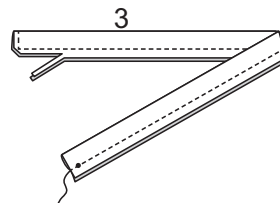

**3.** Turn tie end **RIGHT** side out; press. Top-stitch close to finished edges. On **OUTSIDE**, pin tie ends to apron (2), matching small and large dots, having raw edges even. Baste. **NARROW HEM** end of apron with small dots. Press under 1/2" (1.3cm) on remaining end, as shown.

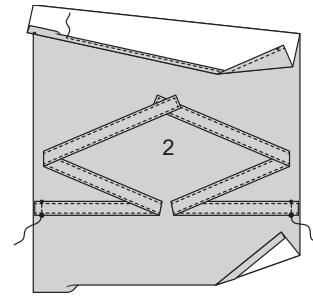

**4. APRON C-** With **RIGHT** sides together, fold tab (4) along fold line, matching small dots and having raw edges even. Stitch, leaving an opening in long edge for turning. Trim seams. Trim corners.



**5.** Turn tab **RIGHT** side out; press. Top-stitch close to finished edges, being careful to catch pressed edges of opening into stitching.



**6.** Stitch the two pocket (5) sections together, leaving an opening in lower edge for turning. Trim seams. Trim corners.

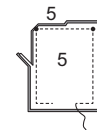

**7.** Turn pocket **RIGHT** side out; press, pressing under opening edges. Top-stitch pocket 1/4" (6mm) from upper edge. On **OUTSIDE**, pin tab and pocket to apron, matching large and small dots. Stitch across ends of tab, stitching over previous top-stitching. Stitch pocket close to side and lower edges.

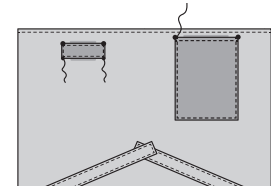

### Continue as Follows for Apron B, C

**8.** With **RIGHT** sides together, fold apron along fold lines, lapping lower end over upper end, matching small dots and having raw edges even. Stitch side edges.

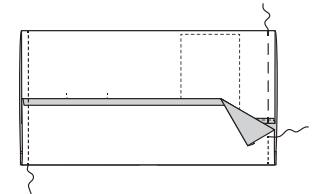

**9.** Turn apron **RIGHT** side out; press, pressing ties out. On **INSIDE**, stitch pressed edge of apron in place, pulling front pocket out of the way. Top-stitch outer edge of apron close to finished edges. Stitch front pocket along stitching line through all thicknesses.

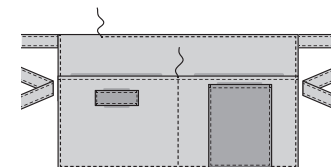
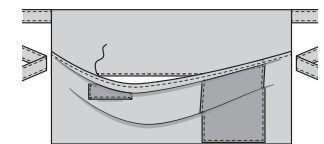

## KNEEL PAD D

**TIP:** We recommend using a non-stick presser foot or roller foot when stitching vinyl.

**1.** Separate hook and loop tape. On **WRONG** side, stitch each half of tape to upper edge of cover (6) sections, placing tape 1" (2.5cm) below raw edge. Stitch pad sections together along side and lower edges.

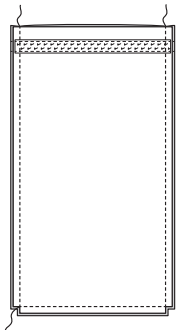
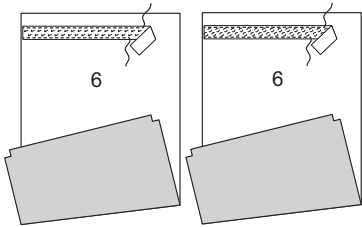

**2.** To form corners, bring side and lower seams together, having raw edges even. Stitch across corners between small dots.

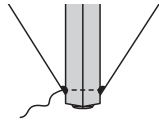

**3.** Turn cover **RIGHT** side out. **NARROW HEM** upper edge. Cut two pieces of webbing each 18" (45.4cm) long for handles. Press under 1/2" (1.3cm) on ends of handles. On **OUTSIDE**, pin handles to front and back of cover along placement lines. Stitch across pressed ends side edges and close to upper edge of pad.

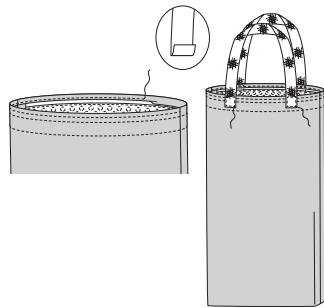

**4.** Stitch pad (7) sections along side and ends, leaving an opening between large dots to insert foam.

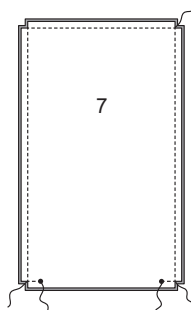

**5.** Make corners in pad same as for cover, see step 2. Turn pad **RIGHT** side out. Insert foam through opening. Slip-stitch opening closed. Insert pad into cover when finished.

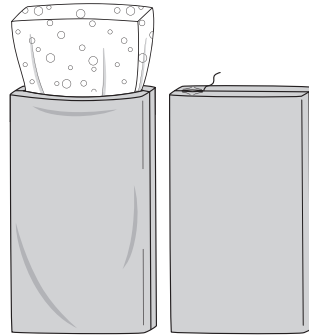

## PLANTING BAG E

**NOTE:** You have cut four bag sections from landscape fabric. Two sections will be referred to as fronts and two will be referred to as backs.

**1.** Stitch two planting bag (8 or 9 or 10) sections along upper edge for bag front.

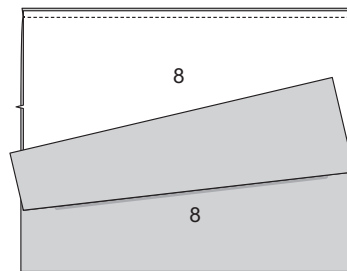

**2.** Turn front **RIGHT** side out; press. Baste raw edges together. Fold upper edge to **OUTSIDE** along fold line, forming a band. Stitch close to upper and lower edges of band. Prepare bag back with remaining sections in same manner.

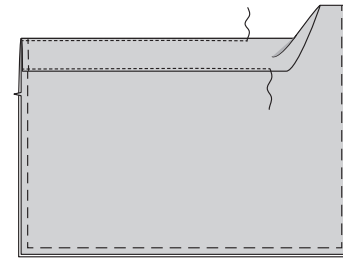

**3.** Stitch bag front to back along side edges in **FRENCH SEAMS**.

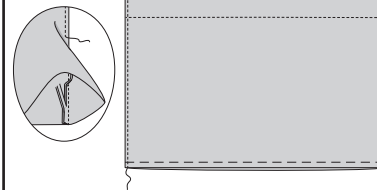

**4.** To stitch lower edge of bag, bring side seams together, having raw edges even. Stitch lower edge between small dots.

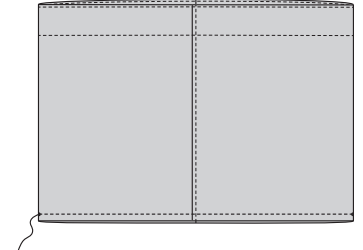

**5.** To form corners of bag, fold along fold lines, matching large dots. Stitch across point along stitching lines. Tack points together on **INSIDE** when finished.

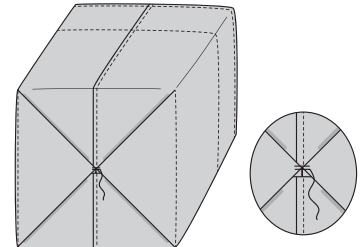
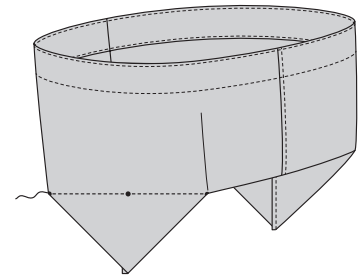

**6.** Turn bag RIGHT side out. Cut two pieces of webbing for handles as follows:  
 FOR LARGE BAG -22" (56cm)  
 FOR MEDIUM BAG -20" (51cm)  
 FOR SMALL BAG -18" (45.5cm)  
 Press under 1/2" (1.3cm) on ends of handles. On OUTSIDE, pin handles to upper edge of bag along placement lines. Stitch across pressed ends, side edges and close to upper edge of bag, stitching diagonally across webbing forming an X.

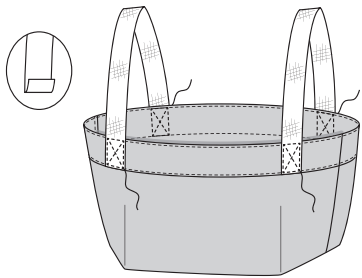

**2.** Cut two pieces of webbing for handles each 22" (56cm) long. Press under 1/2" (1.3cm) on ends of handles. On OUTSIDE, pin handles to upper edge of bag along placement lines. Stitch across pressed ends, close to side edges and across handle at upper edge of bag.

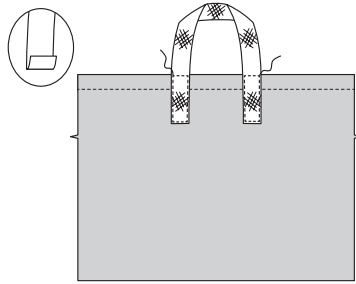

**3.** Make two pockets as follows: With RIGHT sides together, stitch two pocket (12) sections, leaving ends open.

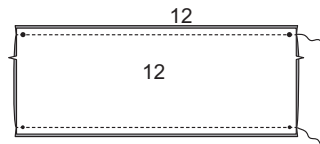

**4.** Turn pocket RIGHT side out; press. Top-stitch pocket close to upper edge. On OUTSIDE, pin pocket to prepared bag section along placement line and matching dots. Stitch pocket in place close to lower edge and along stitching lines. Baste raw edges together.

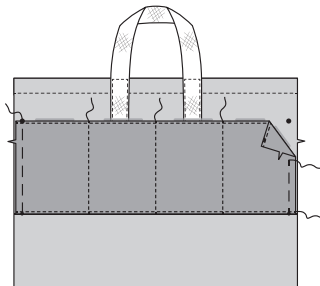

**5.** Stitch bag front to back along side edges in **FRENCH SEAMS**.

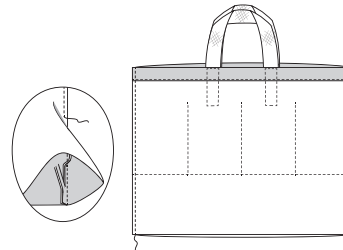

**6.** To stitch lower edge of bag, bring side seams together, having raw edges even. Stitch lower edge between small dots.

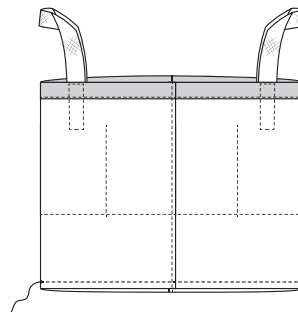

**7.** To form corners of bag, fold along fold lines, matching large dots. Stitch across point along stitching lines. Tack points together on INSIDE when finished.

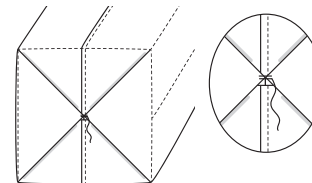
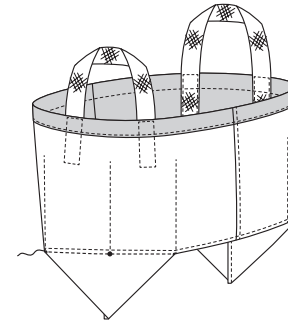

**8.** Turn bag RIGHT side out. Fold bag along fold lines on front and back. Stitch 1/4" (6mm) from fold, being careful not catch upper edge of pocket into stitching.

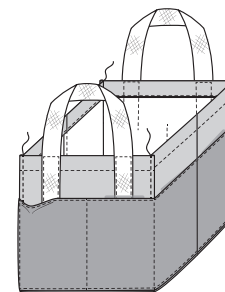

## HAT G

**1.** Make five tabs as follows: Fold tab (16) in half, lengthwise, with RIGHT sides together and having raw edges even. Stitch notched edge.

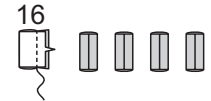

**2.** Turn tab RIGHT side out, bringing seam to center; press. Stitch center back seam of middle crown (15). On OUTSIDE, pin four tabs to middle crown along placement lines, matching small dots. Center remaining tab over center back seam, having raw edges even. Stitch tabs in place close to side edges.

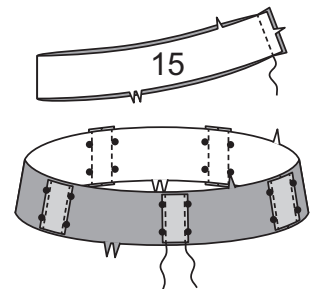

## GARDEN TOTE F

**1.** Prepare bag sections as follows: Press under 1/2" (1.3cm) on upper edge of bag (11). Turn upper edge to INSIDE along fold line. Press. Stitch pressed edge in place.

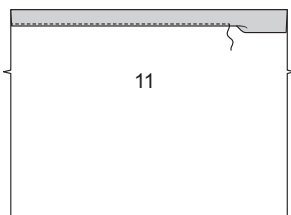

**3.** Stitch center back seams of upper crown (14) and lower crown (17) sections. With RIGHT sides together, stitch crowns to upper and lower edges of middle crown, matching centers and notches. Press seams away from middle crown. Machine-stitch 1/2" (1.3cm) from upper edge of crown.

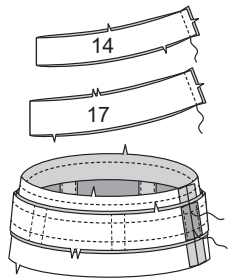

**4.** With WRONG sides together, baste top (13) sections, having raw edges even.

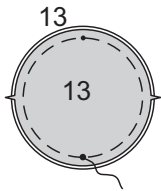

**5.** With RIGHT sides together, pin upper edge of crown to top, matching centers and clipping crown to stitching as necessary. Baste.

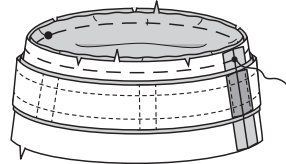

**6.** Stitch center back seam of upper crown facing. Machine-stitch 1/2" (1.3cm) from upper edge. Press under 1/2" (1.3cm) on lower edge; trim to 1/4" (6mm). With RIGHT sides together, pin upper crown facing to top facing, matching centers and clipping crown facing to stitching as necessary. Stitch through all thicknesses. Trim seam. Press crown facing up.

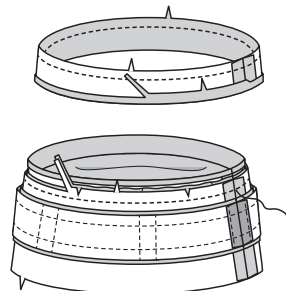

**7.** Press crown facing away from top. Slip-stitch pressed edge over seam.

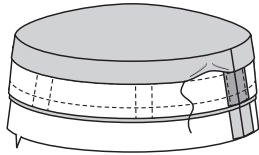

**8.** Pin interfacing to both brim (18) sections, having raw edges even. Baste raw edges together.

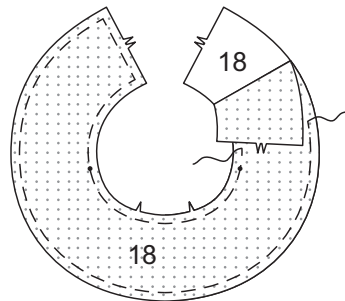

**9.** Stitch center back seam of brim. With RIGHT sides together, stitch outer edges of brim, matching centers and having raw edges even. Trim seam.

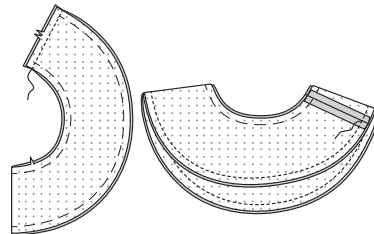

**10.** Turn brim RIGHT side out; press. Baste raw edges together. Top-stitch brim with seven rows of stitching, spacing each row 1/2" (1.3cm) apart. Pin ends of cord to inner edge of brim, placing ends at small dots. Baste. (This is the underside of the brim.)

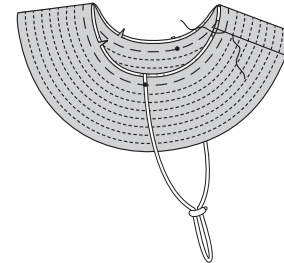

**11.** On OUTSIDE, pin brim (underside facing up) to lower edge of crown, matching centers and clipping inner edge of brim to basting as necessary. Baste.

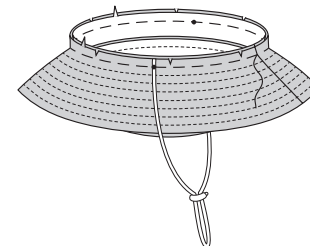

**12.** Stitch center back seam of lower crown facing. Press under 1/2" (1.3cm) on double notched edge; trim to 1/4" (6mm). With RIGHT sides together, pin facing to crown (over brim), matching centers and having raw edges even. Stitch through all thicknesses. Trim seam.

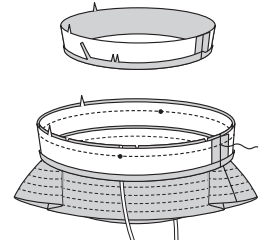

**13.** Turn facing to INSIDE; press, pressing brim down. Slip-stitch pressed edge of facing over seam.

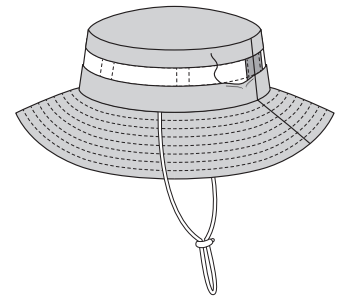

**14.** On OUTSIDE, top-stitch lower crown 1/4" (6mm) from seams. Apply snaps to brim and lower crown at small dots, following manufacturer's directions. Insert cord through cord stop when finished.

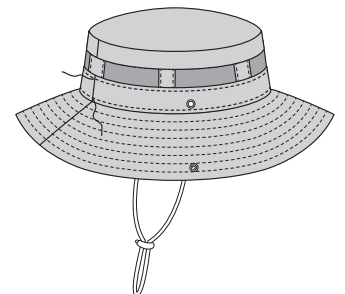



# Congrats!

You've completed your sewing adventure!

---

**SHARE  
YOUR** look!



Post your pattern and tag us at  
@MCCALLPATTERNCOMPANY and use #mccallpatterns  
for a chance to be featured on our social media!

Look for more McCall's PDF patterns at **McCallPattern.com**

 1-800-255-2762

© 2022 IG Design Group Americas, Inc. | All Rights Reserved  
Sold for individual home use only and not for commercial or manufacturing purposes.